

ANSI/AWS D14.1-85
An American National Standard

**Specification for
Welding of Industrial and
Mill Cranes and Other Material
Handling Equipment**

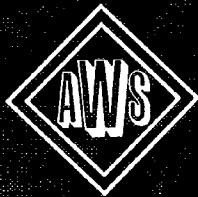

AMERICAN WELDING SOCIETY, INC.

Key Words — Cranes, Industrial Cranes, Material Handling Equipment, Mill Cranes, Specification.

ANSI/AWS D14.1-85
An American National Standard

Approved by
American National Standards Institute
July 29, 1982

Specification for
Welding of Industrial and Mill Cranes
and Other Material Handling Equipment

Supersedes
AWS D14.1-70

Issued 1970; Revised 1982

Prepared by
AWS Committee on Machinery and Equipment

Under the Direction of
AWS Technical Activities Committee

Approved by
AWS Board of Directors, April 29, 1982

Abstract

Overhead cranes and material handling equipment that utilize plate girders and other welded plate structures rather than the rolled beams normally used in fabricating steel for bridges and building are described.

The equipment covered by this specification also includes rotating equipment and movable components which can induce vibration and moving loads to the structure. These conditions and the associated fully reversible loading result in large numbers of load cycles in a relatively short period and local bending stresses of significant levels.

The above items have significant effects on the selection of base and filler metals, weld selection and joint design.

A qualification procedure for welding operators engaged in long run operations involving closely controlled procedures and welding conditions and repetitive welds based on results of welds produced under the specific existing conditions is also described.

AMERICAN WELDING SOCIETY
550 N.W. LeJeune Road, P.O. Box 351040, Miami, FL 33135

Policy Statement on Use of AWS Standards

All American Welding Society standards (codes, specifications, recommended practices, methods, etc.) are voluntary consensus standards that have been developed in accordance with the American National Standards Institute's rules for development and approval of American National Standards. When AWS standards are either incorporated in, or made part of documents that are incorporated in federal, state, or other governmental bodies' laws or regulations, their provisions carry the full legal authority of the statute. In such case, changes to AWS standards must be approved by the governmental body having statutory jurisdiction before they can become part of law and regulations. In all other cases, these standards carry the full legal authority of the contract or other invoking document that implements the use of AWS standards. Where this contractual situation prevails, changes or deviations to specific requirements in an AWS standard must be by agreement between the contracting parties and, where applicable, any governmental agencies involved.

International Standard Book Number: 0-87171-255-5

American Welding Society, 550 N.W. LeJeune Road, P.O. Box 351040, Miami, FL 33135

© 1985 by American Welding Society. All rights reserved
Printed in the United States of America
89 88 87 86 85 5 4 3 2 1

Note: By publication of this standard the American Welding Society does not insure anyone utilizing the standard against liability arising from the use of such standard. A publication of a standard by the American Welding Society does not carry with it any right to make, use, or sell any patented items. Each prospective user should make an independent investigation.

This standard is subject to revision at any time by the responsible technical committee. It must be reviewed every five years and if not revised, it must be either reapproved or withdrawn. Comments (recommendations, additions, or deletions) and any pertinent data which may be of use in improving this standard are requested and should be addressed to AWS Headquarters. Such comments will receive careful considerations by the responsible technical committee and you will be informed of the committee's response. Guests are invited to attend all meetings of AWS committees to express their comments verbally. Procedure for appeal of an adverse decision concerning your comments are provided in the Rules of Operation for AWS Technical Committees. A copy of these Rules can be obtained from the American Welding Society, 550 N.W. LeJeune Road, P.O. Box 351040, Miami, FL 33135.

Contents

<i>List of Illustrations</i>	vii
<i>List of Tables</i>	ix
<i>Personnel</i>	xi
<i>Foreword</i>	xiii
<i>Scope</i>	1
1. <i>General Provisions</i>	1
1.1 Acceptance.....	1
1.2 Definitions.....	1
1.3 Welding.....	2
1.4 Mechanical Testing of Welds.....	2
1.5 Filler Metal Specification.....	2
1.6 Safety Precautions.....	2
1.7 References.....	2
2. <i>Base Metals</i>	2
2.1 Structural Steel and Nonferrous Metals.....	2
2.2 Proprietary Base Metals.....	2
2.3 Weldability.....	2
2.4 Quenched and Tempered Steels.....	2
2.5 Nonferrous Metals.....	2
3. <i>Allowable Stresses</i>	3
3.1 General.....	3
3.2 Fatigue.....	4
4. <i>Weld Joint Design</i>	9
4.1 General Requirements.....	9
4.2 Groove Welds.....	9
4.3 Intermittent Groove Welds.....	9
4.4 Fillet Welds.....	9
4.5 Intermittent Fillet Welds.....	9
4.6 Staggered Intermittent Fillet Welds.....	11
4.7 Plug and Slot Welds.....	11
4.8 Suggested Classification of Welded Joints.....	12
4.9 Weld Joint Categories.....	12
4.10 Joint Qualification.....	12
4.11 Transition of Thicknesses or Widths at Butt Joints.....	12
4.12 Prequalified Extension Bars, Runoff Plates, and Backing Materials.....	40
4.13 Dimensional Tolerances.....	40
5. <i>Workmanship</i>	40
5.1 General.....	40
5.2 Preparation of the Base Metal.....	41
5.3 Visual Inspection and Repair of Plates and Wrought Steel Products.....	42
5.4 Assembly.....	43
5.5 Control of Distortion and Shrinkage Stresses.....	43
5.6 Stress Relief.....	43
5.7 Vibratory Conditioning.....	43
5.8 Studs.....	43

6. Processes and Filler Metals.....	45
6.1 General.....	45
6.2 Shielded Metal Arc Welding.....	48
6.3 Submerged Arc Welding.....	48
6.4 Gas Metal Arc and Flux Cored Arc Welding.....	50
6.5 Stud Welding.....	51
6.6 Electroslag and Electrogas Welding.....	51
7. Qualification.....	53
Part A, General Requirements.....	53
7.1 Approved Procedures.....	53
7.2 Other Procedures.....	53
7.3 Welders, Welding Operators, and Tack Welders.....	53
7.4 Qualification Responsibility.....	53
Part B, Procedure Qualification.....	53
7.5 Limitation of Variables.....	53
7.6 Types of Tests and Purposes.....	58
7.7 Base Metal.....	58
7.8 Position of Test Welds.....	58
7.9 Joint Welding Procedure.....	59
7.10 Test Specimens.....	59
7.11 Method of Testing Specimens.....	68
7.12 Test Results Required.....	70
7.13 Records.....	71
7.14 Retests.....	71
Part C, Performance Qualification.....	72
7.15 General.....	72
7.16 Limitations.....	72
7.17 Qualification Tests Required.....	72
7.18 Groove Weld Plate Qualification Test for Plate of Unlimited Thickness.....	75
7.19 Groove Weld Plate Qualification Test for Plate of Limited Thickness.....	75
7.20 Groove Weld Qualification Test for Butt Joints in Pipe or Tubing.....	77
7.21 Groove Weld Qualification Test for T-, Y-, and K-Connections on Pipe or Tubing.....	77
7.22 Fillet Weld Qualification Test.....	77
7.23 Position of Test Welds.....	77
7.24 Base Metal.....	79
7.25 Joint Welding Procedures.....	80
7.26 Test Specimens.....	80
7.27 Method of Testing Specimens.....	81
7.28 Test Results Required.....	84
7.29 Retests.....	84
7.30 Period of Effectiveness.....	84
7.31 Records.....	84
7.32 Workmanship Qualification.....	84

<i>Part D, Welding Operator Qualification</i>	86
7.33 <i>General</i>	86
7.34 <i>Limitations</i>	86
7.35 <i>Required Tests</i>	86
7.36 <i>Base Metal</i>	88
7.37 <i>Joint Welding Procedure</i>	88
7.38 <i>Test Specimens</i>	88
7.39 <i>Method of Testing Specimens</i>	90
7.40 <i>Test Results Required</i>	90
7.41 <i>Retests</i>	90
7.42 <i>Period of Effectiveness</i>	90
7.43 <i>Records</i>	90
<i>Part E, Qualification of Tack Welders</i>	90
7.44 <i>General</i>	90
7.45 <i>Limitations</i>	90
7.46 <i>Qualification Tests Required</i>	91
7.47 <i>Base Metal</i>	91
7.48 <i>Test Specimens</i>	91
7.49 <i>Method of Testing</i>	91
7.50 <i>Test Results Required</i>	91
7.51 <i>Retests</i>	91
7.52 <i>Period of Effectiveness</i>	91
7.53 <i>Records</i>	91
8. Weld Quality and Inspection	91
8.1 <i>General</i>	91
8.2 <i>Purchaser's Representative</i>	92
8.3 <i>Inspection of Welding Procedure Qualification</i>	92
8.4 <i>Inspection of Welder, Tack Welder, and Welding Operator Qualification</i>	92
8.5 <i>Inspection of Work and Records</i>	92
8.6 <i>Visual Examination</i>	92
8.7 <i>Welding Profiles</i>	93
8.8 <i>Nondestructive Examination</i>	93
8.9 <i>Radiographic Examination of Welds</i>	93
8.10 <i>Radiographic Procedure</i>	95
8.11 <i>Acceptability of Radiographed Welds</i>	95
8.12 <i>Examination, Report, and Disposition of Radiographs</i>	95
8.13 <i>Ultrasonic Examination of Welds</i>	95
8.14 <i>Ultrasonic Testing Equipment and Calibration</i>	96
8.15 <i>Ultrasonic Testing Procedure, Acceptance Criteria, and Reports</i>	100
8.16 <i>Magnetic Particle Examination of Welds</i>	102
8.17 <i>Liquid Penetrant Examination of Welds</i>	103
8.18 <i>Inspection of Studs</i>	104
9. Field Weld Repair and Modification	105
9.1 <i>General</i>	105
9.2 <i>Field Repair—Manufacturer's Responsibility</i>	105
9.3 <i>Field Repair—Purchaser's Responsibility</i>	105

10. *Repair and Correction of Discontinuities*..... 105

 10.1 *Weld Repairs*..... 105

 10.2 *Base Metal Repairs*..... 107

 10.3 *Removal of Defective Area*..... 107

 10.4 *Distortion and Camber*..... 107

 10.5 *Correction of Improperly Fitted and Welded Members*..... 107

 10.6 *Repair of Studs*..... 107

Appendix A — Suggested Forms..... 109

Appendix B — Commonly Used Metric Conversions..... 119

Appendix C — Examples of Weld Quality Requirements..... 121

List of Illustrations

Figure 1	Examples of various fatigue categories.....	8
Figure 2	Fillet and combined weld dimension.....	10
Figure 3	Size and effective throat of fillet and combination groove-fillet welds.....	11
Figure 4	Staggered intermittent fillet weld.....	12
Figure 5	Classification of welded joints.....	13
Figure 6	Prequalified complete-joint-penetration groove welded joints.....	15-29
Figure 7	Prequalified partial-joint-penetration groove welded joints.....	30-38
Figure 8	Transition butt joints in parts of unequal thickness.....	39
Figure 9	Transition of width at butt joints of parts having unequal width.....	40
Figure 10	Edge discontinuities in cut plate.....	43
Figure 11	Unacceptable submerged arc weld pass where the depth and width exceed the face width.....	49
Figure 12A	Transverse fillet weld shearing specimen.....	54
Figure 12B	Longitudinal fillet weld shear specimen.....	55
Figure 13	Positions of test plates for groove welds.....	59
Figure 14	Positions of test pipe or tubing for groove welds.....	60
Figure 15	Positions of test plates for fillet welds.....	61
Figure 16A	Location of test specimens on welded test pipe 2 in. or 3 in. in diameter.....	62
Figure 16B	Location of test specimens on welded test pipe 6 in. or 8 in. in diameter.....	62
Figure 16C	Location of test specimens on welded test plate-electroslag and electrogas welding-procedure qualification.....	64
Figure 16D	Location of test specimens on welded test plate over 3/8 in. thick-procedure qualification.....	65
Figure 16E	Location of test specimens on welded test plate 3/8 in. thick-procedure qualification.....	66
Figure 17A	Reduced-section tension specimens.....	67
Figure 17B	All-weld-metal tension specimens.....	68
Figure 17C	Face-and root-bend specimens.....	69
Figure 17D	Side-bend specimens.....	70
Figure 18	Fillet weld soundness test for procedure qualification.....	71
Figure 19A	Test plate for unlimited thickness-welder qualification.....	75
Figure 19B	Optional test plate for unlimited thickness-horizontal position-welder qualification.....	76
Figure 20A	Test plate for limited thickness-welder qualification.....	76
Figure 20B	Optional test plate for limited thickness horizontal position-welder qualification.....	77
Figure 21A	Plate and pipe butt joint-welder qualification-without backing.....	78
Figure 21B	Pipe test butt joint-welder qualification-with backing.....	78
Figure 22	Test joint for T-, K-, and Y-connections on pipe or square or rectangular tubing-welder qualification.....	78
Figure 23	Fillet weld break and macroetch test plate-welder qualification-Option 1.....	79
Figure 24	Fillet weld root bend test plate-welder qualification-Option 2.....	80
Figure 25	Location of test specimens on welded test pipe-welder qualification.....	81
Figure 26A	Guided-Bend Test Jig.....	82
Figure 26B	Alternate wraparound guided-bend test jig.....	83
Figure 26C	Alternate roller-equipped guided-bend test jig for bottom ejection of test specimen.....	83
Figure 27	Examples of workmanship samples.....	85
Figure 28	Test plate for unlimited thickness-welding operator qualification.....	86
Figure 29	Butt joint for electroslag and electrogas welding-operator qualification.....	87
Figure 30	Fillet weld break and macroetch test plate-Option 1-welding operator qualification.....	88
Figure 31	Fillet weld root-bend test plate-Option 2-welding operator qualification.....	89
Figure 32	Fillet weld break specimen-tack welder qualification.....	91
Figure 33	Method of fracturing specimen-tack welder qualification.....	91
Figure 34	Acceptable and unacceptable weld profiles.....	91

Figure 35	Weld quality requirements for discontinuities occurring in tension welds (limitation of porosity and fusion-type discontinuities).....	96
Figure 36A	RC-Resolution reference block.....	97
Figure 36B	Transducer positions (typical).....	98
Figure 37	Plan view of welded plate.....	103
Figure 38	Torque testing arrangement and table of testing torques.....	106

List of Tables

Table 1	Weldability classification of qualified steels.....	3
Table 2	Allowable stresses in welds.....	4
Table 3A	Allowable range of stress ksi(MPa).....	5
Table 3B	Fatigue stress provisions — tension or reversal stresses.....	6
Table 4	Minimum effective throat for partial-joint-penetration groove welds.....	9
Table 5	Minimum fillet weld size.....	10
Table 6	Limits on acceptability and repair of edge discontinuities in plate.....	42
Table 7	Tolerances for groove weld joint preparations for arc welding.....	44
Table 8	Matching filler metal requirements for prequalified complete-joint-penetration groove welds.....	45
Table 9	Minimum preheat and interpass temperature.....	46
Table 10	Impact strength requirements for electrogas and electroslag welds.....	52
Table 11	All-weld-metal tension test requirements for electrogas and electroslag welds.....	52
Table 12	Number and type of test specimens and range of thickness qualified— procedure qualification; complete-joint-penetration groove welds.....	62
Table 13	Acceptable reinforcement on groove welds in pipe and tubing.....	72
Table 14	Grouping of shielded metal arc welding electrodes for performance qualification.....	72
Table 15	Welder qualification-type and position limitations.....	73
Table 16	Number and type of specimens and range of thickness qualified — welder and welder operator qualification.....	74
Table 17	Testing angle.....	101
Table 18	Ultrasonic acceptance-rejection criteria.....	104

Personnel

AWS Committee on Machinery and Equipment

<i>S. Wismer, Chairman</i>	Nuclear Utility Construction Division of Underwater Construction Corporation
<i>W. B. Root, 1st Vice Chairman</i>	Bucyrus-Erie Company
<i>C. C. Brainard, 2nd Vice Chairman</i>	The Alliance Machine Company
<i>W. A. Dierschow, Secretary</i>	American Welding Society
<i>I. M. Barta*</i>	Consultant
<i>K. T. Bassett</i>	Danly Machine Corporation
<i>J. D. Brown</i>	Fiat-Allis Construction Machinery Division
<i>C. E. Childress</i>	Oak Ridge National Laboratory
<i>G. E. Cossaboom</i>	Gilbert-Commonwealth Associates
<i>J. B. Deam*</i>	National Machine Tool Builders Association
<i>S. M. El Soudani*</i>	Consultant
<i>W. Fildes</i>	Caterpillar Tractor Company
<i>J. G. Freeberg</i>	Aluminum Company of America
<i>E. H. Girard</i>	U.S. Nuclear Regulatory Commission
<i>R. T. Hemzacek</i>	Argonne National Laboratory
<i>B. R. Jamieson</i>	Consultant
<i>C. F. Koenig</i>	Consultant
<i>W. A. Maddox*</i>	Consultant
<i>R. M. Manning</i>	Harnischfeger Corporation
<i>D. C. Martinez</i>	DanMar Engineering
<i>A. R. Mellini</i>	WABCO Construction and Mining Equipment
<i>J. Mikulak</i>	Consultant
<i>H. W. Mishler</i>	Battelle Memorial Institute
<i>S. H. Moutoux</i>	Clark Equipment Company
<i>R. D. Myers**</i>	Harnischfeger Corporation
<i>P. J. Palzkill</i>	John Deere Company
<i>J. R. Stitt*</i>	Consultant
<i>W. H. Wooding</i>	Consultant

Subcommittee on Industrial and Mill Cranes

<i>C. C. Brainard, Chairman</i>	The Alliance Machine Company
<i>M. J. Kwashny, Vice Chairman</i>	Whiting Corporation
<i>G. Castleberry*</i>	Conco-Tellus, Incorporated
<i>J. V. Chvala</i>	Dresser Industries
<i>J. G. Freeberg</i>	Aluminum Company of America
<i>E. H. Girard</i>	U.S. Nuclear Regulatory Commission
<i>J. C. Goods, Jr.</i>	Kranco, Incorporated
<i>G. H. Jeffers</i>	Jeffers Engineering & Supply
<i>R. D. Myers**</i>	Harnischfeger Corporation
<i>P. E. Walters</i>	Jervis B. Webb Company

*Advisory Member

**Deceased

Foreword

This specification was prepared for the overhead crane and material handling industries to continue the advance of welding and to increase product reliability. This edition provides a more complete specification than the original D14.1-70, *Specification for Welding Industrial and Mill Cranes*, under the direction of the AWS Machinery and Equipment Committee.

Subcommittee D14a of the above committee was reconvened in March 1975 to review the existing Specification and commence the process of revising and updating it. At this time, under the guidance of the parent committee, it was decided that D14.1 should be an "all-inclusive" document with a format similar to D1.1. The work of rewriting continued through 1978, and the document was submitted to TAC and TC for approval in 1979. Due to outside commitments of the Chairman and his untimely death, approval was delayed until 1982. The AWS Publishing Staff recommended several editorial changes which were made. The document was finalized by Subcommittee D14a and approved by Committee D14 in October 1984. At that time, it was resubmitted to TAC and TC for reapproval and was ready for publication in mid-1985.

The participating committee, representing manufacturers, users, and government joined in the preparation of this document. It will provide all concerned, including the general public, with high quality, reliable products and an economical approach to production, consistent with the industry's capabilities.

The crane and materials handling industries adopted new welding processes and techniques as soon as they economically met existing design requirements. The continuing investigation and application of new methods and technology leads to greater confidence in the reproductibility of quality work by the welder and welding operator.

This specification will be reviewed periodically to assure its success in serving all parties concerned with its provisions. Revisions will be issued when warranted.

Comments or inquiries are welcome. They should be addressed to Secretary, AWS Machinery and Equipment Committee, American Welding Society, 550 N. W. LeJeune Road, P.O. Box 351040, Miami, FL 33135.

Specification for Welding of Industrial and Mill Cranes and Other Material Handling Equipment

Scope

This specification applies to the welding of all principal structural weldments and all primary welds used in the manufacture of cranes for industrial, mill, power house, and nuclear facilities. It also applies to other overhead material handling machinery and equipment that support and transport loads within the design rating, vertically or horizontally, during normal operations. It also applies, when agreed upon between the buyer and manufacturer, to loading caused by abnormal operations or environmental events, such as seismics. Secondary welds that will be subjected to stresses of less than 6000 psi (41.4 MPa)¹ need only meet the requirements of Section 5, Workmanship, and Section 8, Weld Quality and Inspection. The engineering drawings shall specify the joint detail, type, and size of weld. This specification is not intended for application to construction- or crawler-type cranes.

All provisions of this specification are equally applicable to the strengthening and repairing of existing overhead cranes and material handling equipment as described above.

1. General Provisions

The manufacturer's² adherence to this specification shall include responsibility for the following:

(1) Welding, as defined in Scope, in accordance with this specification

1. The primary units in this specification are U.S. customary units. Approximate conversions to SI are given in parentheses throughout the specification.

2. Manufacturer means the organization responsible for the performance of the work covered by this specification.

(2) Producing the welds designated on the drawings by appropriate welding symbols and notes containing sufficient detail to show joint preparations compatible with the designated welding processes

(3) Providing written welding procedures

(4) Recording results of all procedure and welder qualification tests

(5) Controlling the use of designated base metals and consumables

(6) Inspecting the welds to the requirements of this specification

1.1 Acceptance. Acceptance shall be as agreed upon between the manufacturer and the purchaser.

1.2 Definitions. The terms that follow are defined for the purposes of this specification. Other terms used in this specification are defined in AWS A3.0, *Standard Welding Terms and Definitions*, latest edition.

1.2.1 Principal Structural Weldments. Those weldments that carry the main working loads during normal operations.

1.2.2 Primary Welds. Welds that should they fail, would result in (1) a carried load being dropped in excess of 4 in. (101.6 mm) or (2) an increase of stresses beyond the design limits in other welds in a principal structural weldment, as shown in Section 3. Any welds subject to only compressive stresses are not considered primary.

1.2.3 Secondary Welds. Secondary welds are those welds not covered by the requirements of 1.2.2 and must be noted as such on the drawings. They must carry compressive stress only or be subjected to a stress of less than 6000 psi (41.1 MPa).

Secondary welds only need meet the requirements of Section 5, Workmanship, and Section 8, Weld Quality and Inspection.

2/SPECIFICATION FOR WELDING OF INDUSTRIAL & MILL CRANES

1.2.4 Tensile Strength of The Weld Metal. The minimum tensile strength specified for the filler metal classification as published in the applicable filler metal specification.

1.2.5 Yield Strength of a Base Metal. The minimum specified yield strength as published in the applicable base metal specification. When the base metal specification does not establish a minimum yield strength for acceptance, the manufacturer shall establish and document the minimum yield strength for design purposes. The documentation may be in the form of references to published data or compilations of test data. In the establishment of minimum yield strengths for design purposes, due regard shall be made for size effects, thermal or mechanical treatments, and the effect of the welding process on the base material in the heat-affected zone.

1.2.6 Tack Welder. An individual whose primary function is to make any small assembly tack welds that are needed to hold the structural components of a weldment together securely until the welding operation is accomplished.

1.3 Welding Symbols. Welding symbols used on shop drawings shall be those shown in the latest edition of AWS A2.4, *Symbols for Welding and Nondestructive Testing*. Special requirements shall be fully explained by added notes or details.

1.4 Mechanical Testing of Welds. Methods used in the mechanical testing of welds shall be those described in the latest edition of AWS B4.0, *Standard Methods for Mechanical Testing of Welds*.

1.5 Filler Metal Specifications. All welding consumables must meet the requirements of the applicable AWS filler metal specifications, except for specific requirements of this specification.

1.6 Safety Precautions. Safety precautions shall conform to the latest edition of ANSI Publication Z49.1, *Safety in Welding and Cutting*, published by the American Welding Society.

1.7 References. Where specified, the following standards apply and become a part of this specification:

ANSI Z49.1 ³	ASTM E317	AWS A5.5	AWS A5.26
ASTM E23 ⁴	ASTM E500	AWS A5.17	AWS A5.28
ASTM E94	ASTM E709	AWS A5.18	AWS A5.29
ASTM E142	AWS A2.4 ⁵	AWS A5.20	AWS B4.0
ASTM E164	AWS A3.0	AWS A4.23	AWS QC1
ASTM E165	AWS A5.1	AWS A5.25	

2. Base Metals

2.1 Structural Steel and Nonferrous Metals. All ferrous and nonferrous metals, structural steel, steel castings, forgings, and any other metals used in the fabrication by welding of all components for overhead material handling machinery and equipment must be identified by a specification. Common industry-wide specifications such as ASTM, AISI⁶, SAE⁷, and AFS⁸, or written proprietary specifications developed by an individual equipment manufacturer may be used.

2.2 Proprietary Base Metals. The weldability of and the procedure for welding (1) base metals covered by a specific equipment manufacturer's proprietary specification (2) steels not listed in Table 1, or (3) base metals not covered by accepted national specifications shall be established by qualification, except as provided for in 2.3.

2.3 Weldability. Steel base metals listed in Table 1 shall be considered weldable without separate qualification. Combinations of any of these steel base metals may be welded together without qualification. The steels listed in Table 1 are classified into groups according to the degree of difficulty encountered during welding related to chemical composition, rolling condition, or heat treatment. Steels in the higher classifications require greater precautions during welding, such as preheat, limited heat input, or other precautions to insure sound weldments. When welding combinations of these steels, precautions related to the steel with the higher classification number should be observed.

2.4 Quenched-and-Tempered Steels. Quenched-and-tempered steels may be used where design and other factors permit or require them. Their use shall be compatible with their mechanical properties and the design requirements as documented by the equipment manufacturer. Documentation may be in either of two forms:

- (1) An acceptable service history proving reliability
- (2) Welding procedure development data establishing the expected service life of the steel according to accepted engineering criteria for the application

2.5 Nonferrous Metals. Nonferrous metals that meet the requirements of an accepted specification, as described in 2.1, may be used in the fabrication of components by

3. American National Standards Institute
4. American Society for Testing and Materials
5. American Welding Society
6. American Iron and Steel Institute
7. Society of Automotive Engineers
8. American Foundrymen's Association

welding. Proper documentation in the form of welding procedures and other experimental data shall be provided by the manufacturer using such metals.

Table 1
Weldability classification
of qualified steels

Weldability Classification ^a	Steel	
I	AISI/SAE	
	1005 1016	
	1006 1017	
	1008 1018	
	1010 1020	
	1012 1021	
	1013 1025	
	1015	
	ASTM	
	A27 Gr N-1, 60-30	
	II	ASTM
		A27 Gr 60-30, 65-35
		A36
		A53 Gr B
		A106 Gr A, B
A131 Gr A, B, D, E, CS, DS		
A139		
A284 Gr C thru 2 in. (51 mm), D thru 1 in. (25.4 mm)		
A381 Gr Y35		
A500 Gr A, B		
A501		
A515 G4 55 thru 8 in. (203 mm)		
A516		
A524		
A529		
A570 Gr		
A573		
A662 Gr A		
A709 Gr 36		
ABS^b		
Gr A, B, D, E, CS, DS		
API^c		
5L Gr B		
III	AISI/SAE	
	1030	
	ASTM	
	A27 Gr N-2, 70-36, 70-40	
	A106 Gr C	
A131 Gr AH32, DH32, EH 32, AH 36, DH 36, EH 36		

Table 1 (continued)

Weldability Classification ^a	Steel
	A284 Gr C thru 4 in. (102 mm), D thru 4 in. (102 mm)
	A441
	A500 Gr C
	A515 Gr 60 thru 2 in. (51 mm), 65 thru 2 in. (51 mm)
	A527 C1 1
	A572 Gr 42, 45, 50
	A588 4 in. and under
	A606 Gr 45, 50, 55
	A607 Gr 45, 50, 55
	A618 Gr II, III
	A633 Gr A, B, C, D
	A662 Gr B
	A709 Gr 50, 50W
	ABS^b
	Gr Ah, DH, EH
	API
	5L Gr B
	5 LX Gr 42
	ASTM
	A284 Gr C over 4 in. (102 mm), D over 4 in. (102 mm)
	A515 Gr 65, 70
	A537 C1 2
	A572 Gr 55, 60, 65
	A607 Gr 60, 65
	A633 Gr E
	ASTM
	A514
	A517
	A709 Gr 100, 100W

(a) Class I steels are the most weldable, and Class V steel the most difficult to weld of the steels listed.

(b) ABS — American Bureau of Shipping ordinary-strength hull structural steel.

(c) API — American Petroleum Institute.

3. Allowable Stresses

3.1 General. The allowable stresses for base metal and weld metal and the type of fatigue analysis to be used shall conform to the requirements of the design specifications, such as AISC, ASME, CMAA⁹, or MMA¹⁰. In the

9. Crane Manufacturers Association of America
10. Monorail Manufacturers Association

4/SPECIFICATION FOR WELDING OF INDUSTRIAL & MILL CRANES

absence of other requirements, the allowable stresses in the base metal and the weld metal shall conform to the following requirements.

3.1.1 Base Metal. Unless otherwise specified, the allowable tensile or compressive stress in the base metal shall be 50 percent of the yield strength, and the allowable shear stress in the base metal shall be 40 percent of the yield strength for members not controlled by buckling.

3.1.2 Weld Metal. Allowable stresses in the weld metal shall conform to Table 2.

3.2 Fatigue. The maximum stress in welded joints subject to repeated stress fluctuations or reversals shall not exceed (1) the basic allowable stress or (2) the allowable fatigue stress as defined in the design specifications indi-

cated in 3.1. In the absence of other requirements, fatigue loading shall be addressed as follows:

3.2.1 Members subject to repeated loading shall be designed so that the maximum stress does not exceed that allowed by 3.1, and the stress range does not exceed the value given in Table 3A for the applicable general condition and situation described in Table 3B. Examples of the various fatigue stress categories are shown in Fig. 1.

3.2.2 The stress range is the maximum stress minus the minimum stress. The minimum stress is considered negative if it is opposite in direction to the maximum stress. The nominal number of loading cycles shall be the number defined in the design specification for the duty cycle class or determined by the engineer for the duty cycle and life specified in the purchase contract.

Table 2
Allowable stresses in welds

Type of weld	Stress in weld		Allowable stress	Required weld strength level ^b
Complete joint penetration	Tension normal to the effective area ^a		Same as base metal.	Matching weld metal must be used.
	Compression normal to the effective area.		Same as base metal.	Weld metal with a strength level equal to or one classification (10 ksi) less than matching weld metal may be used.
	Tension or compression parallel to the axis of the weld.		Same as base metal.	
	Shear on the effective area.		0.27 nominal tensile strength of weld metal (ksi), except shear stress on base metal shall not exceed 0.36 yield strength of base metal.	
Partial joint	Compression normal to effective area.	Joint not designed to bear.	0.45 nominal tensile strength of weld metal (ksi), except stress on base metal shall not exceed 0.55 yield strength of base metal.	Weld metal with a strength level equal to or less than matching weld metal may be used.
		Joint designed to bear.	Same as base metal.	
	Tensile or compression parallel to the axis of the weld ^c		Same as base metal.	
	Shear parallel to axis of weld.		0.27 nominal tensile strength of weld metal (ksi), except shear stress on base metal shall not exceed 0.36 yield strength of base metal.	

(Continued)

Table 2 (continued)

Type of weld	Stress in weld	Allowable stress	Required weld strength level ^b
	Tension normal to effective area.	0.27 nominal tensile strength of weld metal (ksi), except tensile stress on base metal shall not exceed 0.55 yield strength of base metal.	Weld metal with a strength level equal to or less than matching weld metal may be used.
Fillet welds	Shear on effective area ^a	0.27 nominal tensile strength of weld metal (ksi), except shear stress on base metal shall not exceed 0.36 yield strength of base metal.	Weld metal with a strength level equal to or less than matching weld metal may be used.
	Tension or compression parallel to axis of weld ^c	Same as base metal.	
Plug and slot welds	Shear parallel to faying surfaces (on effective area)	0.27 nominal tensile strength of weld metal (ksi), except shear stress on base metal shall not exceed 0.36 yield strength of base metal.	Weld metal with a strength level equal to or less than matching weld metal may be used.

(a) For definition of effective area, see 4.2, 4.4, 4.7.

(b) For matching weld metal, see Table 8.

(c) Fillet welds and partial joint penetration groove welds joining the component elements of built-up members, such as flange-to-web connections, may be designed without regard to the tensile or compressive stress in these elements parallel to the axis of the welds.

Table 3A
Allowable range of stress, ksi (MPa)

Stress category	Nominal number of loading cycles ^a			
	10,000 to 20,000	100,000 to 500,000	500,000 to 2,000,000	Over 2,000,000
A	40 (276)	32 (221)	24 (166)	24 (166)
B	33 (228)	25 (172)	17 (117)	15 (103)
C	28 (193)	21 (145)	14 (96)	12 (83)
D	24 (166)	17 (117)	10 (69)	9 (62)
E	17 (117)	12 (83)	7 (48)	6 (41)
F	17 (117)	14 (96)	11 (76)	9 (62)

(a) For under 20,000 loading cycles, use the allowable stresses for static loads in accordance with Table 2.

6/SPECIFICATION FOR WELDING OF INDUSTRIAL & MILL CRANES

Table 3B
Fatigue stress provisions-tension or reversal stresses^(a)

General condition	Situation	Stress category	Example			
Plain material	Base metal with rolled or cleaned surfaces. oxygen-cut edges with ANSI smoothness of 1000 or less.	A	1, 2			
Built-up members	Base metal and weld metal in members without attachments, built-up plates or shapes connected by continuous complete or partial-joint-penetration groove welds or by continuous fillet welds parallel to the direction of applied stress.	B	3, 4, 5, 7			
	Calculated flexural stress at toe of transverse stiffener welds on girder webs or flanges.	C	6			
	Base metal at end or partial length welded cover plates having square or tapered ends, with or without welds across the ends.	E	7			
Groove welds	Base metal and weld metal at complete-joint-penetration groove welded splices of rolled and welded sections having similar profiles when welds are ground and weld soundness established by nondestructive testing.	B	8, 9			
	Base metal and weld metal in or adjacent to complete-joint-penetration groove welded splices at transitions in width or thickness, with welds ground to provide slopes no steeper than 1 to 2-1/2 and weld soundness established by nondestructive testing.	B	10, 11			
Groove welded	Base metal at details of any length attached by groove welds subjected to transverse or longitudinal loading, or both, when weld soundness is transverse to the direction of stress is established by nondestructive testing and the detail embodies a transition radius, R, with the weld termination ground when	Longitudinal loading	Example			
		Transverse loading				
		Materials having equal or unequal thickness sloped welds ground web connections	Materials having equal thickness, not ground; web connections excluded.	Materials having unequal thickness, not sloped or ground, including web connections.		
	(a) R > 24 in. (610 mm)	B	B	C	E	13
	(b) 24 in. (610 mm) > R > 6 in. (152 mm)	C	C	C	E	13
	(c) 6 in. (152 mm) > R > 2 in. (51 mm)	D	D	D	E	13
	(d) 2 in. (51 mm) > R > 0	E	E	E	E	12, 13

(a) Except as noted for fillet and stud welds.

(Continued)

Table 3B (continued)

General condition	Situation	Stress category	Example
Groove welds	Base metal and weld metal in or adjacent to complete-joint-penetration groove welded splices either not requiring transition or when required with transitions having slopes no greater than 1 to 2-1/2, and when in either case, reinforcement is not removed and weld soundness is established by nondestructive testing.	C	8, 9, 10, 11
Groove or fillet welded connections	Base metal at details attached by groove or fillet welds subject to longitudinal loading where the details embody a transition radius, R, less than 2 in. (51 mm) and when the detail length, L, parallel to the line of stress is		
	(a) < 2 in. (51 mm)	C	12, 14, 15, 16
	(b) 2 in. (51 mm) < L < 4 in. (102 mm)	D	12
	(c) L > 4 in. (102 mm)	E	12
Fillet welded connections	Base metal at details attached by fillet welds parallel to the direction of stress regardless of length when the detail embodies at transition radius, R, 2 in. (51 mm) or greater and with the weld termination ground.		
	(a) When R > 24 in. (610 mm)	B	13
	(b) When 24 in. (610 mm) > R > 6 in. (152 mm)	C	13
	(c) When 6 in. (152 mm) > R > 2 in. (51 mm)	D	13
Fillet welds	Shear stress on throat of fillet welds.	F	8a
	Base metal at intermittent welds attaching transverse stiffeners and stud-type shear connectors.	C	7.14
	Base metal at intermittent fillet welds attaching longitudinal stiffeners.	E	—
Stud welds	Shear stress on nominal shear area of stud-type shear connectors.	F	14
Plug and slot welds	Base metal adjacent to or connected by plug or slot welds.	E	—

Notes:

- Finished according to 8.7.
 - Either RT or UT to meet quality requirements of Section 8 for welds subject to tensile stress.
 - Sloped as required by 4.11.
 - Applicable only to complete-joint-penetration groove welds.
 - Shear stress on throat of weld (loading through the weld in any direction) is governed by Category F.
 - Slopes similar to those required by Note 3 are mandatory for categories listed. If slopes are not obtainable, Category E must be used.
 - Radii less than 2 in. (51 mm) need not be ground.
- (a) Except as noted for fillet and stud welds.

8/SPECIFICATION FOR WELDING OF INDUSTRIAL & MILL CRANES

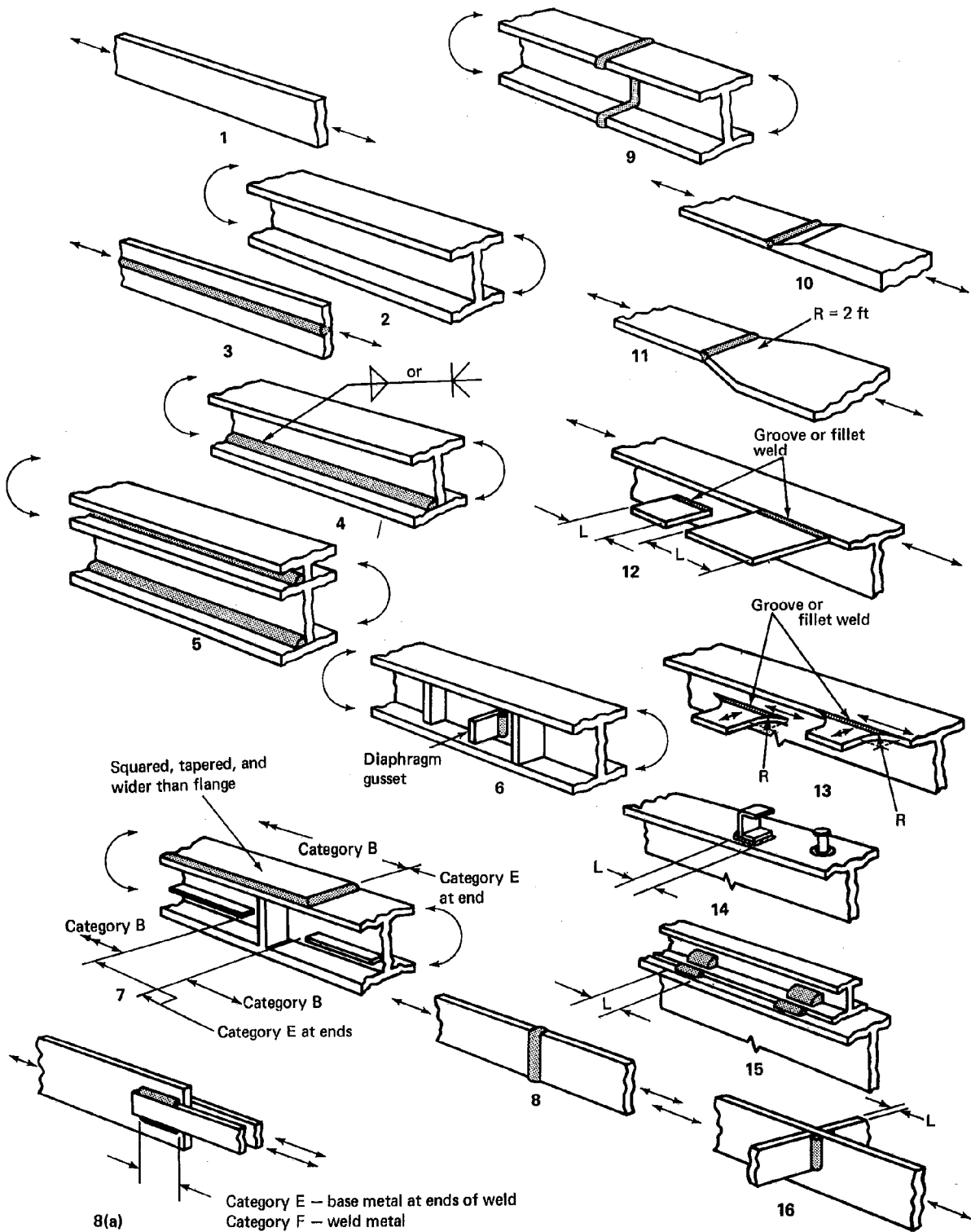

Note: The numbers below each example are referenced in Table 3B. Reprinted with the permission of the American Association of State Highway and Transportation Officials.

Fig. 1 - Examples of various fatigue categories

4. Weld Joint Design

4.1 General Requirements. Complete information regarding location, type, size, and extent of all welds and welded joints shall be shown on the drawings. Any special inspection requirements shall be noted on the drawings or other appropriate documents.

4.2 Groove Welds

4.2.1 The effective area of a full penetration weld shall be the effective weld length multiplied by the effective throat.

4.2.2 The effective length of any groove weld is the length throughout which the correctly proportioned weld cross section exists.

4.2.3 The effective throat is the minimum distance from the root of a weld to its face, less any reinforcement.

4.2.4 The effective throat of a partial penetration weld is joint penetration below the surface of the plate (See Table 4).

4.2.5 Groove welds made from one side only, except in secondary members, are prohibited unless they are completely fused to a backing strip, or qualified in accordance with the requirements of this specification (see 4.9).

4.2.6 A complete-joint-penetration groove weld is one that has been welded from both sides, or from one side, in which the weld metal completely fills the groove and is fused to the base metal throughout its total thickness (see 4.9).

4.3 Intermittent Groove Welds. Intermittent groove welds are prohibited, except in secondary members.

4.4 Fillet Welds (see Fig. 2)

4.4.1 The minimum fillet weld size shall be as shown in Table 5, except where fillet welds are used to reinforce groove welds (see Fig. 3).

4.4.2 The maximum fillet weld size permitted along the edges of members should be

(1) The thickness of the base metal when the metal is less than 1/4 in. (6 mm) thick.

(2) The thickness of the base metal less 1/16 in. (1.6 mm) when the metal is 1/4 in. (6 mm) or more in thickness, unless the designed weld size is equal to the base metal thickness to obtain the largest possible effective throat.

4.4.3 The effective weld area shall be the effective weld length multiplied by the effective throat. The shear stress in a fillet weld shall be considered as applied to this effective area regardless of the direction of applied load. The effective length of a fillet weld shall be the overall length of the full size fillet, including boxing (end returns).

4.4.4 Fillet welds terminated at ends or sides of parts or members shall, wherever practicable, be returned continuously around the corners for a distance at least twice the nominal size of the weld. It is preferable, however, to terminate the weld 1/2 in. (13 mm) around the corner.

4.4.5 Fillet welds in holes or slots may be used to transmit shear in lap joints, to prevent the buckling or separation of lapped parts, or to join components of built-up members. Fillet welds in holes or slots are not to be considered plug or slot welds.

4.4.6 Fillet welds shall not be used in skewed T-joints that have an included angle of less than 60 degrees. The edge of the abutting member shall be beveled, when necessary, to limit the root opening to 1/8 in. (3 mm) maximum.

4.5 Intermittent Fillet Welds

4.5.1 The length of any segment of intermittent fillet welds shall not be less than 4 times the weld size, with a minimum of 2 in. (51 mm); at least 25 percent of the joint shall be welded. Maximum spacing permitted between welds shall be 12 in. (300 mm).

4.5.2 Intermittent fillet welds may be used to carry calculated loads.

4.5.3 Intermittent fillet welds shall be no less than 2 in. (51 mm) in length at each end of the joint.

Table 4
Minimum effective throat for partial-joint-penetration groove welds

Metal thickness of thicker part joined		Minimum effective throat	
in.	mm	in.	mm
To 1/4 incl.	6 incl.	1/8	3
Over 1/4 to 1/2 incl.	6 to 13 incl.	3/16	5
Over 1/2 to 3/4 incl.	13 to 19 incl.	1/4	6
Over 3/4 to 1-1/2 incl.	19 to 38.1 incl.	5/16	8
Over 1-1/2 to 2-1/4 incl.	38.1 to 57.1 incl.	3/8	10
Over 2-1/4 to 6 incl.	57.1 to 152 incl.	1/2	13
Over 6	152	5/8	16

10/SPECIFICATION FOR WELDING OF INDUSTRIAL & MILL CRANES

Table 5
Minimum fillet weld size

Metal thickness of thicker part joined		Weld size ^a			
		Shielded metal arc welding		Deep penetration process ^b for single pass welds ^c flat U horizontal positions	
in.	mm	in.	mm	in.	mm
To 1/4 incl.	6	1/8	3	1/8	3
Over 1/4 to 1/2 incl.	6 to 13	3/16	5	1/8	3
Over 1/2 to 3/4 incl.	13 to 19	1/4	6	3/16	5
Over 3/4 and up	19	5/16	8	1/4	6

(a) Weld size need not exceed thickness of thinner member. Minimum weld size on bridge members flange-to-web is 3/16 in. (5 mm).
 (b) The intent of this table is not to establish the arc welding processes that provide deep penetration, but rather, to establish the typical allowable decrease of fillet weld size, provided the manufacturer can demonstrate that the required effective throat can be obtained by the qualified welding procedure in accordance with Section 7.
 (c) Also applies to the root pass of a multiple-pass weld.

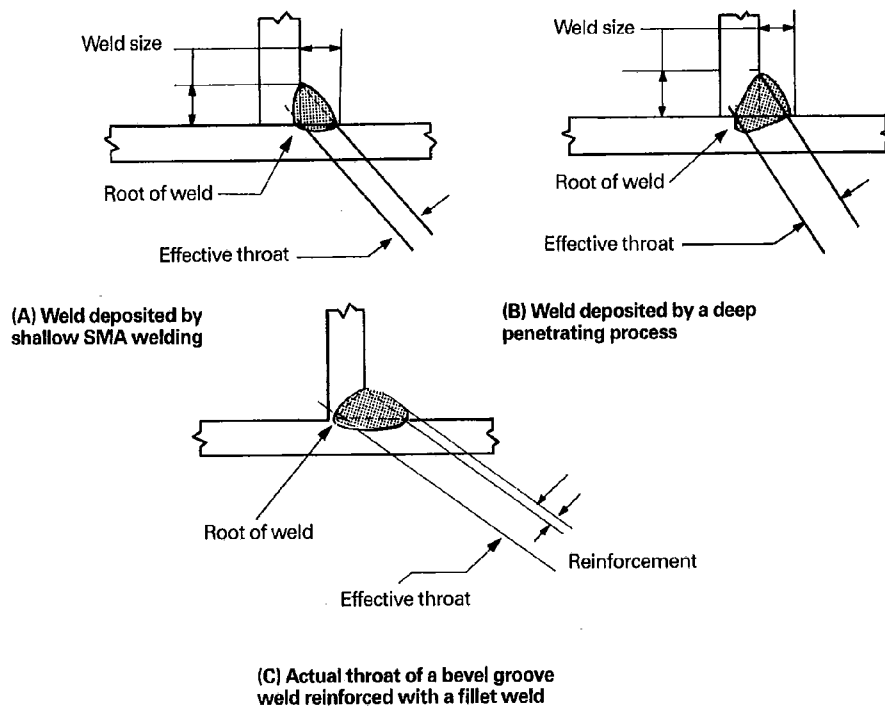

Fig. 2—Fillet and combined weld dimension

4.6 Staggered Intermittent Fillet Welds

4.6.1 When staggered intermittent fillet welds are used, the clear spacing shall be considered the distance between two consecutive welds even though they are on opposite sides of a plate (see Fig. 4).

4.6.2 When the total aggregate length of the staggered intermittent fillet weld is 90 percent or more of the joint length, any odd number of weld segments may be used, provided:

- (1) Welds are placed at each end of the joint on one side.
- (2) Clear spacing does not exceed 6 in. (152 mm).

4.7 Plug and Slot Welds

4.7.1 Plug or slot welds may be used to transmit shear loading in a lap joint, to prevent buckling or separation of lapped parts, or to join component parts of built-up members, except with quenched-and-tempered steels.

4.7.2 The effective area shall be the nominal area of the hole or slot in the plane of the faying surface.

4.7.3 The minimum diameter of the hole for a plug weld shall be no less than the thickness of the part containing it, plus 5/16 in. (8 mm). The maximum diameter of the hole shall not be greater than 2-1/4 times the thickness of the weld.

4.7.4 The length of the slot for a slot weld shall not exceed 10 times the thickness of the weld. The width of the slot shall not be less than the thickness of the part containing it plus 5/16 in. (8 mm), or greater than 2-1/4 times the thickness of the weld. The ends of the slot shall be semicircular or shall have the corners rounded to a radius not less than the thickness of the part containing it, except those ends which extend to the edge of the part.

4.7.5 The depth of filling of plug or slot welds in metal 5/8 in. (16 mm) thick or less shall be equal to the thick-

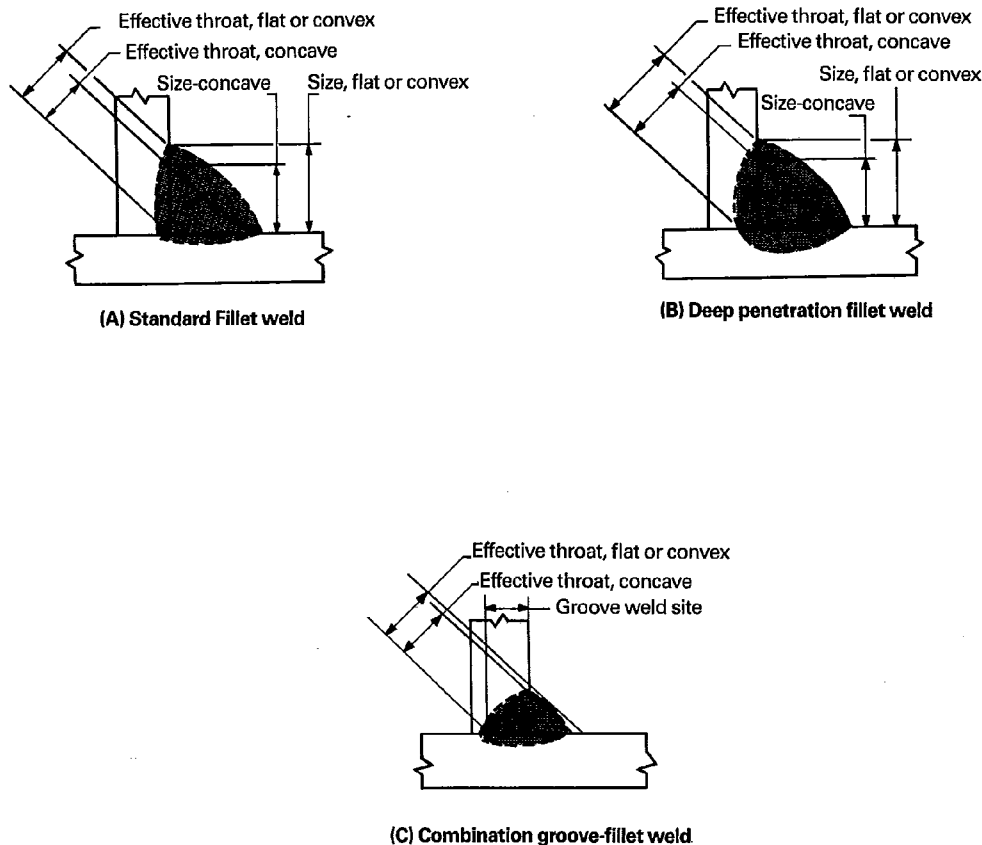
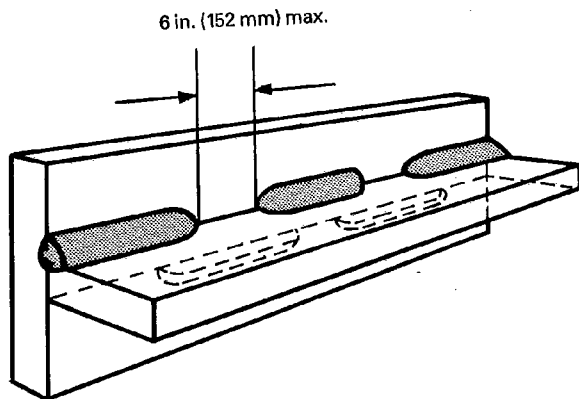

Fig. 3—Size and effective throat of fillet and combination groove-fillet welds

12/SPECIFICATION FOR WELDING OF INDUSTRIAL & MILL CRANES



(H) Staggered intermittent fillet weld

Fig. 4—Staggered intermittent fillet weld

ness of the metal. In metal over 5/8 in. (16 mm) thick, it shall be at least 1/2 the thickness of the metal but no less than 5/8 in. (16 mm).

4.8 Suggested Classification of Welded Joints

4.8.1 The classifications of welded joints for use in the design and manufacture of overhead material handling machinery and equipment are listed in 4.9 and detailed in Fig. 5.

4.8.2 These classifications can be used for qualification and examination of welded joints used in fabrication of equipment covered by this specification.

4.8.3 It is not the intent of these classifications to restrict the use of other proven methods and procedures that have achieved acceptable results, when agreed to in writing by the manufacturer and purchaser.

4.9 Weld Joint Categories

4.9.1 Category I. Double-welded butt joints with complete joint penetration. The root of the first weld is chipped, gouged, or ground to sound metal before making the second weld; and the weld faces are ground or machined flush with the direction of metal removal parallel to the principle stress. Welded joints that are made using backing tape, fusible flux backing material, or a nonfusible backing bar, and a back weld to obtain a completely fused root need only have the weld faces machined flush. Finished joints shall be nondestructively tested according to Section 8, and the results recorded.

4.9.2 Category II. Double-welded butt or T-joints with complete joint penetration. The root of the first weld is chipped, gouged, or ground to sound metal before making the second weld. Welded joints that are made using backing tape, fusible flux backing material, or a nonfusible backing bar, and a back weld to obtain a completely fused root do not require back gouging of the fillet weld.

Finished joints shall be nondestructively tested according to Section 8, and the results recorded.

4.9.3 Category III. Complete-joint-penetration butt, T-, and corner joint welded from both sides, or from one side using a backing strip that is not removed after welding.

4.9.4 Category IV. Complete-penetration butt, T-, and corner joints; partial-penetration butt, T-, and corner joints welded on both sides; and fillet-welded lap, T-, and corner joints welded on both sides.

4.9.5 Category V. Partial-joint-penetration butt, T-, and corner joints; and fillet-, plug-, or slot-welded lap, T-, and corner joints welded on one side only.

4.9.6 Category VI. Joints with no special weld groove preparation, such as butt, T-, corner, lap, or edge joints; plug welds in joints; welds of secondary importance in strength; and structural welded joints of secondary importance.

4.10 Joint Qualification

4.10.1 Joints meeting the following requirements are designated as prequalified:

(1) Conformance with the details of 4.2 through 4.6, and Figs. 6 & 7

(2) Welded with one of the following processes in accordance with the requirements of Section 6, as applicable: shielded metal arc, submerged arc, flux cored arc, and gas metal arc with other than short-circuiting transfer











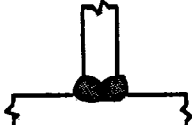

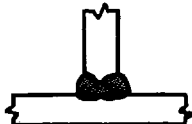
4.10.2 Other joint configurations may be used with proper qualification in accordance with Section 7.

4.11 Transition of Thicknesses or Widths at Butt Joints

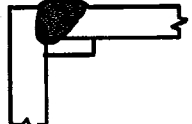
4.11.1 Butt joints between parts of unequal thicknesses and also subject to tensile stress shall have a smooth transition between the offset surfaces at a maximum slope of 1 in. (25.4 mm) with the adjacent surface of either part. The transition may be accomplished by sloping the weld face(s), by chamfering the thicker part, or by a combination of the two (see Fig. 8).

4.11.2 Transition of thickness in butt joints between parts of unequal thickness, that are subject only to shear of compressive stress, shall be accomplished as specified in 4.11.1 when the offset between surfaces at either side of the joint is greater than the thickness of the thinner part connected. When the offset does not exceed the thickness of the thinner part connected, the face of the weld shall be sloped (1) no more than 1 in. (25.4 mm) from the surface of the thinner part or (2) to the surface of the thicker part if this requires a lesser slope. The exception is that truss member joints and beam and girder flange joints shall be made with a smooth transition of the type specified in 4.11.1.

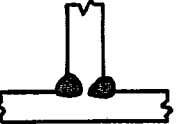
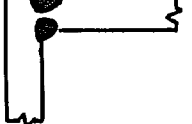
4.11.3 Butt joints between parts of unequal width that are subject to tensile stress shall have either (1) a smooth slope between offset edges of no more than 1 in. (25.4 mm)

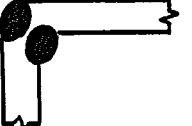
Category	Configuration of welded joints ^a		
I			
II			
III			
			
IV			
			
			

Note:

(a) Details of weld joint (groove design, root openings, etc.) are those required for the welding process to be used.

Fig. 5—Classification of welded joints

14/SPECIFICATION FOR WELDING OF INDUSTRIAL & MILL CRANES

Category	Configuration of welded joints ^a		
V			
VI			

Notes:
 (a) Details of weld joint (groove design, root opening, etc.) are those required for the welding process to be used.
 (b) The diameter of plug welds or the width of slot welds is indicated by dimension "d."

Fig. 5 (continued)—Classification of welded joints

Square-groove weld (1) Butt joint (B) Corner joint (C)									
M = Steel (see 4.12)									
Welding process	Joint designation	Base metal thickness (U = unlimited)		Groove preparation			Permitted welding positions	Gas shielding for (FCAW)	Notes
		T ₁	T ₂	Root opening	Tolerances				
					As detailed (see 4.13)	As fit up (see 5.4.4)			
SMAW	B-L1a	1/4 max	—	R=T ₁	+1/16,-0	+1/4,-1/16	All	—	—
	C-L1a	1/4 max	U	R=T ₁	+1/16,-0	+1/4,-1/16	All	—	—
GMAW FCAW	B-L1a-GF	3/8 max	—	R=T ₁	+1/16,-0	+1/4,-1/16	All	Not required	A

Square-groove weld (1) Butt joint (B)									
Welding process	Joint designation	Base metal thickness (U = unlimited)		Groove preparation			Permitted welding positions	Gas shielding for (FCAW)	Notes
		T ₁	T ₂	Root opening	Tolerances				
					As detailed (see 4.13)	As fit up (see 5.4.4)			
SMAW	B-L1b	1/4 max	—	R = T ₁ /2	+1/16,-0	+1/16,-1/8	All	—	C
GMAW FCAW	B-L1b-GF	3/8 max	—	R = 0 to 1/8	+1/16,-0	+1/16,-1/8	All	Not required	A,C
SAW	B-L1-S	1/2 max	—	R = 0	±0	+1/16, -0	Flat	—	D

Note A: Not prequalified for gas metal arc welding using short circuiting transfer.

Note C: Gouge root before welding second side.

Note D: Welds must be centered on joint.

Fig. 6—Prequalified complete joint penetration groove welded joints

16/SPECIFICATION FOR WELDING OF INDUSTRIAL & MILL CRANES

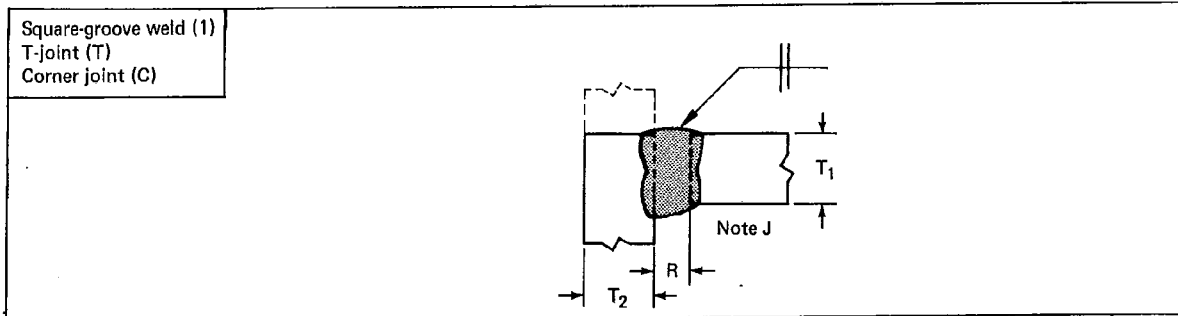

Welding process	Joint designation	Base metal thickness (U = unlimited)		Groove preparation			Permitted welding positions	Gas shielding for (FCAW)	Notes
		T ₁	T ₂	Root opening	Tolerances				
					As detailed (see 4.13)	As fit up (see 5.4.4)			
SMAW	TC-L1b	1/4 max	U	R = T ₁ /2	+1/16, -0	+1/16, -1/8	All	-	C, J
GMAW FCAW	TC-L1-GF	3/8 max	U	R = 0 to 1/8	+1/16, -0	+1/16, -1/8	All	Not req.	A, C, J
SAW	TC-L1-S	3/8 max	U	R = 0	±0	+1/16, -0	Flat	-	J, C

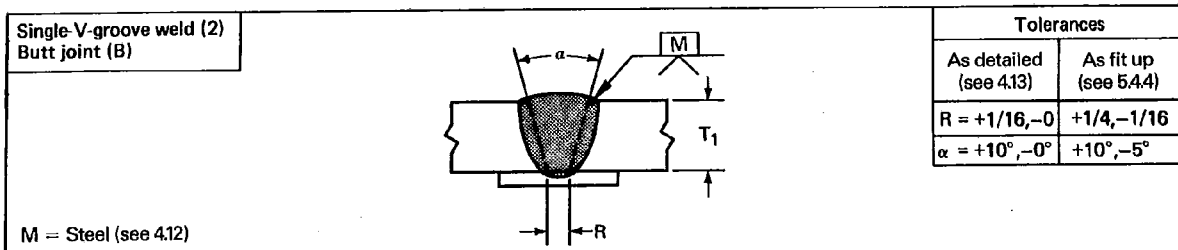

Welding process	Joint designation	Base metal thickness (U = unlimited)		Groove preparation		Permitted welding positions*	Gas shielding for (FCAW)	Notes
		T ₁	T ₂	Root opening	Groove angle			
GMAW FCAW	B-U2a-GF	U	-	R = 3/8	α = 30°	F, OH	-	-
				R = 1/2	α = 20°	F, OH	-	-
				R = 3/16	α = 30°	F, V, OH	Required	A
SAW	B-L2a-S	2 max	-	R = 3/8	α = 30°	F	Not req.	A
				R = 1/4	α = 30°	V, OH	Not req.	A
SAW	B-L2a-S	2 max	-	R = 1/4	α = 30°	F	-	-
SAW	B-U2-S	U	-	R = 5/8	α = 20°	F	-	-

Note A: Not prequalified for gas metal arc welding using short circuiting transfer.

Note C: Gouge root before welding other side.

Note J: If fillet welds are used to reinforce groove welds in corner and T-joints, they shall be equal to 1/4 T₁ but need not exceed 3/8 in. The reinforcement of groove welds in corner joints, when required, shall be made with fillet welds equal to 1/4 T₁, but need not exceed 3/8 in.

*F = Flat, OH = Overhead, V = Vertical

Fig. 6 (continued)—Prequalified complete joint penetration groove welded joints

Single-V-groove weld (2) Corner joint (C)		Base metal thickness		Groove preparation		Tolerances		Notes
Welding process	Joint designation	U = unlimited		Root opening	Groove angle	As detailed (see 4.13)	As fit up (see 5.4.4)	
		T ₁	T ₂			R = +1/16, -0	+1/4, -1/16	
						$\alpha = +10^\circ, -0^\circ$	+10°, -5°	
								M = Steel (see 4.12)
SMAW	C-U2a	U	U	R = 1/4	$\alpha = 45^\circ$	All	-	-
				R = 3/8	$\alpha = 30^\circ$	F, OH	-	-
				R = 1/2	$\alpha = 20^\circ$	F, OH	-	-
GMAW FCAW	C-U2a-GF	U	U	R = 3/16	$\alpha = 30^\circ$	F, V, OH	Required	A
				R = 3/8	$\alpha = 30^\circ$	F	Not req.	A
				R = 1/4	$\alpha = 30^\circ$	V, OH	Not req.	A
SAW	C-L2a-S	1/2 max	U	R = 1/4	$\alpha = 30^\circ$	F	-	-
SAW	C-U2-S	U	U	R = 5/8	$\alpha = 20^\circ$	F	-	-

Single V-groove weld (2) Butt joint (B)		Base metal thickness		Groove preparation		Permitted welding positions	Gas shielding for (FCAW)	Notes
Welding process	Joint designation	U = unlimited		Root opening Root face Groove angle	Tolerances			
		T ₁	T ₂		As detailed (see 4.13)	As fit up (see 5.4.4)		
SMAW	B-U2	U	-	R = 0 to 1/8 f = 0 to 1/8 $\alpha = 60^\circ$	+1/16, -0 +1/16, -0 +10°, -0°	+1/16, -1/8 Not limited +10°, -5°	-	C
GMAW FCAW	B-U2-GF	U	-	R = 0 to 1/8 f = 0 to 1/8 $\alpha = 60^\circ$	+1/16, -0 +1/16, -0 +10°, -0°	+1/16, -1/8 Not limited +10°, -5°	Not required	A, C,
SAW	B-L2b-S	over 1/2 to 1 inclusive	-	R = 0 f = 1/4 max $\alpha = 60^\circ$	± 0 +0, -1/4 +10, -0	+1/16, -0 $\pm 1/16$ +10, -5	-	K
SAW	B-L2c-S	Over 1/2 to 1	-	R = 0, $\alpha = 60^\circ$ f = 1/4 max	R = ± 0 f = +0, -f $\alpha = +10^\circ, -0^\circ$	+1/16, -0 $\pm 1/16$ +10°, -5°	-	C
		Over 1 to 1-1/2	-	R = 0, $\alpha = 60^\circ$ f = 1/2 max				
		Over 1-1/2 to 2	-	R = 0, $\alpha = 60^\circ$ f = 5/8 max				

Note A: Not prequalified for gas metal arc welding using short circuiting transfer.

Note C: Gouge root before welding other side.

Note K: Weld root after welding at least one pass on arrows side.

*F = Flat, OH = Overhead, V = Vertical

Fig. 6 (continued)—Prequalified complete joint penetration groove welded joints

18/SPECIFICATION FOR WELDING OF INDUSTRIAL & MILL CRANES

Single-V-groove weld (2) Corner joint (C)		Base metal thickness (U = unlimited)		Groove preparation			Permitted welding position*	Gas shielding for (FCAW)	Notes
Welding process	Joint designation	T ₁	T ₂	Root opening Root face Groove angle	Tolerances				
					As detailed (see 4.13)	As fit up (see 5.4.4)			
SMAW	C-U2	U	U	R = 0 to 1/8 f = 0 to 1/8 α = 60°	+1/16, -0 +1/16, -0 +10°, -0°	+1/16, -1/8 Not limited +10°, -5°	All	-	C,J
GMAW FCAW	C-U2-GF	U	U	R = 0 to 1/8 f = 0 to 1/8 α = 60°	+1/16, -0 +1/16, -0 +10°, -0°	+1/16, -1/8 Not limited +10°, -5°	All	Not required	A,C,J
SAW	C-L2b-S	1 max	U	R = 0 f = 1/4 max α = 60°	±0 +0, -1/4 +10°, -0°	+1/16, -0 ±1/16 +10°, -5°	F	-	J,K

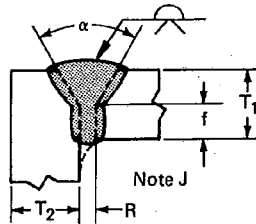

Double-V-groove weld (3) Butt joint (B)		Base metal thickness (U = unlimited)		Groove preparation			Permitted welding positions*	Gas shielding for FCAW	Notes
Welding process	Joint designation	T ₁	T ₂	Root opening	Root face	Groove angle			
							SMAW	B-U3a	U preferably 5/8 or thicker Spacer = 1/8 x R
SAW	B-U3a-S	U Spacer = 1/4 x R	-	R = 5/8	f = 0 to 1/4	α = 20°	F	-	M

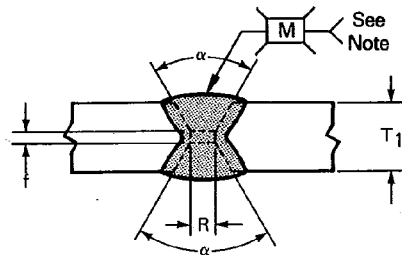

Tolerances	
As detailed (see 4.13)	As fit up (see 5.4.4)
R = ±0	+1/4, -0
f = ±0	+1/16, -0
α = +10°, -0°	+10°, -5°
Spacer = ±0	+1/16, -0

M = Steel (see 4.12)

Note A: Not prequalified for gas metal arc welding using short circuit transfer.

Note C: Gouge root before welding other side.

Note J: If fillet welds are used to reinforce groove welds in corner and T-joints, they shall be equal to 1/4 T₁ but need not exceed 3/8 in. (9.5 mm). The reinforcement of groove welds in corner joints, when required, shall be made with fillet welds equal to 1/4 T₁ but need not exceed 3/8 in. (9.5 mm).

Note K: Weld root after welding at least one pass on arrow side.

Note M: Double-groove welds may have grooves of unequal depth, but the depth of the shallower groove shall be no less than one-fourth of the thickness of the thinner part joined.

*F = Flat, OH = Overheads, V = Verticle

Fig. 6 (continued)—Prequalified complete joint penetration groove welded joints

Double-V-groove weld (3) Butt joint (B)		Base metal thickness (U = unlimited)		Groove preparation			Permitted welding positions	Gas shielding for (FCAW)	Notes
Welding process	Joint designation	T ₁	T ₂	Root opening Root face Groove angle	Tolerances				
					As detailed (see 2.9.2)	As fit up (see 3.3.4)			
SMAW	B-U3b	U	—	R = 0 to 1/8 f = 0 to 1/8 α = β = 60°	+1/16, -0 +1/16, -0 +10°, -0	+1/16, -1/8 Not limited +10°, -5°	All	—	C,M
GMAW FCAW	B-U3-GF	preferably 5/8 or thicker	—	R = 0 to 1/8 f = 0 to 1/8 α = β = 60°	+1/16, -0 +1/16, -0 +10°, -0	+1/16, -1/8 Not limited +10°, -5°	All	Not required	A,C,M
SAW	B-U3b-S	1-1/8 min	—	R = 1/8 f = 0 α = β = 60° S ₁ = 2/3 T ₁ , S ₂ = 3/8 min	+1/16, -0 +1/16, -0 +10°, -0	+1/16, -1/8 Not limited +10°, -5	Flat	—	M,P X
SAW	B-L3-S	1-1/2 max	—	R = 0 f = 1/4 max α = 60, β = 80 S ₁ = 2/3 (T ₁ - 1/4) S ₂ = 1/3 (T ₁ - 1/4)	±0 +0, -1/4 +10, -0	+1/16, -0 Not limited +10, -5	Flat	—	M,K
SAW	B-U3c-S	U	—	R = 0 f = 1/4 min α = β = 60° To find S ₁ see table above; S ₂ = T ₁ - (S ₁ + 1/4)	+1/16, -0 +1/4, -0 +10°, -0°	+1/16, -0 Not limited +10°, -5°	Flat	—	C,M

For B-U3c-S only		
T ₁		S ₁
Over	to	
2	2-1/2	1-3/8
2-1/2	3	1-3/4
3	3-5/8	2-1/8
3-5/8	4	2-3/8
4	4-3/4	2-3/4
4-3/4	5-1/2	3-1/4
5-1/2	6-1/4	3-3/4

For T₁ > 6-1/4, or T₁ ≤ 2
S₁ = 2/3 (T₁ - 1/4)

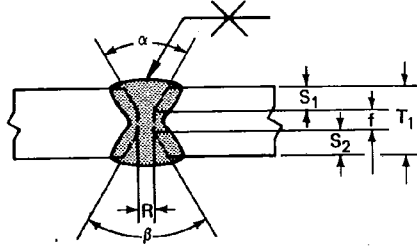

- Note A: Not prequalified for gas metal arc welding using short circuiting transfer.
- Note C: Gouge root before welding second side.
- Note K: Weld root after welding at least one pass on arrow side.
- Note M: Double-groove welds may have grooves of unequal depth, but the depth of the shallower groove shall be no less than one-fourth of the thickness of the thinner part joined.
- Note P: Weld S₂ first with shielded metal arc low-hydrogen electrodes. Root of this weld shall be back gouged. Weld S₁ with single or multiple pass submerged arc weld in flat position after manual arc welding is completed on other side.
- Note X: It is permissible for the groove opening to vary from 0— 1/8 in., in which case, weld as follows: Weld the S₁ groove first with shielded metal arc using low hydrogen electrodes; complete the weld with submerged arc welding. The root of the SMAW weld shall be back gouged. Weld the S₂ groove with shielded metal arc using low hydrogen electrode or by submerged arc welding.

Fig. 6 (continued)—Prequalified complete joint penetration groove welded joints

20/SPECIFICATION FOR WELDING OF INDUSTRIAL & MILL CRANES

Single-bevel-groove weld (4) Butt joint (B)		Base metal thickness (U = unlimited)		Groove preparation		Tolerances		
Welding process	Joint designation	T ₁	T ₂	Root opening	Groove angle	As detailed (see 4.13)	As fit up (see 5.4.4)	
						Permitted welding positions*	Gas shielding	Notes
				R = 1/4	α = 45°	All	—	Br
				R = 3/8	α = 30°	F,OH	—	Br
				R = 3/16	α = 30°	All	Required	—
				R = 1/4	α = 45°	All	Required	—
				R = 3/8	α = 30°	Flat	Not req.	—

Single-bevel-groove-weld (4) T-joint (T) Corner joint (C)		Base metal thickness (U = unlimited)		Groove preparation		Tolerances		
Welding process	Joint designation	T ₁	T ₂	Root opening	Groove angle	As detailed (see 4.13)	As fit up (see 5.4.4)	
						Permitted welding positions*	Gas shielding for (FCAW)	Notes
				R = 1/4	α = 45°	All	—	J,V
				R = 3/8	α = 30°	F,OH	—	J,V
				R = 3/16	α = 30°	All	Required	A,J,V
				R = 3/8	α = 30°	Flat	Not req.	A,J,V
				R = 1/4	α = 45°	All	Not req.	A,J,V
				R = 3/8	α = 30°	Flat	—	J,V
				R = 1/4	α = 45°			

Note A: Not prequalified for gas metal arc welding using short circuiting transfer.

Note Br: Bridge application limits these joints to the horizontal position.

Note J: If fillet welds are used to reinforce groove welds in corner and T-joints, they shall be equal to 1/4 T₁ but need not exceed 3/8 in. (9.5 mm). The reinforcement of groove welds in corner joints, when required, shall be made with fillet welds equal to 1/4 T₁, but need not exceed 3/8 in. (9.5 mm).

Note V: For corner joints, the outside groove preparation may be in either or both members, provided the basic groove configuration is not changed and adequate edge distance is maintained to support the welding operations without excessive edge melting.

*F = Flat, OH = Overhead

Fig. 6 (continued)—Prequalified complete joint penetration groove welded joints

Single-bevel-groove weld (4) Butt joint (B)		Base metal thickness (U = unlimited)		Groove preparation			Permitted welding positions	Gas shielding for (FCAW)	Notes
Welding process	Joint designation	T ₁	T ₂	Root opening Root face Groove angle	Tolerances				
					As detailed (see 4.13)	As fit up (see 5.4.4)			
SMAW	B-U4b	U	-	R = 0 to 1/8 f = 0 to 1/8 α = 45°	+1/16, -0 +1/16, -0 +10°, -0°	+1/16, -1/8 not limited +10°, -5°	All	-	C
GMAW FCAW	B-U4b-GF	U	-				All	Not required	A,C

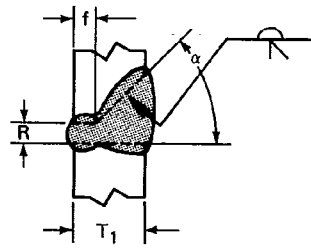

Single-bevel-groove weld (4) T-joint (T) Corner joint (C)		Base metal thickness (U = unlimited)		Groove preparation			Permitted welding positions	Gas shielding for (FCAW)	Notes
Welding process	Joint designation	T ₁	T ₂	Root opening Root face Groove angle	Tolerances				
					As detailed (see 4.13)	As fit up (see 5.4.4)			
SMAW	TC-U4a	U	U	R = 0 to 1/8 f = 0 to 1/8 α = 45°	+1/16, -0 +1/16, -0 +10°, -0°	+1/16, -1/8 Not limited +10°, -5°	All	-	C,J,V
GMAW FCAW	TC-U4a-GF	U	U				All	Not req.	A,C,J V
SAW	TC-U4a-S	3/4 max	U	R = 0 f = 1/8 max α = 60°	±0 +0, -1/8 +10°, -0°	+1/4, -0 ±1/16 +10°, -5°	Flat	-	J,V, Y

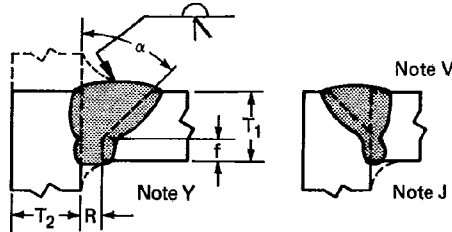

Note A: Not prequalified for gas metal arc welding using short circuiting transfer.

Note C: Gouge root before welding second side.

Note J: If fillet welds are used to reinforce groove welds in corner and T-joints, they shall be equal to 1/4 T₁ but need not exceed 3/8 in. (9.5 mm). The reinforcement of groove welds in corner joints, when required, shall be made with fillet welds equal to 1/4 T₁ but need not exceed 3/8 in. (9.5 mm).

Note V: For corner joints, the outside groove preparation may be in either or both members, provided the basic groove configuration is not changed and adequate edge distance is maintained to support the welding operations without excessive edge melting.

Note: Y: Shielded metal arc or submerged arc backing fillet weld required.

Fig. 6 (continued)—Prequalified complete joint penetration groove welded joints

22/SPECIFICATION FOR WELDING OF INDUSTRIAL & MILL CRANES

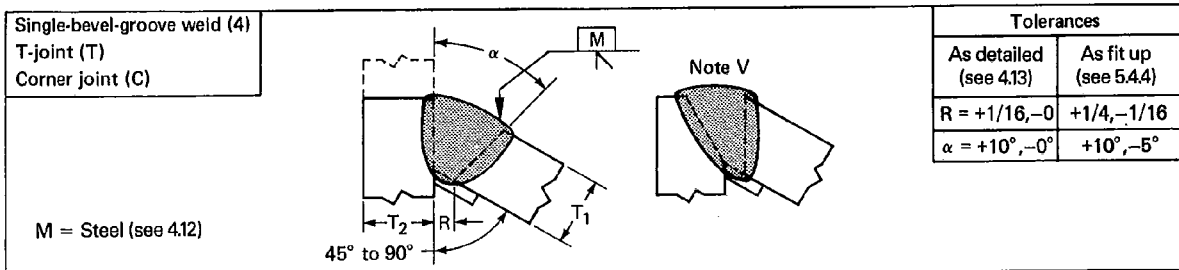

Welding process	Joint designation	Base metal thickness (U = unlimited)		Groove preparation		Permitted welding positions*	Gas shielding for (FCAW)	Notes
		T ₁	T ₂	Root opening	Groove angle			
SMAW	TC-U4d	U	U	R = 1/4	α = 45°	All	-	J,V
				R = 3/8	α = 30°	F,OH	-	
GMAW FCAW	TC-U4d-GF	U	U	R = 3/16	α = 30°	All	Required	A,J,V
				R = 3/8	α = 30°	Flat	Not req.	
				R = 1/4	α = 45°	All		
SAW	TC-U4b-S	U	U	R = 3/8	α = 30°	Flat	-	J,V
				R = 1/4	α = 45°			

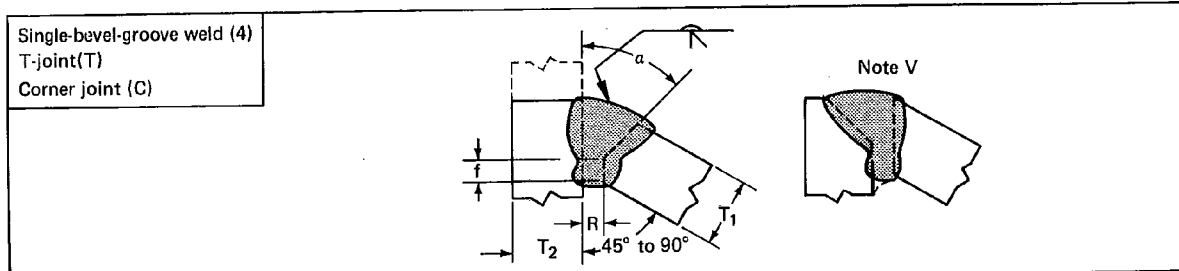

Welding process	Joint designation	Base metal thickness (U = unlimited)		Root opening	Tolerances		Permitted welding positions	Gas shielding for (FCAW)	Notes
		T ₁	T ₂		Root face	As detailed (see 4.13)			
				Groove angle					
SMAW	TC-U4b	U	U	R = 0 to 1/8	+1/16, -0	+1/16, -1/8	All	-	C,J,V
GMAW FCAW	TC-U4b-GF	U	U	f = 0 to 1/8	+1/16, -0	Not limited	All	Not required	A,C J,V
				α = 45°	+10°, -0°				
SAW	TC-L4b-S	3/4 max	U	R = 0 f = 1/8 max α = 60°	±0 +0, -1/8 +10°, -0°	+1/4, -0 ±1/16 +10°, -5°	Flat	-	J, V, Y

Note A: Not prequalified for gas metal arc welding using short circuiting transfer.

Note C: Gouge root before welding second side.

Note J: If fillet welds are used to reinforce groove welds in corner and T-joints, they shall be equal to 1/4 T₁ but need not exceed 3/8 in. (9.5 mm).

Note V: For corner joints, the outside groove preparation may be in either or both members, provided the basic groove configuration is not changed and adequate edge distance is maintained to support the welding operations without excessive edge melting.

Note Y: Shielded metal arc or submerged arc backing weld required.

*F = Flat, OH = Overhead

Fig. 6. (continued)—Prequalified complete joint penetration groove welded joints

Double-bevel-groove weld (5) Butt joint (B) T-joint (T) Corner joint (C)					Tolerances	
M = Steel (see 4.12) Note: Same steel as base metal					As detailed (see 4.13)	As fit up (see 5.4.4)
					$R = \pm 0$	$+1/16, -0$
					$f = +1/16, -0$	$\pm 1/16$
					$\alpha = +10^\circ, -0^\circ$	$+10^\circ, -5^\circ$
					Spacer = +0	$+1/16, -0$

Welding process	Joint designation	Base metal thickness (U = unlimited)		Groove preparation			Permitted welding positions*	Gas shielding for (FCAW)	Notes
		T ₁	T ₂	Root opening	Root face	Groove angle			
SMAW	B-U5b	U, preferably 5/8 or thicker Spacer = 1/8 X R	-	R = 1/4	f = 0 to 1/8	$\alpha = 45^\circ$	All	-	C, M
	TC-U5a	U, preferably 5/8 or thicker Spacer = 1/8 X R	U	R = 1/4	f = 0 to 1/8	$\alpha = 45^\circ$	All	-	C, J, M, V
R = 3/8				f = 0 to 1/8	$\alpha = 30^\circ$	F, OH	-	C, J, M, V	

Note C: Gouge root before welding other side.

Note J: If fillet welds are used to reinforce groove welds in corner and T-joints, they shall be equal to 1/4 T₁ but need not exceed 3/8 in. (9.5 mm). The reinforcement of groove welds in corner joints, when required, shall be made with fillet welds equal to 1/4 T₁ but need not exceed 3/8 in. (9.5 mm).

Note M: Double-groove welds may have grooves of unequal depth, but the depth of the shallower groove shall be no less than one-fourth of the thickness of the thinner part joined.

Note V: For corner joints, the outside groove preparation may be in either or both members, provided the basic groove configuration is not changed and adequate edge distance is maintained to support the welding operations without excessive edge melting.

*F = Flat, OH = Overhead

Fig. 6 (continued)—Prequalified complete joint penetration groove welded joints

24/SPECIFICATION FOR WELDING OF INDUSTRIAL & MILL CRANES

Double-bevel-groove weld (5) Butt joint (B)									
Welding process	Joint designation	Base metal thickness (U = unlimited)		Groove preparation Root opening Root face Groove angles	Tolerances		Permitted welding positions	Gas shielding for (FCAW)	Notes
		T ₁	T ₂		As detailed (see 4.13)	As fit up (see 5.4.4)			
SMAW	B-U5a	U preferably 5/8 or thicker	-	R = 0 to 1/8 f = 0 to 1/8 α = 45° β = 0° to 15°	+1/16, -0 +1/16, -0 α + β, +10° -0°	+1/16, -1/8 Not limited +10° α + β, -5°	All	-	C,M,Z
GMAW FCAW	B-U5-GF	U preferably 5/8 or thicker	-	R = 0 to 1/8 f = 0 to 1/8 α = 45° β = 0°	+1/16, -0 +1/16, -0 +10° - 0° ± 0	+1/16, -1/8 Not limited +10°, -5° -	All	Not req.	A,C,M

Double-bevel-groove weld (5) T-joint(T) Corner joint (C)									
Welding process	Joint designation	Base metal thickness (U = unlimited)		Groove preparation Root opening Root face Groove angle	Tolerances		Permitted welding positions	Gas shielding for (FCAW)	Notes
		T ₁	T ₂		As detailed (see 2.9.2)	As fit up (see 3.3.4)			
SMAW	TC-U5b	U preferably 5/8 or thicker	U	R = 0 to 1/8 f = 0 to 1/8 α = 45°	+1/16, -0 +1/16, -0 +10°, -0°	+1/16, -1/8 Not limited +10°, -5°	All	-	C,J,M, V
GMAW FCAW	TC-U5-GF	U preferably 5/8 or thicker	U				All	Not required	A,C,J, M,V
SAW	TC-U5-S	U	U	R = 0 f = 3/16 max α = 60°	± 0 +0, -3/16 +10°, -0°	+1/16, -0 ± 1/16 +10°, -5°	Flat	-	J,M,V

- Note A: Not prequalified for gas metal arc welding using short circuiting transfer.
- Note C: Gouge root before welding other side.
- Note J: If fillet welds are used to reinforce groove welds in corner and T-joints, they shall be equal to 1/4 T₁ but need not exceed 3/8 in. (9.5 mm). The reinforcement of groove welds in corner joints, when required, shall be made with fillet welds equal to 1/4 T₁ but need not exceed 3/8 in. (9.5 mm).
- Note M: Double-groove welds may have grooves of unequal depth, but the depth of the shallower groove shall be no less than one-fourth of the thickness of the thinner part joined.
- Note V: For corner joints, the outside groove preparation may be in either or both members, provided the basic groove configuration is not changed and adequate edge distance is maintained to support the welding operations without excessive edge melting.
- Note Z: When lower plate is beveled, make the first root pass on this side.

Fig. 6 (continued)—Prequalified complete joint penetration groove welded joints

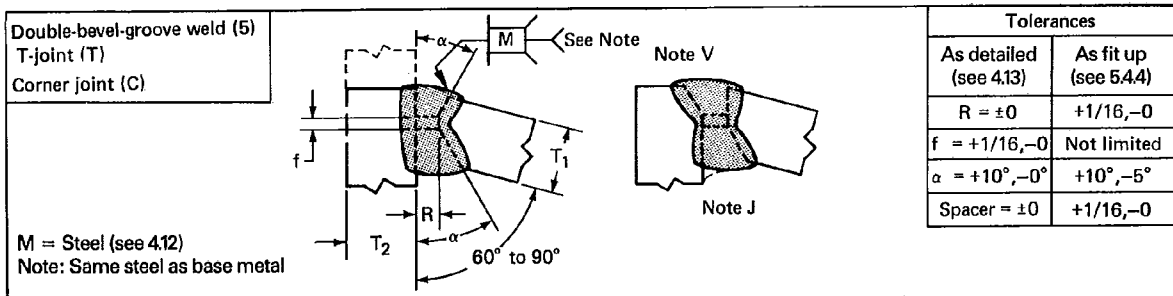

Tolerances	
As detailed (see 4.13)	As fit up (see 5.4.4)
R = ±0	+1/16, -0
f = +1/16, -0	Not limited
α = +10°, -0°	+10°, -5°
Spacer = ±0	+1/16, -0

Welding process	Joint designation	Base metal thickness (U = unlimited)		Groove preparation			Permitted welding positions*	Gas shielding for (FCAW)	Notes
		T ₁	T ₂	Root opening	Root face	Groove angle			
SMAW	TC-U5c	U, preferably 5/8 or thicker Spacer = 1/8 X R	U	R = 1/4	f = 0 to 1/8	α = 45°	All	-	C, J, V, M
				R = 3/8	f = 0 to 1/8	α = 30°			

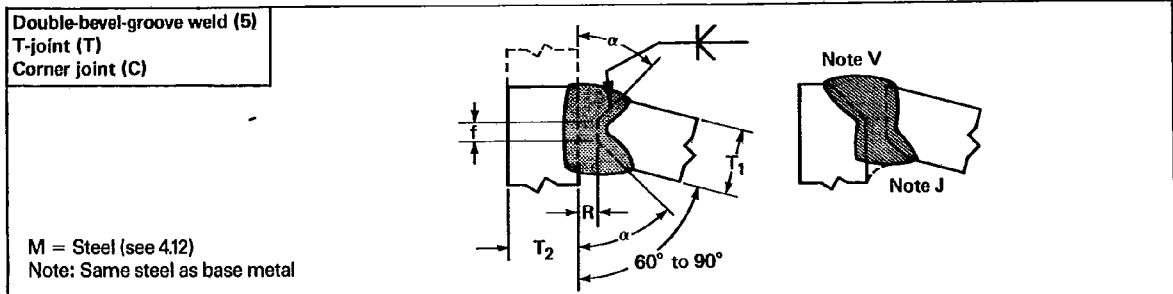

Welding process	Joint designation	Base metal thickness (U = unlimited)		Root opening	Tolerances		Permitted welding positions	Gas shielding for (FCAW)	Notes
		T ₁	T ₂		Root face	As detailed (see 4.13)			
		Groove preparation			Groove angle				
SMAW	TC-U5d	U, preferably 5/8 or thicker	U	R = 0 to 1/8 f = 0 to 1/8 α = 45°	+1/16, -0 +1/16, -0 +10°, -0°	+1/16, -1/8 Not limited +10°, -5°	All	-	C, J, V, M

Note C: Gouge root before welding other side.

Note J: If fillet welds are used to reinforce groove welds in corner and T-joints, they shall be equal to 1/4 T₁ but need not exceed 3/8 in. (9.5 mm).

Note M: Double-groove welds may have grooves of unequal depth, but the depth of the shallower groove shall be no less than one-fourth of the thickness of the thinner part joined.

Note V: For corner joints, the outside groove preparation may be in either or both members, provided the basic groove configuration is not changed and adequate edge distance is maintained to support the welding operations without excessive edge melting.

*F = Flat, OH = Overhead

Fig. 6 (continued)—Prequalified complete joint penetration groove welded joints

26/SPECIFICATION FOR WELDING OF INDUSTRIAL & MILL CRANES

Single-U-groove weld (6) Butt joint (B) Corner joint (C)		Base metal thickness (U = unlimited)		Groove preparation				Permitted welding positions*	Gas shielding for (FCAW)	Notes
Welding process	Joint designation	T ₁	T ₂	Root opening	Groove angle	Root face	Groove radius			
		SMAW	B-U6	U	U	R = 0 to 1/8	α = 45°	f = 1/8	r = 1/4	All
R = 0 to 1/8	α = 20°					f = 1/8	r = 1/4	F,OH	-	C
C-U6	U		U	R = 0 to 1/8	α = 45°	f = 1/8	r = 1/4	All	-	C,J
				R = 0 to 1/8	α = 20°	f = 1/8	r = 1/4	F,OH	-	C,J
GMAW FCAW	B-U6-GF	U	U	R = 0 to 1/8	α = 20°	f = 1/8	r = 1/4	All	Not req.	A,C
	C-U6-GF	U	U	R = 0 to 1/8	α = 20°	f = 1/8	r = 1/4	All	Not req.	A,C,J

Double-U-groove weld (7) Butt joint (B)		Base metal thickness (U = unlimited)		Groove preparation				Permitted welding positions*	Gas shielding for (FCAW)	Notes
Welding process	Joint designation	T ₁	T ₂	Root opening	Groove angle	Root face	Groove radius			
		SMAW	B-U7	U preferably 5/8 or thicker	-	R = 0 to 1/8	α = 45°	f = 1/8	r = 1/4	All
R = 0 to 1/8	α = 20°					f = 1/8	r = 1/4	F,OH	-	C,M
GMAW FCAW	B-U7-GF	U preferably 5/8 or thicker	-	R = 0 to 1/8	α = 20°	f = 1/8	r = 1/4	All	Not required	A,C,M
SAW	B-U7-S	U	-	R = 0	α = 20°	f = 1/4 max	r = 1/4	F	-	M

Note A: Not prequalified for gas metal arc welding using short circuiting transfer.

Note C: Gouge root before welding other side.

Note J: If fillet welds are used in buildings to reinforce groove welds in corner and T-joints, they shall be equal to 1/4 T₁ but not exceed 3/8 in. (9.5 mm). The reinforcement of groove welds in corner joints, when required, shall be made with fillet welds equal to 1/4 T₁ but not more than 3/8 in. (9.5 mm).

Note M: Double-groove welds may have grooves of unequal depth, but the depth of the shallower groove shall be no less than one-fourth of the thickness of the thinner part joined.

*F = Flat, OH = Overhead

Fig. 6 (continued)—Prequalified complete joint penetration groove welded joints

Single-J-groove weld (B) Butt joint (B)						Tolerances	
						As detailed (see 4.13)	As fit up (see 5.4.4)
						$R = +1/16, -0$	$+1/16, -1/8$
						$\alpha = +10^\circ, -0^\circ$	$+10^\circ, -5^\circ$
						$f = +1/16, -0$	Not limited
						$r = +1/4, -0$	$\pm 1/16$

Welding process	Joint designation	Base metal thickness (U = unlimited)		Groove preparation				Permitted welding positions	Gas shielding for (FCAW)	Notes
		T ₁	T ₂	Root opening	Groove angle	Root face	Groove radius			
SMAW	B-U8	U	-	R = 0 to 1/8	$\alpha = 45^\circ$	f = 1/8	r = 3/8	All	-	C
GMAW FCAW	B-U8-GF	U	-	R = 0 to 1/8	$\alpha = 30^\circ$	f = 1/8	r = 3/8	All	Not required	A,C

Single-J-groove weld (B) T-joint (T) Corner joint (C)						Tolerances	
						As detailed (see 4.13)	As fit up (see 5.4.4)
						$R = +1/16, -0$	$+1/16, -1/8$
						$\alpha = +10^\circ, -0^\circ$	$+10^\circ, -5^\circ$
						$f = +1/16, -0$	Not limited
						$r = +1/4, -0$	$\pm 1/16$

Welding process	Joint designation	Base metal thickness (U = unlimited)		Groove preparation				Permitted welding positions*	Gas shielding for (FCAW)	Notes
		T ₁	T ₂	Root opening	Groove angle	Root face	Groove radius			
SMAW	TC-U8a	U	U	R = 0 to 1/8	$\alpha = 45^\circ$	f = 1/8	r = 3/8	All	-	C ₁ ,J,V
				R = 0 to 1/8	$\alpha = 30^\circ$	f = 1/8	r = 3/8	F,OH	-	C ₁ ,J,V
GMAW FCAW	TC-U8a-GF	U	U	R = 0 to 1/8	$\alpha = 30^\circ$	f = 1/8	r = 3/8	All	Not required	A,C,J, V

Note A: Not prequalified for gas metal arc welding using short circuiting transfer.

Note C: Gouge root before welding other side.

Note J: If fillet welds are used in buildings to reinforce groove welds in corner and T-joints, they shall be equal to 1/4 T₁ but not exceed 3/8 in. (9.5 mm). The reinforcement of groove welds in corner joints, when required, shall be made with fillet welds equal to 1/4 T₁ but not more than 3/8 in. (9.5 mm).

Note V: For corner joints, the outside groove preparation may be in either or both members, provided the basic groove configuration is not changed and adequate edge distance is maintained to support the welding operations without excessive edge melting.

*F = Flat, OH = Overhead

Fig. 6 (continued)—Prequalified complete joint penetration groove welded joints

28/SPECIFICATION FOR WELDING OF INDUSTRIAL & MILL CRANES

Single-J-groove weld (8) T-joint (T) Corner joint (C)		Tolerances	
		As detailed (see 4.13)	As fit up (see 5.4.4)
		$R = +1/16, -0$	$+1/16, -1/8$
		$\alpha = +10^\circ, -0^\circ$	$+10^\circ, -5^\circ$
		$f = +1/16, -0$	Not limited
		$r = +1/4, -0$	$\pm 1/16$

Welding process	Joint designation	Base metal thickness (U = unlimited)		Groove preparation				Permitted welding positions*	Gas shielding for (FCAW)	Notes
		T ₁	T ₂	Root opening	Groove angle	Root face	Groove radius			
SMAW	TC-U8b	U	U	R = 0 to 1/8	$\alpha = 45^\circ$	f = 1/8	r = 3/8	All	-	C,J,V
				R = 0 to 1/8	$\alpha = 30^\circ$	f = 1/8	r = 3/8	F,OH	-	C,J,V
GMAW FCAW	TC-U8b-GF	U	U	R = 0 to 1/8	$\alpha = 30^\circ$	f = 1/8	r = 3/8	All	Not required	A,C, J,V

Double-J-groove weld (9) Butt joint (B)		Tolerances	
		As detailed (see 4.13)	As fit up (see 5.4.4)
		$R = +1/16, -0$	$+1/16, -1/8$
		$\alpha = +10^\circ, -0^\circ$	$+10^\circ, -5^\circ$
		$f = +1/16, -0$	Not limited
		$r = + 1/4, -0$	$\pm 1/16$

Welding process	Joint designation	Base metal thickness (U = unlimited)		Groove preparation				Permitted welding positions	Gas shielding for (FCAW)	Notes
		T ₁	T ₂	Root opening	Groove angle	Root face	Groove radius			
SMAW	B-U9	U preferably 5/8 or thicker	-	R = 0 to 1/8	$\alpha = 45^\circ$	f = 1/8	r = 3/8	All	-	C, M
GMAW FCAW	B-U9-GF	U preferably 5/8 or thicker	-	R = 0 to 1/8	$\alpha = 30^\circ$	f = 1/8	r = 3/8	All	Not required	A,C,M

Note A: Not prequalified for gas metal arc welding using short circuiting transfer.

Note C: Gouge root before welding second side.

Note J: If fillet welds are used in buildings to reinforce groove welds in corner and T-joints, they shall be equal to 1/4 T₁ but not exceed 3/8 in. (9.5 mm). The reinforcement of groove welds in corner joints, when required, shall be made with fillet welds equal to 1/4 T₁ but not more than 3/8 in. (9.5 mm).

Note M: Double-groove welds may have grooves of unequal depth, but the depth of the shallower groove shall be no less than one-fourth of the thickness of the thinner part joined.

Note V: For corner joints, the outside groove preparation may be in either or both members, provided the basic groove configuration is not changed and adequate edge distance is maintained to support the welding operations without excessive edge melting.

*F = Flat; OH = Overhead

Fig. 6 (continued)—Prequalified complete joint penetration groove welded

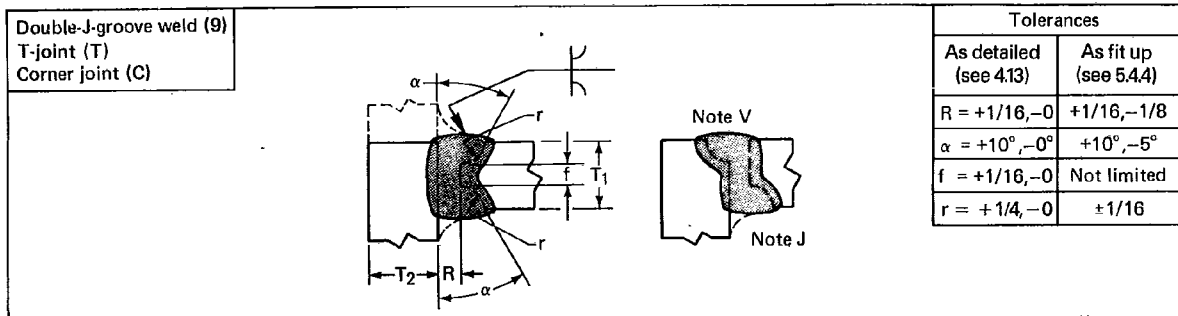

Tolerances	
As detailed (see 4.13)	As fit up (see 5.4.4)
$R = +1/16, -0$	$+1/16, -1/8$
$\alpha = +10^\circ, -0^\circ$	$+10^\circ, -5^\circ$
$f = +1/16, -0$	Not limited
$r = +1/4, -0$	$\pm 1/16$

Welding process	Joint designation	Base metal thickness (U = unlimited)		Groove preparation				Permitted welding positions	Gas shielding for (FCAW)	Notes
		T ₁	T ₂	Root opening	Groove angle	Root face	Groove radius			
SMAW	TC-U9a	U preferably 5/8 or thicker	U	$R = 0 \text{ to } 1/8$	$\alpha = 45^\circ$	$f = 1/8$	$r = 3/8$	All	-	C,J,M,V
				$R = 0 \text{ to } 1/8$	$\alpha = 30^\circ$	$f = 1/8$	$r = 3/8$	F,OH	-	C,J,M,V
GMAW FCAW	TC-U9a-GF	U preferably 5/8 or thicker	U	$R = 0 \text{ to } 1/8$	$\alpha = 30^\circ$	$f = 1/8$	$r = 3/8$	All	Not required	A,C,J,M,V

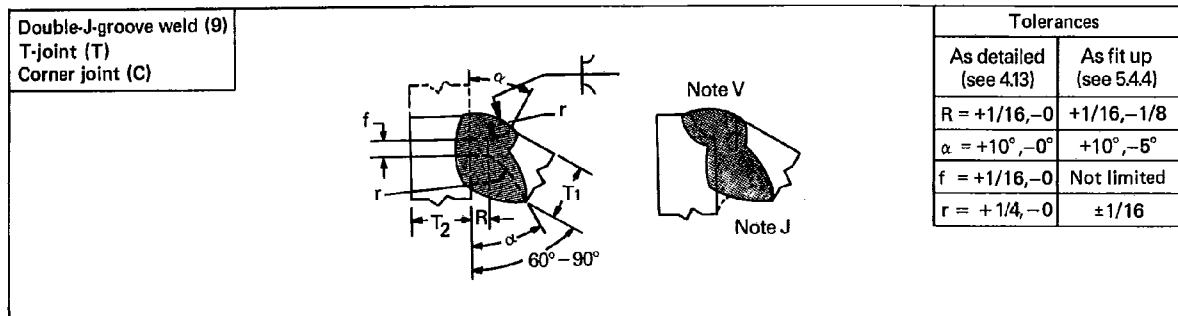

Tolerances	
As detailed (see 4.13)	As fit up (see 5.4.4)
$R = +1/16, -0$	$+1/16, -1/8$
$\alpha = +10^\circ, -0^\circ$	$+10^\circ, -5^\circ$
$f = +1/16, -0$	Not limited
$r = +1/4, -0$	$\pm 1/16$

Welding process	Joint designation	Base metal thickness (U = unlimited)		Groove preparation				Permitted welding positions*	Gas shielding for (FCAW)	Notes
		T ₁	T ₂	Root opening	Groove angle	Root face	Groove radius			
SMAW	TC-U9a	U preferably 5/8 or thicker	U	$R = 0 \text{ to } 1/8$	$\alpha = 45^\circ$	$f = 1/8$	$r = 3/8$	All	-	C,J,M,V
				$R = 0 \text{ to } 1/8$	$\alpha = 30^\circ$	$f = 1/8$	$r = 3/8$	F,OH	-	M,V
GMAW FCAW	TC-U9a-GF	U preferably 5/8 or thicker	U	$R = 0 \text{ to } 1/8$	$\alpha = 30^\circ$	$f = 1/8$	$r = 3/8$	All	Not required	A,C,J,M,V

- Note A: Not prequalified for gas metal arc welding using short circuiting transfer.
- Note C: Gouge root before welding other side.
- Note J: If fillet welds are used in buildings to reinforce groove welds in corner and T-joints, they shall be equal to 1/4 T₁ but not exceed 3/8 in. (9.5 mm). The reinforcement of groove welds in corner joints, when required, shall be made with fillet welds equal to 1/4 T₁ but not more than 3/8 in. (9.5 mm).
- Note M: Double-groove welds may have grooves of unequal depth, but the depth of the shallower groove shall be no less than one-fourth of the thickness of the thinner part joined.
- Note V: For corner joints, the outside groove preparation may be in either or both members, provided the basic groove configuration is not changed and adequate edge distance is maintained to support the welding operations without excessive edge melting.

*F = Flat, OH = Overhead

Fig. 6 (continued) - Prequalified complete joint penetration groove welded joints

30/SPECIFICATION FOR WELDING OF INDUSTRIAL & MILL CRANES

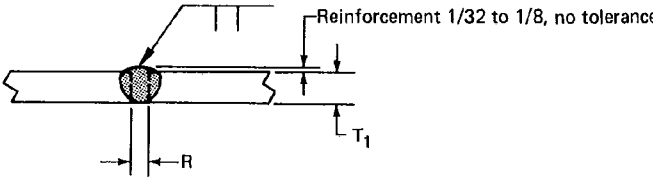
Square-groove weld (1) Butt joint (B)									
Welding process	Joint designation	Base metal thickness		Groove preparation			Permitted welding positions	Effective throat (E)	Notes
		(U = unlimited)		Root opening	Tolerances				
		T ₁	T ₂		As detailed (see 4.13)	As fit up (see 5.4.4)			
SMAW	B-P1a	1/8	-	R = 0 to 1/16	+1/16,-0	±1/16	All	T ₁ - 1/32	B,E
	B-P1c	1/4 max	-	R = $\frac{T_1}{2}$ min	+1/16,-0	±1/16 (see note D2)	All	$\frac{3T_1}{4}$	B,E

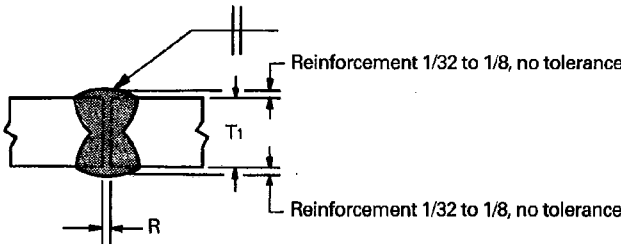
Square-groove weld (1) Butt joint (B)									
Welding process	Joint designation	Base metal thickness		Groove preparation			Permitted welding positions	Effective throat (E)	Notes
		(U = unlimited)		Root opening	Tolerances				
		T ₁	T ₂		As detailed (see 4.13)	As fit up (see 5.4.4)			
SMAW	B-P1b	1/4 max	-	R = 0 to 1/16	±0	+3/16 (See also Note D2)	All	$\frac{3T_1}{4}$	C2,E

Note B: Joints welded from one side.

Note C2: Root need not be gouged before welding other side.

Note D2: The parts to be joined by partial joint penetration groove welds parallel to the length of the member, bearing joints excepted, shall be brought into as close contact as practicable. The gap between parts shall not exceed 3/16 in. (4.8 mm) except in cases involving rolled shapes or plates 3 in. (76.2 mm) or greater in thickness if, after straightening and in assembly, the gap cannot be closed sufficiently to meet this tolerance. In such cases, a maximum gap of 5/16 in. (8.0 mm) is applicable, provided a sealing weld or suitable backing material is used to prevent melt-thru and the final weld meets the requirements for effective throat. Tolerances for bearing joints shall be in accordance with the applicable contract specifications.

Note E: Minimum effective throat as stated in Table 4.

Fig. 7—Prequalified partial joint penetration groove welded joints.

Welding process	Joint designation	Base metal thickness (U = unlimited)		Groove preparation			Permitted welding positions	Effective throat (E)	Notes
		T ₁	T ₂	Root opening Root face Groove angle	Tolerances				
					As detailed (see 4.13)	As fit up (see 5.4.4)			
SMAW	B-P2	1/2 max	-	R = 3/32 min f = 0 to 1/8 α = 60°	± 1/16 + 1/16 + 10°, - 0°	± 1/16 ± 1/16 + 10° - 5°	All	T ₁	B
SMAW	BC-P2	1/4 min	U	R = 0 f = 1/8 min α = 60°	± 0 ± 1/16 + 10°, - 0°	+ 1/16, - 0 ± 1/16 + 10°, - 5°	All	S	E
GMAW FCAW	BC-P2-GF	1/4 min	U	R = 0 f = 1/8 min α = 60°	± 0 ± 1/16 + 10°, - 0°	± 1/16, - 0 ± 1/16 + 10°, - 5°	All	S	A, E
SAW	BC-P2-S	7/16 min	U	R = 0 f = 1/4 min α = 60°	± 0 ± 1/16 + 10°, - 0°	+ 1/16, - 0 ± 1/16 + 10°, - 5°	Flat	S	E

Note A: Not prequalified for gas metal arc welding using short circuiting transfer.
 Note B: Joint is welded from one side only
 Note E: Minimum effective throat (E) as shown in Table 4, S is as specified on drawings.

Fig. 7 (continued)—Prequalified partial joint penetration groove welded joints

32/SPECIFICATION FOR WELDING OF INDUSTRIAL & MILL CRANES

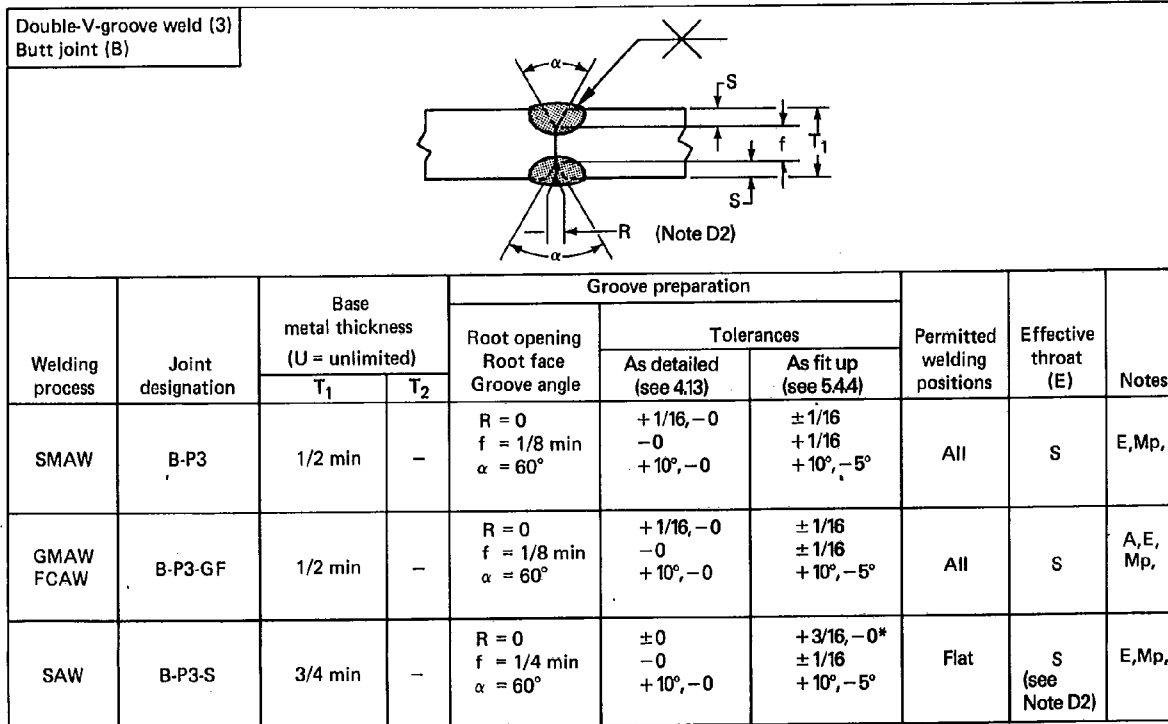

Note A: Not prequalified for gas metal arc welding using short circuiting transfer.

Note D2: The parts to be joined by partial joint penetration groove welds parallel to the length of the member, bearing joints excepted, shall be brought into as close contact as practicable. The gap between parts shall not exceed 3/16 in. (4.8 mm) except in cases involving rolled shapes or plates 3 in. (76.2 mm) or greater in thickness if, after straightening and in assembly, the gap cannot be closed sufficiently to meet this tolerance. In such cases, a maximum gap of 5/16 in. (8.0 mm) is applicable provided a sealing weld or suitable backing material is used to prevent melt-through and the final weld meets the requirements for effective throat. Tolerances for bearing joints shall be in accordance with the applicable contract specifications.

Note E: Minimum effective throat (E) as stated in Table 4; S as specified on drawings.

Note Mp: Double-groove welds may have grooves of unequal depth, provided they conform to the limitations of Note E. Also, the effective throat (E), less any reduction, applies individually to each groove.

*Fit-up tolerance, SAW: see Note D2; S for rolled shapes R may be 5/16 in. (8.0 mm) in thick plates if backing is provided.

Fig. 7 (continued)—Prequalified partial joint penetration groove welded joints

Welding process	Joint designation	Base metal thickness (U = unlimited)		Groove preparation			Permitted welding positions*	Effective throat (E)	Notes
		T ₁	T ₂	Root opening Root face Groove angle	Tolerances				
					As detailed (see 4.13)	As fit up (see 5.4.4)			
SMAW	BTC-P4	7/16 min (for bridges 1.2 min)	U	R = 0 f = 1/8 min α = 45°	+1/16, -0 -0 +10°, -0°	±1/16 ±1/16 +10°, -5°	All	S - 1/8	E,V
GMAW FCAW	BTC-P4-GF	1/4 min (for bridges 5/16 min)	U	R = 0 f = 1/8 min α = 45°	+1/16, -0 -0 +10°, -0°	±1/16 ±1/16 +10°, -5°	FH, V,OH	S S - 1/8	A,E,V
		7/16 min							
SAW	TC-P4-S	7/16 min (for bridges 1/2 min)	U	R = 0 f = 1/4 min α = 60°	±0 -0 +10°, -0dg	+3/16, -0*** ±1/16 +10°, -5°	Flat	S	E,V

Note A: Not prequalified for gas metal arc welding using short circuiting transfer.

Note D2: The parts to be joined by partial joint penetration groove welds parallel to the length of the member, bearing joints excepted, shall be brought into as close contact as practicable. The gap between parts shall not exceed 3/16 in. (4.8 mm) except in cases involving rolled shapes or plates 3 in. (76.2 mm) or greater in thickness if, after straightening and in assembly, the gap cannot be closed sufficiently to meet this tolerance. In such cases, a maximum gap of 5/16 in. (8.0 mm) is applicable provided a sealing weld or suitable backing material is used to prevent melt-through and the final weld meets the requirements for effective throat. Tolerances for bearing joints shall be in accordance with the applicable contract specifications.

Note E: Minimum effective throat as stated in Table 4; S as specified on drawings.

Note V: For corner joints, the outside groove preparation may be in either or both members, provided the basic groove configuration is not changed and adequate edge distance is maintained to support the welding operations without excessive edge melting.

*Fit-up tolerance, SAW: see Note D2; for rolled shapes R may be 5/16 in. (8.0 mm) in thick plates if backing is provided.

**Flat = Flat, H = Horizontal, V = Vertical, OH = Overhead

Fig. 7 (continued)—Prequalified partial joint penetration groove welded joints

34/SPECIFICATION FOR WELDING OF INDUSTRIAL & MILL CRANES

Double-bevel-groove weld (5) Butt joint (B) T-joint (T) Corner joint (C)									
Welding process	Joint designation	Base metal thickness (U = unlimited)		Groove preparation			Permitted welding positions*	Effective throat (E)	Notes
		T ₁	T ₂	Root opening Root face Groove angle	Tolerances				
					As detailed (see 4.13)	As fit up (see 5.4.4)			
SMAW	BTC-P5	3/4 min (for bridges 1/2 min)	U	R = 0 f = 1/8 min α = 45°	+ 1/16, -0 -0 + 10°, -0°	± 1/16 ± 1/16 + 10°, -5°	All	S - 1/8	E,MP
GMAW FCAW	BTC-P5-GF	1/2 min (for bridges 5/8 min)	U	R = 0 f = 1/8 min α = 45°	+ 1/16, -0 -0 + 10°, -0°	± 1/16 ± 1/16 + 10°, -5°	FH	S	A,E,MP
		3/4 min					V,OH	S - 1/8	
SAW	TC-P5-S	3/4 min (for bridges 7/8 min)	U	R = 0 f = 1/4 min α = 60°	± 0 -0 + 10°, -0°	+ 1/16, -0** ± 1/16 + 10°, -5°	Flat	S	E,MP

Note A: Not prequalified for gas metal arc welding using short circuiting transfer.

Note D2: The parts to be joined by partial joint penetration groove welds parallel to the length of the member, bearing joints excepted, shall be brought into as close contact as practicable. The gap between parts shall not exceed 3/16 in. (4.8 mm) except in cases involving rolled shapes or plates 3 in. (76.2 mm) or greater in thickness if, after straightening and in assembly, the gap cannot be closed sufficiently to meet this tolerance. In such cases, a maximum gap of 5/16 in. (8.0 mm) is applicable provided a sealing weld or suitable backing material is used to prevent melt-through and the final weld meets the requirements for effective throat. Tolerances for bearing joints shall be in accordance with the applicable contract specifications.

Note E: Minimum effective throat as stated in Table 4; S as specified on drawings.

Note Mp: Double-groove welds may have grooves of unequal depth, provided they conform to the limitations of Note E. Also, the effective throat (E), less any reduction, applies individually to each groove.

Note V: For corner joints, the outside groove preparation may be in either or both members, provided the basic groove configuration is not changed and adequate edge distance is maintained to support the welding operations without excessive edge melting.

* F = Flat, H = Horizontal

**Fit-up tolerance, SAW: see Note D2; for rolled shapes R may be 5/16 in. (8.0 mm) in thick plates if backing is provided.

Fig. 7 (continued)—Prequalified partial joint penetration groove welded joints

Single-U-groove weld (6) Butt joint (B) Corner joint (C)		Base metal thickness (U = unlimited)		Groove preparation			Permitted welding positions	Effective throat (E)	Notes
Welding process	Joint designation	T ₁	T ₂	Root opening Root face Groove radius Groove angle	Tolerances				
					As detailed (see 4.13)	As fit up (see 5.4.4)			
SMAW	BC-P6	1/4 min (for bridges 5/16 min)	U	R = 0 to 1/8 f = 1/8 min r = 1/4 α = 45°	+1/16, -0 -0 +1/4, -0 +10°, -0°	±1/16 ±1/16 ±1/16 +10°, -5°	All	S	E
GMAW FCAW	BC-P6-GF	1/4 min (for bridges 5/16 min)	U	R = 0 f = 1/8 min r = 1/4 α = 20°	+1/16, -0 -0 +1/4, -0 +10°, -0°	±1/16 +1/16 ±1/16 +10°, -5°	All	S	A,E
SAW	BC-P6-S	7/16 min (for bridges 1/2 min)	U	R = 0 f = 1/4 min r = 1/4 α = 20°	±0 -0 +1/4, -0° +10°, -0°	+3/16, -0* ±1/16 ±1/16 +10°, -5°	Flat	S	E

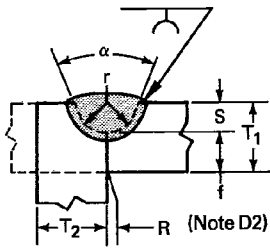

Note A: Not prequalified for gas metal arc welding using short circuiting transfer.

Note D2: The parts to be joined by partial joint penetration groove welds parallel to the length of the member, bearing joints excepted, shall be brought into as close contact as practicable. The gap between parts shall not exceed 3/16 in. (4.8 mm) except in cases involving rolled shapes or plates 3 in. (76.2 mm) or greater in thickness if, after straightening and in assembly, the gap cannot be closed sufficiently to meet this tolerance. In such cases, a maximum gap of 5/16 in. (8.0 mm) is applicable provided a sealing weld or suitable backing material is used to prevent melt-through and the final weld meets the requirements for effective throat. Tolerances for bearing joints shall be in accordance with the applicable contract specifications.

Note E: Minimum effective throat as stated in Table 4; S as specified on drawings.

*Fit-up tolerance, SAW: see Note D2; for rolled shapes R may be 5/16 in. (8.0 mm) in thick plates if backing is provided.

Fig. 7 (continued)—Prequalified partial joint penetration groove welded joints

36/SPECIFICATION FOR WELDING OF INDUSTRIAL & MILL CRANES

Double-U-groove weld (7) Butt Joint (B)									
Welding process	Joint designation	Base metal thickness (U = unlimited)		Groove preparation			Permitted welding positions	Effective throat (E)	Notes
		T ₁	T ₂	Root opening Root face Groove radius Groove angle	Tolerances				
					As detailed (see 4.13)	As fit up (see 5.4.4)			
SMAW	B-P7	1/2 min (for bridges 5/8 min)	—	R = 0 to 1/8 f = 1/8 min r = 1/4 α = 45°	+1/16, -0 -0 +1/4, -0 +10°, -0°	±1/16 ±1/16 +1/16 +10°, -0°	All	S	E, Mp
GMAW FCAW	B-P7-GF	1/2 min (for bridges 5/8 min)	—	R = 0 f = 1/8 min r = 1/4 α = 20°	+1/16, -0 -0 +1/4, -0 +10°, -0°	±1/16 ±1/16 ±1/16 +10°, -5°	All	S	A, E, Mp
SAW	B-P7-S	3/4 min (for bridges 7/8 min)	—	R = 0 f = 1/4 min r = 1/4 α = 20°	±0 -0 +1/4, -0 +10°, -0°	+3/16, -0* ±1/16 ±1/16 +10°, -5°	Flat	S	E, Mp

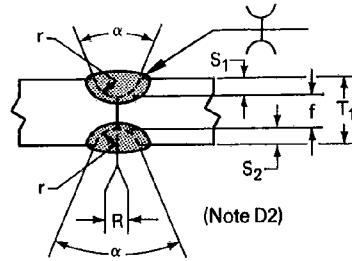

Note A: Not prequalified for gas metal arc welding using short circuiting transfer.

Note D2: The parts to be joined by partial joint penetration groove welds parallel to the length of the member, bearing joints excepted, shall be brought into as close contact as practicable. The gap between parts shall not exceed 3/16 in. (4.8 mm) except in cases involving rolled shapes or plates 3 in. (76.2 mm) or greater in thickness if, after straightening and in assembly, the gap cannot be closed sufficiently to meet this tolerance. In such cases, a maximum gap of 5/16 in. (8.0 mm) is applicable provided a sealing weld or suitable backing material is used to prevent melt-through and the final weld meets the requirements for effective throat. Tolerances for bearing joints shall be in accordance with the applicable contract specifications.

Note E: Minimum effective throat as stated in Table 4; S as specified on drawings.

Note Mp: Double-groove welds may have grooves of unequal depth, provided they conform to the limitations of Note E. Also, the effective throat (E), less any reduction applies individually to each groove.

*Fit-up tolerance, SAW: see Note D2; for rolled shapes R may be 5/16 in. (8.0 mm) in thick plates if backing is provided.

Fig. 7 (continued)—Prequalified partial joint penetration groove welded joints

Single-J-groove weld (B) Butt joint (B) T-joint (T) Corner joint (C)									
Welding process	Joint designation	Base metal thickness (U = unlimited)		Groove preparation			Permitted welding positions	Effective throat (E)	Notes
		T ₁	T ₂	Root opening Root face Groove radius Groove angle	Tolerances				
SMAW	BTC-P8	1/4 min (for bridges 5/16 min)	U	a = 45°	+10°, -0°	+10°, -5°	All	S	E,V
				R = 0 to 1/8 f = 1/8 min r = 3/8	+ 1/16, -0 -0 + 1/4, -0	± 1/16 ± 1/16 ± 1/16			
GMAW FCAW	BTC-P8-GF	1/4 min (for bridges 5/16 min)	U	a = 30°	+10°, -0°	+10°, -5°	All	S	A,E,V
				a = 20°	+10°, -0°	+10°, -5°			
SAW	C-P8-S	7/16 min (for bridges 1/2 min)	U	R = 0 f = 1/4 min r = 1/2	± 0 -0 + 1/4, -0	+ 3/16, -0** ± 1/16 ± 1/16	Flat	S	E,V
				a = 45°	+10°, -0°	+10°, -5°			
SAW	TP8-S	7/16 min	U				Flat	S	E

Note A: Not prequalified for gas metal arc welding using short circuiting transfer.

Note D2: The parts to be joined by partial joint penetration groove welds parallel to the length of the member, bearing joints excepted, shall be brought into as close contact as practicable. The gap between parts shall not exceed 3/16 in. (4.8 mm) except in cases involving rolled shapes or plates 3 in. (76.2 mm) or greater in thickness if, after straightening and in assembly, the gap cannot be closed sufficiently to meet this tolerance. In such cases, a maximum gap of 5/16 in. (8.0 mm) is applicable provided a sealing weld or suitable backing material is used to prevent melt-through and the final weld meets the requirements for effective throat. Tolerances for bearing joints shall be in accordance with the applicable contract specifications.

Note E: Minimum effective throat as stated in Table 4; S as specified on drawings.

Note V: For corner joints, the outside groove preparation may be in either or both members, provided the basic groove configuration is not changed and adequate edge distance is maintained to support the welding operations without excessive edge melting.

*Fit-up tolerance, SAW: see Note D2; for rolled shapes R may be 5/16 in. (8.0 mm) in thick plates if backing is provided.

Fig. 7 (continued)—Prequalified partial joint penetration groove welded joints

38/SPECIFICATION FOR WELDING OF INDUSTRIAL & MILL CRANES

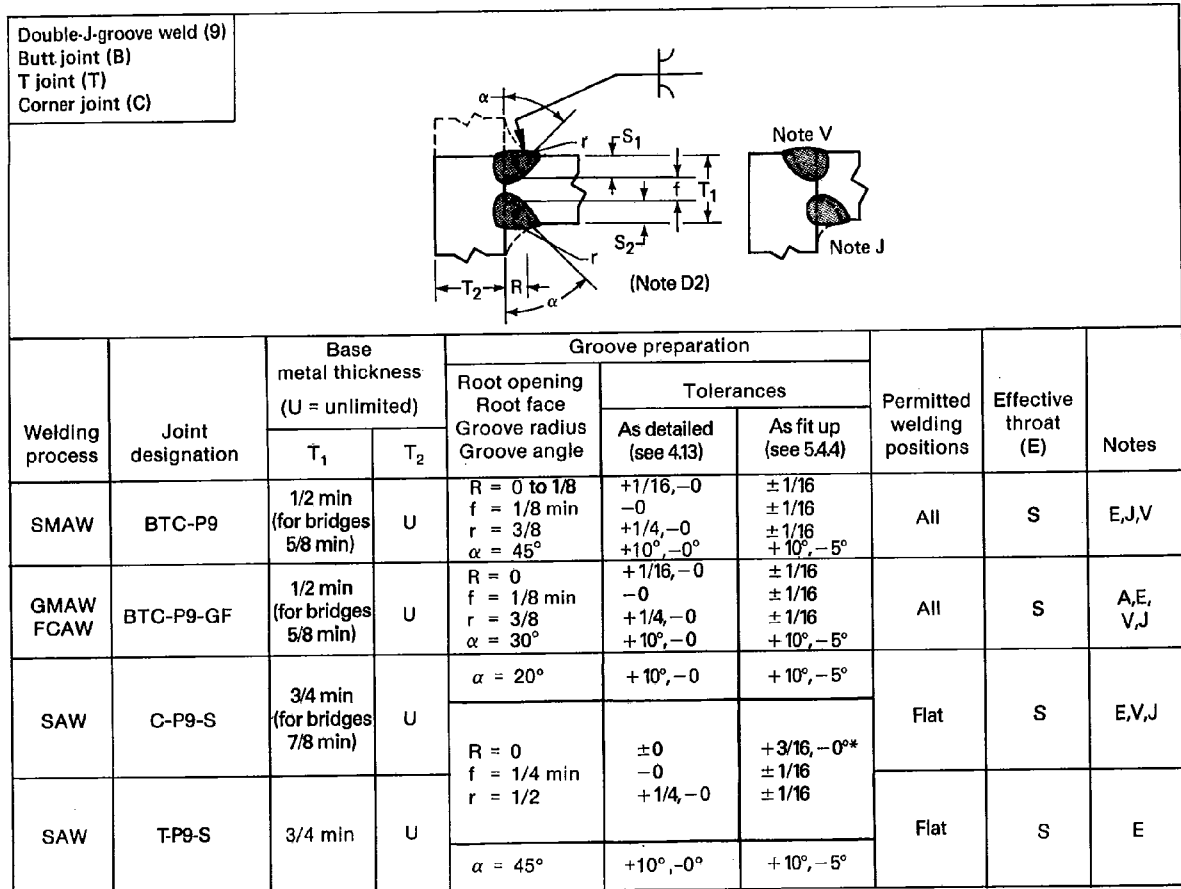

Note A: Not prequalified for gas metal arc welding using short circuiting transfer.

Note D2: The parts to be joined by partial joint penetration groove welds parallel to the length of the member, bearing joints excepted, shall be brought into as close contact as practicable. The gap between parts shall not exceed 3/16 in. (4.8 mm) except in cases involving rolled shapes or plates 3 in. (76.2 mm) or greater in thickness if, after straightening and in assembly, the gap cannot be closed sufficiently to meet this tolerance. In such cases, a maximum gap of 5/16 in. (8.0 mm) is applicable provided a sealing weld or suitable backing material is used to prevent melt-through and the final weld meets the requirements for effective throat. Tolerances for bearing joints shall be in accordance with the applicable contract specifications.

Note E: Minimum effective throat as stated in Table 4; S as specified on drawings.

Note J: If fillet welds are used in buildings to reinforce groove welds in corner and T-joints, they shall be equal to 1/4 T₁ but not exceed 3/8 in. (9.5 mm). The reinforcement of groove welds in corner joints, when required, shall be made with fillet welds equal to 1/4 T₁ but not more than 3/8 in. (9.5 mm).

*Fit-up tolerance, SAW: see Note D2; for rolled shapes R may be 5/16 in. (8.0 mm) in thick plates if backing is provided.

Fig. 7 (continued)—Prequalified partial joint penetration groove welded joints

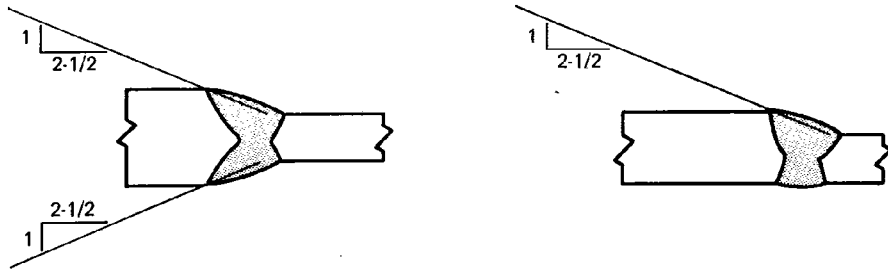

Transition by sloping weld surface

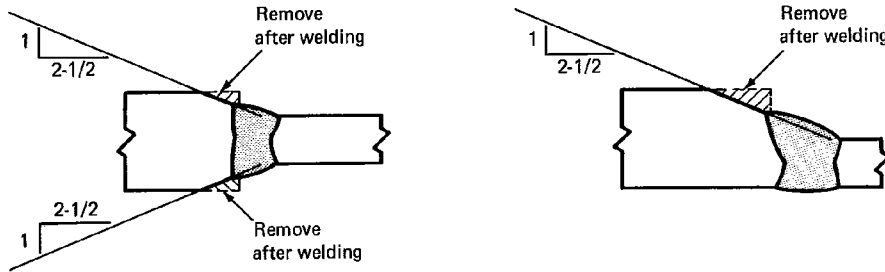

Transition by sloping weld surface and chamfering

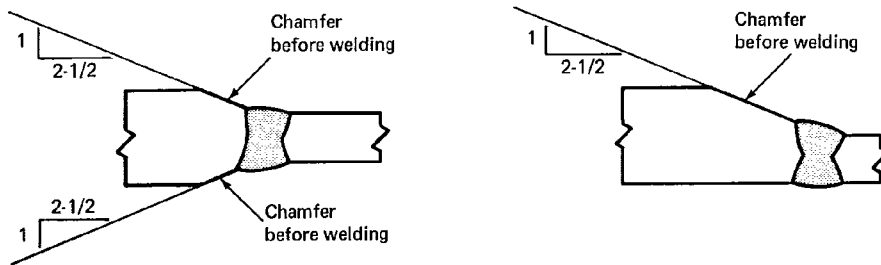

Transition by chamfering thicker part

Center line alignment
(particularly applicable to web plates)

Offset alignment
(particularly applicable to flange plates)

Notes:

1. Groove may be of any permitted or qualified type and detail.
2. Transition slopes shown are the maximum permitted.

Fig. 8—Transition of butt joints in parts of unequal thickness

40/SPECIFICATION FOR WELDING OF INDUSTRIAL & MILL CRANES

with the edge of either part or (2) a 2.0 ft (610 mm) minimum radius tangent to the narrower part at the center of the butt joint, as shown in Fig. 9.

4.12 Prequalified Extension Bars, Runoff Plates, and Backing Materials

4.12.1 Extension bars and runoff plates used in welding shall conform to the following requirements:

(1) When used for welding any approved steel listed in 2.3, they may be of any of the steels in the same list.

(2) When used for welding with a steel qualified in accordance with this specification, they may be either the steel qualified or any steel listed in 2.3.

4.12.2 Steel backing shall conform to the requirements of 4.12.1, except that a backing of 100 ksi (689 MPa) minimum yield strength steel shall only be used with a steel of the same minimum yield strength.

4.12.3 Spacers shall be of the same material as the base metal.

4.13 Dimensional Tolerances. Dimensions of groove welds specified on design or detailed drawings may vary from the dimensions shown in Figs. 6 and 7 only within the following limits:

4.13.1 The specified thickness of base metal or weld effective throat is the maximum nominal thickness that may be used.

4.13.2 The groove angle is minimum; it may be detailed to exceed the dimensions shown by no more than 10 degrees.

4.13.3 The radius of J- and U-grooves is minimum. It may be detailed to exceed the dimensions shown by no more than 1/8 in. (3 mm). U-groove may be prepared before or after fit-up.

4.13.4 Double-groove welds may have grooves of unequal depth, but the depth of the shallower groove shall be no less than 1/4 of the thickness of the thinner part joined, unless otherwise designated in Figs. 6 and 7.

4.13.5 The root face of the joint shall be as shown in Figs. 6 and 7 with the following variations permitted:

(1) For shielded metal arc, gas metal arc, and flux cored arc welding, it may be detailed to exceed the specified dimension by not more than 1/16 in. (1.6 mm). It may not be detailed less than the specified dimension.

(2) For submerged arc welding, the specified root face of the joint is maximum.

4.13.6 The root opening of the joints is minimum. It may be detailed to exceed the specified dimensions by no more than 1/16 in. (1.6 mm), except that the root opening of joints for submerged arc weld shall be detailed as zero (no variation) when so specified.

5. Workmanship

5.1 General

5.1.1 All requirements of this section shall be observed in the production and inspection of welded assemblies produced by any of the processes acceptable under this specification.

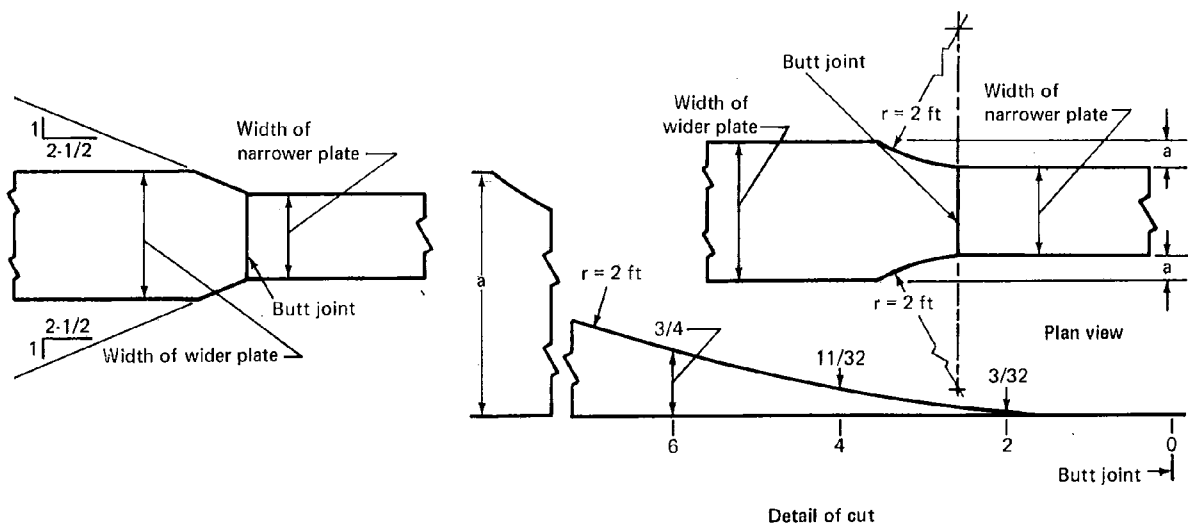

Fig. 9—Transition of width at butt joints of parts having unequal width

5.1.2 All items of equipment for welding and torch cutting shall be (1) designed and manufactured and (2) be in proper condition to enable qualified welders, welding operators, and tack welders to follow the procedures and attain the results prescribed elsewhere in this specification.

5.1.3 Welding shall not be done when (1) the temperature of the part to be welded is lower than that specified on engineering drawings, in applicable welding procedures, or (2) the surfaces are wet or exposed to rain, snow, or winds of sufficient velocity to disrupt the protection of the welding atmosphere. The maximum permissible wind velocity will vary with the welding process and procedure. Heating, local protection from the elements, or both, shall be used as necessary.

5.1.4 The size and length of welds shall not be less than those specified by design requirements and detail drawings, nor shall they exceed those requirements by more than 25 percent without prior approval of the design engineer. Also, the location of welds shall not be changed without prior approval of the design engineer.

5.1.5 Arc strikes outside of the area of permanent welds shall be avoided on any base metal. Arc strikes or temporary welds in critical areas, as defined by the design engineer, shall be ground to a smooth contour and inspected to insure soundness by an appropriate nondestructive test method, such as dye penetrant or magnetic particle.

5.2 Preparation of the Base Metal

5.2.1 Surface and edges to be welded shall be smooth, uniform, and free from fins, tears, cracks, and other visual defects that would adversely affect the quality of the weld. Surfaces to be welded and surfaces adjacent to a weld shall also be free from loose or thick mill scale, slag, rust, paint, moisture, and other foreign material, or contaminants that will prevent proper welding or produce hazardous fumes. Thin mill scale (that can withstand vigorous wire brushing), thin rust-inhibitive coating, or anti-spatter compound (that will not cause problems with welding) need not be removed.

5.2.2 When oxygen cutting, the cutting torch shall be adjusted and manipulated to avoid cutting beyond (inside) the prescribed lines. The roughness of oxygen-cut surfaces shall not be greater than Sample No. 2 of AWS C4.1, *Surface Roughness Gauge*, for material thicknesses up to 2 in. (51 mm), and Sample No. 1 for material 2 in. (51 mm) to 8 in. (203 mm) thick. Surfaces exceeding the above roughness values, and occasional notches or gouges not exceeding 3/16 in. (5 mm) deep, shall be corrected by machining or grinding. Notches or other sharp discontinuities exceeding 3/16 in. (5 mm) may be repaired by welding only with the approval of the design engineer. Approval weld repairs shall be made only by following a documented repair welding procedure that shall contain the following:

(1) Discontinuity preparation.

(2) Welding process and filler metal to be used.

(3) Preheat and welding variables and also any post heat requirements necessary to comply with this specification.

(4) Procedures for grinding the completed weld smooth and flush to within the surface roughness acceptance criteria of an oxygen-cut surface. Weld repaired surfaces and edges, that will not be subsequently incorporated into a welded joint, shall be stress-relieved by any approved method when determined necessary by the design engineer.

5.2.3 Machining, plasma arc cutting, air-carbon cutting, oxygen cutting, oxygen gouging, chipping, or grinding may be used for joint preparation, back gouging, and the removal of unacceptable work or metal. One exception is that oxygen gouging shall not be used on quenched-and-tempered steel. Air-carbon arc cut surfaces should be ground to bright metal.

5.2.4 Edges of built-up beam and girder webs shall be cut to the prescribed camber with empirically developed manufacturing allowance for shrinkage due to cutting and welding. However, deviation from the specified camber tolerances may be corrected by carefully supervised application of a limited amount of localized heat or other suitable means of obtaining the specified camber.

The use of flame straightening of distorted members and camber correction by localized heating must have the approval of the design engineer. When flame straightening is used, the temperature of the heated areas shall be accurately measured. The temperature shall not exceed 1100° F (590° C) for quenched-and-tempered steels, and 1600° F (890° C) for all other steels.

5.2.5 Dimensional Tolerances. Dimensions of built-up beams and girders shall be within the tolerance of the general specification governing the work, and also within the following special tolerances. All measurements shall be taken at the manufacturer's plant prior to shipment, unless otherwise specified.

5.2.5.1 Maximum deviation from straightness, D_S , (referenced to the neutral axis) of welded beams or girders, where there is no specified sweep:

$$D_S, \text{ in.} = 0.0125 \times \text{total length, ft}$$

$$D_S, \text{ mm} = 0.9 \times \text{total length, m}$$

5.2.5.2 Maximum deviation from specified camber, D_C , of welded beam or girders:

$$D_C, \text{ in.} = + 0.003 \times \text{total length, ft, or } \pm 1/4 \text{ in., whichever is greater}$$

$$D_C, \text{ mm} = \pm 0.024 \times \text{total length, m, or } \pm 6 \text{ mm, whichever is greater}$$

5.2.5.3 Lateral deviation between the center line of the web and the center line of the flange of builtup H or I members at the contact surface (referenced to neutral axis) shall be 1/4 in. (6 mm) maximum.

42/SPECIFICATION FOR WELDING OF INDUSTRIAL & MILL CRANES

5.2.5.4 The maximum deviation from the specified depth for welded built-up beams and girders, measured at the web center line, shall be $\pm 1/2$ in. (± 13 mm) for depths up to 72 in. (1.8 m). For depths over 72 in. (1.8 m), the maximum deviation shall be $+ 3/4$ to $- 1/2$ in. ($+ 19$ to $- 13$ mm).

5.2.6 Re-entrant corners except for the corners of weld access cope holes adjacent to a flange, shall be filleted to a radius of no less than $3/4$ in. (19 mm). The fillet and its adjacent cuts shall meet without offset or cutting past the point of tangency.

5.3 Visual Inspection and Repair of Plate and Wrought Steel Products

5.3.1 In the repair and the determination of the limits of visible internal discontinuities on rolled, sheared, or oxygen-cut edges, the amount of metal removed shall be the minimum necessary to remove the discontinuity, but not to exceed the permissible limit given in Table 6. Plate cut edges may exist at any angle with respect to the rolling direction. All repairs of discontinuities by welding shall conform to the applicable provision of this specification.

5.3.2 The limits of acceptability and the repair of visually observed edge discontinuities shall be in accordance with Table 6. The length of discontinuity is the visible length dimension on the plate edge, and the depth is

the distance that the discontinuity extends into the plate from the edge.

5.3.3 Discontinuities over 1 in. (25 mm) in length and in depth, when discovered during either visual inspection of plate edges or nondestructive examination of welded joints, shall be evaluated further. The following procedures are recommended:

(1) Where discontinuities, such as W, X, or Y in Fig. 10 are observed prior to completing the joint, the size and shape of the discontinuity shall be determined by ultrasonic inspection. The area of the discontinuity shall be determined as the area of total loss of back reflection when tested in accordance with the procedures of ASTM A435.

(2) For acceptance, the area of a single discontinuity or the aggregate area of multiple discontinuities shall not exceed 4 percent of the plate area (length x width) with the following exception. If the width of a single discontinuity or the aggregate width of discontinuities on any transverse section, as measured perpendicular to the plate length, exceeds 20 percent of the plate width, the maximum allowable area shall be reduced by the percentage amount of the width exceeding 20 percent. For example, if a discontinuity is 30 percent of the plate width, the percentage area of discontinuity cannot exceed 4 minus 4 times (0.30-0.20), or 3.6 percent of the plate area. The discontinuity on the edge of the plate shall be gouged out to a depth of 1 in. (25 mm) beyond its intersection with

Table 6
Limits on acceptability and repair of
edge discontinuities in plate

Size of discontinuity		
Length, in. (mm)	Depth, in. (mm)	Repair required
1 (25) or less	Unspecified	None; need not be explored
Over 1 (25)	1/8 (3) max	None; depth should be explored per Note 1.
Over 1 (25)	Over 1/8 (3) to 1/4 (6)	Remove; repair welding not required.
Over 1 (25)	Over 1/4 (6) to 1 (25)	Completely remove and repair weld as limited by Note 2.
Over 1 (25)	Over 1 (25)	Refer to 5.3.3

Notes:

(1) A spot check of 10 percent of the discontinuities on the edge in question should be explored by grinding to determine depth. If the depth of any one of the discontinuities explored exceeds 1/8 in. (3 mm), then all of the discontinuities remaining on that edge shall be explored by grinding to determine depth. If none of the discontinuities explored in the 10 percent spot check has a depth exceeding 1/8 in. (3 mm), then the remainder of discontinuities on that edge need not be explored.

(2) Aggregate length of welding shall not exceed 20 percent of the length of the plate edge being repaired.

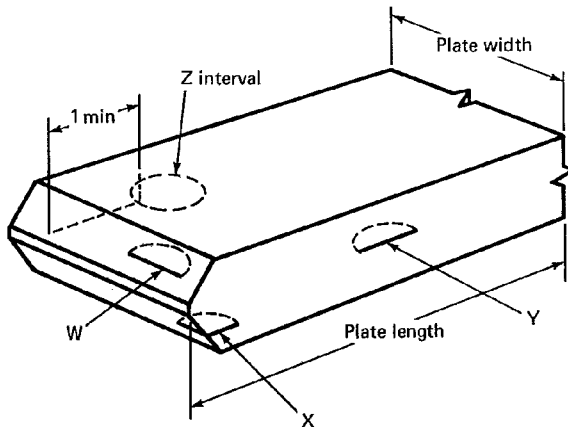

Fig. 10—Edge discontinuities in cut plate

the surface by chipping, air-carbon arc gouging, or grinding, and then blocked off by welding in layers not exceeding 1/8 in. (3 mm) in thickness.

(3) Repair of an internal discontinuity, Z, in Fig. 10 is not required if it does not exceed the allowable area in 5.3.3(2), is discovered after the joint has been completed, and is 1 in. (25 mm) or more from the toe of the weld as measured on the plate surface. Type Z discontinuity is less than 1 in. (25 mm) from the toe of the weld, it shall be gouged out to a distance of 1 in. (25 mm) from the weld metal. It shall then be blocked by welding in layers not exceeding 1/8 in. (3 mm) in thickness.

(4) If the area of a discontinuity W, X, Y, or Z exceeds the allowable in 5.3.3(2), the plate or subcomponent shall be either rejected and replaced or repaired at the discretion of the design engineer.

(5) The aggregate length of weld repair shall not exceed 30 percent of the length of the plate edge without approval of the design engineer.

(6) All repairs shall be in accordance with this specification. Gouging of a discontinuity may be done from either the plate surface or the edge.

5.4 Assembly

5.4.1 Parts to be joined by fillet welds shall be brought as close together as practicable at the joint. Root cracking may occur in a fillet weld if there is no root opening between the parts. Therefore, it may be necessary to provide a root opening of about 1/32 in. (0.8 mm) prior to welding. The root opening between parts shall not exceed 1/8 in. (3 mm) for sections up to 2 in. (51 mm) in thickness. When the root opening between shapes or plates of 2 in. (51 mm) or more in thickness cannot be closed to meet this tolerance, a maximum root opening of 3/16 in.

(5 mm) is acceptable if a sealing weld or suitable backing material¹¹ is used to prevent melt-thru. If the root opening is 1/16 in. (1.6 mm) or greater, the leg of the fillet weld shall be increased by the amount of the separation, or the contractor shall demonstrate that the required effective throat has been obtained.

The separation between the faying surfaces of lap joints and butt joints with a backing shall not exceed 1/16 in. (1.6 mm). Deviations from these limits must be approved by the design engineer.

5.4.2 Parts to be joined by partial-joint-penetration groove welds parallel to the length of the member (bearing joints excepted) shall be brought as close together as practicable. The root opening between parts shall not exceed 1/8 in. (3 mm). If the root opening between rolled shapes or plates of 2 in. (51 mm) or greater in thickness cannot be closed sufficiently to meet this tolerance, a maximum gap of 3/16 in. (5 mm) is acceptable provided (1) a sealing welding or suitable backing material is used to prevent melt-thru and (2) the final weld meets the requirements for effective throat. Tolerances for bearing joints shall be in accordance with the applicable contract specification or the manufacturer's standard if no tolerances are included in the contract. Deviations from these limits must be approved by the design engineer.

5.4.3 Abutting parts to be joined by groove welds shall be carefully aligned. Where the parts are effectively restrained against bending due to eccentricity in alignment, and offset not exceeding 10 percent of the thickness of the thinner part joined, but in no case more than 0.18 in. (4.5 mm), may be permitted as a departure from the theoretical alignment. In correcting misalignment in such cases, the slope of the drawn-in parts shall not exceed 1 to 24. Measurement of offset shall be based upon center line of parts, unless otherwise shown on the drawing. Deviations from these limits shall be approved by the design engineer.

5.4.4 Dimensions of the cross section of groove weld joint preparations that vary from those shown on the detail drawings by more than the tolerances given in Table 7 shall be referred to the design engineer for acceptance. Exceptions are grooves for electroslag and electrogas welds.

5.4.5 Grooves produced by gouging shall be in accordance with the requirements for processes and filler metals of Section 6.

5.4.6 Groove welds shall be terminated at the ends of a joint in a manner that will ensure sound welds. This should be done by use of extension bars or run-off plates.

¹¹ Backing to prevent melting-thru may be flux, glass tape, iron powder, or similar materials. Sealant (root) passes should be with low-hydrogen covered electrodes or other arc welding processes.

44/SPECIFICATION FOR WELDING OF INDUSTRIAL & MILL CRANES

Table 7
Tolerances for groove weld joint preparations
for arc welding

	Root not gouged		Root gouged	
	in.	mm	in.	mm
Root face	± 1/16	± 1.6	Not limited	
Root opening with other than steel backing	± 1/16	± 1.6	+ 1/16	+ 1.6
Root opening with steel backing	+ 1/4	+ 6	Not applicable	
Groove angle	+ 5°		+ 10°	- 5°

5.4.7 Extension bars and run-off plates shall be removed upon completion of the welding, and the ends of the weld shall be finished smooth and flush with the edges of the abutting parts.

5.4.8 The weld metal of groove welds made with steel backing strips shall be thoroughly fused with the backing. Steel backings shall be removed, where accessible, from welds that either are subjected to computed stress or are part of the structure, and the joints shall be ground or finished smooth.

5.4.9 Members to be welded shall be brought into correct alignment and held in position by clamps, wedges, guy lines, struts, tack welds, or other suitable devices until welding has been completed. The use of jigs and fixtures is recommended where practicable. Suitable allowances shall be made for warpage and shrinkage.

5.4.10 Steel backing strip shall be continuous for the full length of a weld. Welded butt joints in a fabricated steel backing strip shall have complete joint penetration, and the joints shall be welded prior to placement of the strip.

5.4.11 Caulking over welds is not permitted.

5.5 Control of Distortion and Shrinkage Stresses

5.5.1 The procedure and welding sequence for assembling and joining parts of a structure or of built-up members and for welding reinforcing parts to members shall be designed to minimize distortion and shrinkage.

5.5.2 All welds, insofar as practicable, shall be deposited in a sequence that will balance the applied heat while welding progresses.

5.5.3 A program for welding sequence and distortion control shall be provided where shrinkage stresses or distortion are likely to affect the adequacy of the structure.

5.5.4 Joints that are expected to produce large shrinkage should usually be welded with as little restraint as pos-

sible before other joints that are expected to cause less shrinkage are welded.

5.6 Stress Relief

5.6.1 All required stress relieving shall be covered by a written procedure.

5.6.2 Localized stress relieving may be employed, subject to approval by the design engineer, when it is impractical to stress relieve the entire weldment. A written procedure must address the variables given in 5.6.3.

5.6.3 The procedures for furnace stress relief must address the following:

- (1) Temperature at the start of the thermal cycle
- (2) Rate of heating to temperature
- (3) Maximum allowable variation of temperature throughout the portion of the part being heated
- (4) Maximum temperature tolerance at stress relief temperature
- (5) Holding time at stress relief temperature
- (6) Rate of cooling to a temperature suitable for removal of work from the furnace
- (7) Location and number of thermocouples required

5.7 Vibratory Conditioning

5.7.1 Vibratory conditioning may be used at the option of the manufacturer to improve dimensional stability. The conditioning shall be done in accordance with the recommendations of the manufacturer of the vibratory equipment.

5.7.2 The conditioning process shall be covered by a written procedure.

5.8 Studs

5.8.1 Studs shall be welded to steel members with automatically timed, stud welding equipment. Welding current, time, and gun settings for lift and plunge should be

based on past practice, recommendations of the study or the equipment manufacturer, or both. AWS C5.4, *Recommended Practices for Stud Welding*, latest edition, should also be followed.

5.8.2 If two or more stud welding guns are to be operated from the same power source, they shall be interlocked to prevent simultaneous operation and to permit the power source to fully recover between welds.

5.8.3 While in operation, the welding gun shall be held in welding position without movement until the weld metal has solidified.

5.8.4 At the time of welding, the studs shall be free from rust, rust pits, scale, oil, or other deleterious matter that would adversely affect the welding operation.

5.8.5 The stud base shall be painted, galvanized, or cadmium plated prior to welding.

5.8.6 The areas on the member to which the studs are to be welded shall be free of scale, rust, or other injurious material to the extent necessary to obtain satisfactory welds. These areas may be cleaned by wire brushing, shot or sand blasting, prick-punching, grinding, or other suitable means.

5.8.7 Welding shall not be done when the base metal temperature is below 50° F (10° C), or when the surface is wet.

5.8.8 After welding, arc shield ferrules shall be broken free from the studs, and the welds visually inspected. Each weld shall have a full 360 degree flash.

5.8.9 The studs, after welding, shall be free of any discontinuities or other defects in the flash. Nonfusion on the legs of the flash and small fissures are acceptable.

6. Processes and Filler Metals

6.1 General

6.1.1 Filler Metal Requirements

6.1.1.1 The electrode, electrode-flux combination, or other filler metal for making complete-joint-penetration groove welds shall be in accordance with Table 8 when matching weld metal is required by Table 2.

6.1.1.2 The electrode, electrode-flux combination, or other filler metal for complete-joint-penetration or partial-joint-penetration groove welds and for fillet welds may provide lower strength weld metal, as permitted in Table 2. The allowable stress in the weld metal shall not exceed that allowed in the table.

6.1.2 Preheat and Interpass Temperature Requirements. Preheat and interpass temperatures shall be in accordance with Table 9 for the welding process being used, and for the higher strength base metals being welded. For stud welding, see 5.8.7

6.1.3 Heat Input Control for Quenched-and-Tempered Steel. When quenched-and-tempered steels are welded, the heat input shall be restricted in conjunction

Table 8
Matching filler metal requirements for prequalified complete-joint-penetration groove welds

Base metal (a)	Welding process			
	SMAW	SAW	GMAW	FCAW
Class I and II	AWS A5.1 or A5.5, E6XX or E7XX	AWS A5.17 or A5.12, F6XX or EXXX or F7XX-EXXX	AWS A5.18, ER70X-X	AWS A5.20, E6XT-X or E7XT-X (except -2, ^(b) -3, -10, -GS)
Class III	AWS A5.1 or A5.5, E7XX ^(c)	AWS A5.17 or A5.23, F7XX-EXXX	AWS A5.18, ER70X-X	AWS A5.20, E7XT-X (Except -2, ^(b) -3, -10, -GS)
Class IV ^(d)	AWS A5.5, E8XX ^(c)	AWS A5.23, F8XX-EXXX	AWS A5.28, ER80S-X	AWS A5.29, E8XTX-X
Class V ^(d)	AWS A5.5, E11XXX	AWS A5.23, F11XX-EXXX	AWS A5.28, ER110S-X	AWS A5.29, E11XTX-X

Note: The use of the same type of filler metal having the next higher mechanical properties, as listed in the applicable AWS specification, is permitted.

(a) In joints involving base metals of different yield points or strengths, filler metals applicable to the lower strength base metal may be used, except that low-hydrogen electrodes shall be used if they are normally required for either base metal.

(b) If EXXX-2 electrodes are used on successfully tested prototype vehicles, this qualified the use of such electrodes for production.

(c) Low-hydrogen classification only.

(d) When welds are to be thermally stress relieved, the deposited weld metal shall not exceed 0.05% vanadium.

46/SPECIFICATION FOR WELDING OF INDUSTRIAL & MILL CRANES

Table 9
Minimum preheat and interpass temperature^(c)

Weldability classification of base metal	Welding process	Thickness of thickest part at point of welding		Minimum temperature ^{(a),(b)}	
		in.	mm	°F	°C
I	Shielded metal arc welding with other than low hydrogen electrodes	Up to 3/4	19 incl.	None ^(a)	
		Over 3/4 thru 1-1/2	19 38 incl.	None ^(a)	
		Over 1-1/2 thru 2-1/2	38 64	50	10
		Over 2-1/2	64	200	95
I	Shielded metal arc welding with low hydrogen electrodes, submerged arc welding, gas metal arc welding, flux- cored arc welding.	Up to 3/4	19 incl.	None ^(a)	
		Over 3/4 thru 1-1/2	19 64 incl.	None ^(a)	
		Over 1-1/2 thru 2-1/2	38 64 incl.	None ^(a)	
		Over 2-1/2	64	150	66
II	Shielded metal arc welding with other than low hydrogen electrodes	Up to 3/4	19 incl.	None ^(a)	
		Over 3/4 thru 1-1/2	19 38 incl.	150	66
		Over 1-1/2 thru 2-1/2	38 64	225	107
		Over 2-1/2	64	300	150
II & III	Shielded metal welding with low hydrogen electrodes, submerged arc welding, gas metal arc welding, flux cored arc welding	Over 3/4	19 incl.	None ^(a)	
		Over 3/4 thru 1-1/2	19 38 incl.	50	10
		Over 1-1/2 thru 2-1/2	38 64 incl.	150	66
		Over 2-1/2	64	225	107

(Continued)

Table 9 (continued)

Weldability classification of base metal	Welding process	Thickness of thickest part at point of welding		Minimum temperature ^{(a),(b)}	
		in.	mm	°F	°C
I	Shielded metal arc welding with low hydrogen electrodes, submerged arc welding, gas metal arc welding, flux cored arc welding	Up to 3/4	19 incl.	50	10
		Over 3/4 thru 1-1/2	19 38 incl.	150	66
		Over 1-1/2 thru 2-1/2	38 64	225	107
		Over 2-1/2	64	300	150
V	Shielded metal arc welding with low hydrogen electrodes, submerged arc welding, with carbon or alloy steel wire, neutral or active flux ^(c) gas metal arc welding, flux cored arc weld- ing	Up to 3/4	19 incl.	50	10
		Over 3/4 thru 1-1/2	19 38 incl.	125	50
		Over 1-1/2 thru 2-1/2	38 64 incl.	175	80
		Over 2-1/2	64	225	107
V	Submerged arc welding with carbon steel wire, alloy flux ^(c)	Up to 3/4	19 incl.	50	10
		Over 3/4 thru 1-1/2	19 38 incl.	200	95
		Over 1-1/2 thru 2-1/2	38 64	300	150
		Over 2-1/2	64	400	205

(a) When the base metal temperature is below 32° F (0° C), the base metal shall be preheated to at least 70° F (21° C) for a distance equal to the thickness of the part being welded, but not less than 3 in. (75 mm) both laterally and in advance of welding. This minimum temperature shall be maintained during welding. Preheat and interpass temperature must be sufficient to prevent crack formation. Temperature above the minimum shown may be required for highly restrained welds. For quenched and tempered steel, the maximum preheat and interpass temperature should not exceed 400° F (250° C) for thicknesses up to 1-1/2 in. (32 mm) inclusive or 450° F (230° C) for greater thicknesses. When welding quenched and tempered steel, heat input should not exceed the steel producer's recommendation.

(b) In joints involving combinations of base metals, preheat shall be as specified for the higher strength steel being welded.

(c) Neutral flux: flux whose primary purpose is to shield the weld metal.

Active flux: flux whose primary purpose is to deoxidize the weld metal.

Alloy flux: flux whose primary purpose is to alloy the weld metal.

48/SPECIFICATION FOR WELDING OF INDUSTRIAL & MILL CRANES

with the maximum preheat and interpass temperatures permitted for the metal thickness. The heat input limitations shall be in accordance with the steel producer's recommendations. The use of stringer beads to avoid overheating is strongly recommended. Oxygen gouging of quenched-and-tempered steel is not permitted.

6.1.4 Backing for Groove Welds. Materials used for backing of groove welds may be steel, neutral submerged arc welding flux, nonfusible backup bars, or commercially available tapes made specifically for this purpose. The backing material employed shall not alter the weld metal composition, and the joints shall meet the requirements of Section 4.

6.2 Shielded Metal Arc Welding

6.2.1 Electrodes for Shielded Metal Arc Welding

6.2.1.1 Electrodes for shielded metal arc welding shall conform to the requirements of the latest edition of either AWS A5.1, *Specification for Covered Carbon Steel Arc Welding Electrodes*, or AWS A5.5, *Specification for Low Alloy Steel Covered Arc Welding Electrodes*, whichever is applicable.

6.2.1.2 All electrodes having low-hydrogen coverings conforming to AWS A5.1 shall be purchased in hermetically-sealed containers, or shall be dried for at least 2 hours at between 450° F (232° C) and 500° F (260° C) before being used. Electrodes having low-hydrogen coverings conforming to AWS A5.5 shall be purchased in hermetically-sealed containers, or shall be dried for at least 1 hour at a temperature of between 700° F (370° C) and 800° F (427° C) before being used, in accordance with the recommendations in the Appendix of AWS A5.5. Electrodes shall be dried prior to use if the hermetically-sealed container shows evidence of damage.

Immediately after opening of hermetically-sealed containers or removal from drying ovens, the electrodes shall be consumed or stored in ovens held at a temperature of at least 250° F (120° C). E70XX electrodes that are not used within 4 hours, E80XX within 2 hours, E90XX within 1 hour, and E110XX within 1/2 hour after removal from hermetically-sealed containers or from a drying or storage oven shall be redried before use. Electrodes shall be redried not more than one time. Electrodes that are or have been wet shall not be used.

6.2.1.3 The classification and size of electrode, arc length, voltage and amperage shall be suited to the thickness of the base metal, type of groove, welding position, and other circumstances attending the work.

6.2.1.4 The maximum size of electrodes shall be as follows:

- (1) 5/16 in. (8 mm) for all welds made in the flat position, except for root passes
- (2) 1/4 in. (6 mm) for horizontal fillet welds
- (3) 1/4 in. (6 mm) for root passes of fillet welds

made in the flat position and groove welds made in the flat position with a backing and a root opening of 1/4 in. (6 mm) or more

(4) 3/16 in. (5 mm) for welds made with EXX14 and low-hydrogen electrodes in the vertical and overhead positions

(5) 3/16 in. (5 mm) for root passes of groove welds and for all other welds not included under (1), (2), (3), and (4)

6.2.2 The minimum size of a root pass shall be large enough to avoid weld metal cracking.

6.2.3 The maximum thickness of layers of fillet welds, other than root passes, and all layers of groove welds shall be

(1) 1/4 in. (6 mm) for root passes of groove welds

(2) 1/8 in. (3 mm) for subsequent layers of welds made in the flat position

(3) 3/16 in. (5 mm) for subsequent layers of welds made in the vertical, overhead, and horizontal positions

6.2.4 The maximum size of both single-pass, and root-pass fillet welds shall be

(1) 3/8 in. (9.5 mm) in the flat position

(2) 5/16 in. (8 mm) in horizontal and overhead positions

(3) 1/2 in. (13 mm) in the vertical position

6.2.5 The progression of welding in the vertical position may be upwards or downwards, but only in the direction or directions for which the welder is qualified.

6.2.6 Complete-joint-penetration groove welds that are made without the use of steel backing shall have the root of the first weld gouged or ground to sound metal before the second weld is started on the opposite side.

6.3 Submerged Arc Welding

6.3.1 General Requirements

6.3.1.1 Submerged arc welding may be performed with one or more single electrodes, one or more parallel electrodes, or combinations of single and parallel electrodes. The spacing between multiple arcs shall be such that the slag cover over the weld metal produced by a leading arc does not cool sufficiently to prevent proper fusion of the weld metal deposit from a following electrode. Submerged arc welding with multiple electrodes may be used for any groove or fillet weld pass.

6.3.1.2 The following paragraphs (6.3.1.3 through 6.3.1.7) governing the use of submerged arc welding are suitable for any steel included in Table 1, other than quenched-and-tempered steels. Concerning the quenched-and-tempered steels, it is necessary to comply with the steel producer's recommendations for maximum permissible heat input and preheat combinations. Such considerations must include the additional heat input produced in simultaneous welding on two sides of a common member.

6.3.1.3 The size of the electrode shall not exceed 1/4 in. (6 mm) diameter.

6.3.1.4 Surfaces on which submerged arc welds are to be deposited and adjacent faying surfaces shall be clean and free of moisture and other containments that may have an adverse effect on weld quality.

6.3.1.5 Roots of groove or fillet welds may be backed with copper, flux, glass tape, iron powder, or similar materials to prevent melt-through, or be sealed by means of root passes deposited using a low-hydrogen welding procedure.

6.3.1.6 The depth or the maximum width, or both, of the weld metal deposited in each weld pass shall not exceed the width of the face of that weld pass (see Fig. 11).

6.3.1.7 Tack welds located in the root of joints requiring specific root penetration, or in the form of fillet welds 3/8 in. (9.5 mm) and under in size shall not produce objectionable changes in appearance of the weld surface or result in decreased penetration. Tack welds that cause unsatisfactory weld characteristics shall be reduced in size by any suitable means before welding. Tack welds in the root of a joint with steel backing of less than 5/16 in. (8 mm) thick shall either be reduced in size by any suitable means before welding or a root pass made continuous for the full length of the joint using a low-hydrogen welding procedure. After any tack weld is reduced in size, care must be taken to clean the weld groove before proceeding.

6.3.2 **Electrodes and Fluxes.** The bare electrodes and flux used in combination for submerged arc welding of a steel shall conform to the requirements of the latest edition of AWS A5.17, *Specification for Carbon Steel Electrodes and Fluxes for Submerged Arc Welding*, or of AWS A5.23, *Specification for Low Alloy Steel Electrodes and Fluxes for Submerged Arc Welding*, whichever is applicable.

6.3.3 **Condition of Flux.** Flux used for submerged arc welding shall be dry and free of contamination from dirt, mill scale, or other foreign material. Flux shall be purchased in packages that can be stored under normal conditions for at least six months without affecting the welding characteristics of the flux or the weld properties. Flux from damaged packages shall be discarded or dried at a minimum temperature of 250° F (120° C) for 1 hour before use. Flux shall be placed in the dispensing system immediately upon opening a package. Before using flux that has been exposed to the atmosphere in an open package, the top 1 in. (25 mm) shall be discarded. Flux that has been wet shall not be used. Flux that is fused in welding shall not be reused.

6.3.4 Procedures for Submerged Arc Welding with a Single Electrode

6.3.4.1 Submerged arc welds may be made in either

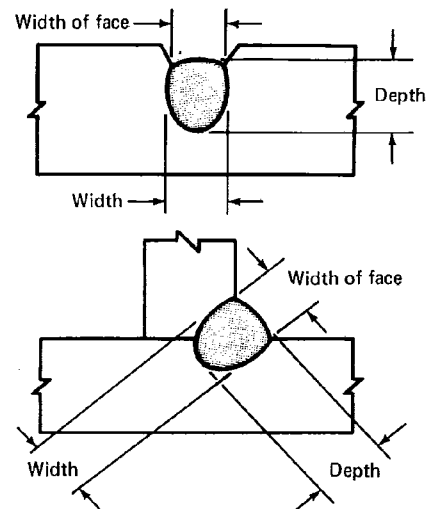

Fig. 11—Unacceptable submerged arc weld pass where the depth and width exceed the face width

the flat or horizontal position. Single-pass fillet welds made in the horizontal position shall not exceed 5/16 in. (8 mm) in size.

6.3.4.2 The thickness of weld layers, except root and surface layers, shall not exceed 1/4 in. (6 mm). When the root opening is 1/2 in. (13 mm) or greater, a multiple-stringer bead (split layer) technique shall be used. The stringer bead (split layer) technique shall also be used in making multiple-pass welds when the width of the layer will exceed 5/8 in. (16 mm).

6.3.4.3 The welding conditions, including current, arc voltage, and speed of travel, shall insure that each weld pass will have complete fusion with the adjacent base and weld metals, and have no overlap or unacceptable undercut. The maximum welding current used to make any weld pass with fusion to both faces of a weld groove shall be 800A, except that the final layer of weld metal may be made using higher welding current. The maximum welding current to be used for fillet welds in the flat position shall be 1,000A.

6.3.5 Procedures for Submerged Arc Welding with Multiple Electrodes

6.3.5.1 Submerged arc welds made with multiple electrodes may be made in either the flat or horizontal position. Single-pass, multiple-arc fillet welds made in the horizontal position shall not exceed 1/2 in. (13 mm) in size.

6.3.5.2 The thickness of weld layers is not limited. In making the root pass of a groove weld, either single or multiple electrodes may be used. Backing strips or root

50/SPECIFICATION FOR WELDING OF INDUSTRIAL & MILL CRANES

faces of the groove shall be of adequate thickness to prevent melt-through. When the width of a groove in which a layer of weld metal is to be deposited exceeds 1/2 in. (13 mm), multiple electrodes shall be displaced laterally, or a stringer bead (split layer) technique shall be used to assure complete fusion. A stringer bead (split layer) technique shall be employed when only two electrodes in tandem are used, and the width of a previously deposited layer exceeds 1 in. (25 mm).

6.3.5.3 The welding conditions, including current, arc voltage, speed of travel, and relative location of electrodes, shall insure that each pass will have complete fusion with the adjacent base and weld metals, and have no depressions or unacceptable undercut. Concavity of initial weld passes shall not be excessive to avoid cracking in roots of joints that are under restraint.

6.3.5.4 The maximum welding current used in making a groove weld shall be

(1) 700A for any single electrode or for parallel electrodes when making a root pass of a multiple-pass weld in a groove having no root opening

(2) 750A for any single electrode or 900A for parallel electrodes when making a root pass in a groove having steel backing or a spacer bar

(3) 1000A for any single electrode or 1200A for parallel electrodes for all other passes except the root pass and the final layer

(4) Any suitable amperage for the final pass or layer

6.3.5.5 The maximum welding current to be used when making a fillet weld shall be 1000A for a single electrode or 1200A for parallel electrodes.

6.3.5.6 Multiple electrodes may be used in the root of groove or fillet welds using a leading gas metal arc electrode with gas shielding followed by multiple submerged arc electrode provided that (1) the gas metal arc welding conforms to the requirements of 6.4 and (2) the spacing between the leading gas metal arc electrode and the first following submerged arc electrode is not more than 15 in. (381 mm).

6.4 Gas Metal Arc and Flux Cored Arc Welding

6.4.1 Consumables

6.4.1.1 The electrodes and shielding medium for gas metal arc welding (GMAW) or flux cored arc welding (FCAW) for producing weld metal with a minimum specified yield strength of 60,000 psi (415 MPa), or less, shall conform to the requirements of the latest edition of AWS A5.18, *Specification for Carbon Steel Filler Metals for Gas Shielded Arc Welding* or AWS A5.20, *Specification for Carbon Steel Electrodes for Flux Cored Arc Welding*, as applicable.

6.4.1.2 Weld metal having a minimum specified

yield strength greater than 60,000 psi (415 MPa) shall conform to the following requirements:

(1) The electrodes and shielding gas for gas metal arc welding for producing weld metal with a minimum specified yield strength greater than 60,000 psi (415 MPa) shall conform with the latest edition of AWS A5.28, *Specification for Low Alloy Steel Filler Metals for Gas Shielded Arc Welding*.

(2) The electrodes and shielding gas for flux cored arc welding for producing weld metal with a minimum specified yield strength greater than 60,000 psi (415 MPa) shall conform to the latest edition of AWS A5.29, *Specification for Low Alloy Steel Electrodes for Flux Cored Arc Welding*.

6.4.1.3 When requested by the design engineer, the manufacturer shall furnish the electrode producer's certification that the electrode will meet the requirements of the classification or grade in the applicable specification.

6.4.2 Shielding Gas. When a gas or gas mixture is used for shielding during gas metal arc or flux cored arc welding, it shall be welding grade having a dew point of -40° F (-40° C) or lower. When requested by the design engineer, the manufacturer shall furnish certification from the gas producer that the gas or gas mixture is suitable for the intended application and meets the dew point requirement.

6.4.3 Prequalified Procedures for Gas Metal Arc¹² and Flux Cored Arc Welding. The requirements for prequalified procedures that are exempt from qualification testing are as follows:

6.4.3.1 Electrodes shall be dry and in suitable condition for use.

6.4.3.2 The maximum diameter of electrodes shall be 5/32 in. (4 mm) for the flat and horizontal position, 3/32 in. (2.3 mm) for the vertical position, and 5/64 in. (2 mm) for the overhead position.

6.4.3.3 The maximum size of a fillet weld made in one pass shall be 1/2 in. (13 mm) for the flat and vertical position, 3/8 in. (9.5 mm) for the horizontal position, and 5/16 in. (8 mm) for the overhead position.

6.4.3.4 The thickness of weld layers, except the root and surface layers, shall not exceed 1/4 in. (6 mm). A multiple-pass, stringer bead (split layer) technique shall be used when the root opening of a groove weld is greater than 1/2 in. (13 mm). The stringer bead (split layer) technique shall also be used in making all multiple-pass welds (fillet or groove) when the width of the preceding layer exceeds 5/8 in. (16 mm).

6.4.3.5 The welding conditions used shall insure that

12. Apply only when welding with the spray, drop, or globular metal transfer. Prequalification does not apply to short-circuiting metal transfer.

each pass will have complete fusion with adjacent base metal and weld metal, and there will be no excessive overlap, porosity, or undercutting.

6.4.3.6 Complete-joint-penetration groove welds made without the use of steel backing shall have the root of the first weld gouged to sound metal before the second weld is started from the opposite side of the joint.

6.4.3.7 Backing may be used to prevent melt-through at the roots of fillet welds and partial penetration groove welds.

6.4.3.8 Welding with external gas shielding shall not be done in a draft or wind having a velocity exceeding 5 miles per hour unless the weld is protected by a shelter. The shelter shall reduce the air velocity in the vicinity of the welding to that necessary to avoid loss of gas shielding.

6.5 Stud Welding

6.5.1 Scope. This section contains provisions for the installation and inspection of steel studs, welded to steel, to fasten other members to girders.

6.5.2 General Requirements

6.5.2.1 Studs shall be of designs suitable for arc welding to steel members with automatically timed stud welding equipment. The type, size or diameter, and length of studs shall be as specified by the drawings, specifications, or special provisions approved by the design engineer.

6.5.2.2 An arc shield (ferrule) of heat-resistant ceramic or other suitable material shall be used with each stud.

6.5.2.3 A suitable deoxidizing and arc-stabilizing flux for welding shall be furnished with each stud of 5/16 in. (8 mm) or larger. Studs less than 5/16 in. (8 mm) in the diameter may be furnished with or without flux.

6.5.3 Quality Control

6.5.3.1 Before starting the welding operations, 2 stud connectors shall be welded to a separate plate of a thickness and material similar to the member and in the same general welding position (flat, vertical, overhead, or sloping) as the member. After being allowed to cool, both welded studs shall be tested by bending them to an angle of 30 degrees from the original axis by striking them with a hammer. If failure occurs in the weld zone of either stud during bending, the welding procedure shall be modified and the test repeated until 2 studs are successfully welded and bend tested before any production studs are welded to the member. The foregoing testing shall also be performed after any change in the welding procedure. If failure occurs in a stud shank, an investigation shall be made to ascertain the cause and correct the welding procedure before more studs are welded.

6.5.3.2 Studs shall be inspected in accordance with

8.18, and repairs shall be made, as necessary, in accordance with 10.6.

6.6 Electroslag and Electrode Gas Welding

6.6.1 General Requirements

6.6.1.1 Electroslag and electrode gas welding of quenched-and-tempered steels is not permitted unless the heat-affected zone and weld are heat-treated subsequent to welding to obtain the required mechanical properties.

6.6.1.2 Prior to use, the manufacturer shall prepare a procedure specification and qualify each procedure for the process to be used in accordance with the requirements of Section 7. The procedure specification shall include the joint details, filler metal type and diameter, welding current and type, voltage, speed of vertical travel (if not an automatic function of arc length or disposition rate), oscillation (traverse speed, distance, and dwell time) type of shielding (including flow rate and dew point of gas or type of flux), type of molding shoe, postweld heat treatment (if required), and other pertinent information.¹³

6.6.2 Impact Strength Requirements. Impact tests shall be included in the welding procedure qualification.

6.6.2.1 Five Charpy V-notch impact test specimens shall be machined from the same weld test assembly made to determine weld joint properties.

6.6.2.2 The impact specimens shall be machined and tested in accordance with ASTM E23, *Standard Methods for Notched Bar Impact Testing of Metallic Materials*, or AWS B4.0, *Standard Methods for Mechanical Testing of Welds*, for Type A Charpy impact specimens.

6.6.2.3 The longitudinal centerline of the specimens shall be transverse to the weld axis, and shall be located as near as practicable to a point midway between the surface and center of thickness. The base of the notch shall be perpendicular to the surface. The standard 0.394 in. x 0.394 in. (10 mm x 10 mm) specimen shall be used where the thickness is 1/2 in. (13 mm) or greater. For thinner material, the largest practical size listed in Table 10 shall be used.

6.6.2.4 When computing the average value of the impact properties, the lowest value and highest value obtained with the 5 specimens tested shall be disregarded.

6.6.2.5 The notched bar impact properties of the weld metal of the remaining 3 specimens shall be no less than the values in Table 10 when tested at 0° F (-18° C).

6.6.3 All-Weld-Metal Tension Tests. Prior to use, the

13. The resistance of an electroslag or electrode gas weld to centerline hot cracking is related to the angle at which the dendritic grains meet as solidification of the weld metal proceeds. This angle is determined by the shape of the molten weld pool. In general, if the angle is acute (less than 90 degrees), the cracking resistance will be high. Refer to the *Welding Handbook*, Vol. 2, 7th Ed., pages 243-45 for additional information.

52/SPECIFICATION FOR WELDING OF INDUSTRIAL & MILL CRANES

manufacturer shall demonstrate by appropriate tests that each combination of shielding media and filler metal will produce welds having the mechanical properties specified in the latest edition of AWS A5.24 or A5.26, or as listed in Table 11.

6.6.4 Electrodes and consumable guide tubes shall be dry, clean, and in suitable condition for use.

6.6.5 A gas or gas mixture used as shielding for electrogas welding shall be of a welding grade and have a dew point of -40°F (-40°C), or lower.

6.6.6 The flux used for electroslag welding shall be dry and free of contamination from dirt, mill scale, or other foreign material. Flux from packages damaged in transit or handling shall be discarded or dried at a minimum temperature of 250°F (120°C) for 1 hour before use.

6.6.7 Procedures for Electroslag and Electrogas Welding

6.6.7.1 Electrogas welding shall not be done in a draft or wind unless the weld area is protected by a shelter. This shelter shall be designed to reduce the wind velocity in the vicinity of the weld to conditions where the gas shielding is not disrupted.

6.6.7.2 The type and diameter of the electrodes used shall meet the requirements of the procedure specification.

6.6.7.3 Welds shall be started in such a manner as to permit sufficient heat buildup for complete fusion of the weld metal to the groove faces of the joint. Welds stopped at any point in the length of the joint shall be examined in accordance with Section 8, and repaired if necessary.

Table 10
Impact strength requirements for electrogas
and electroslag welds

Specimen size		Min avg impact strength		Min impact strength	
in.	mm	ft lb	J	ft lb	J
0.394 x 0.394	10 x 10	15.0	20.3	10.0	13.6
0.394 x 0.295	10 x 7.5	12.5	17.0	8.5	11.5
0.394 x 0.197	10 x 5.0	10.0	13.6	7.0	9.5
0.394 x 0.098	10 x 2.5	5.0	6.8	3.5	4.7

Table 11
All-weld-metal tension test requirements for electrogas and electroslag welds

Base metal	Min tensile strength,		Min yield point,		Min elongation, %	
	ksi	MPa	ksi	MPa	in	2 in. (51 mm)
ASTM A36	60	415	36	250	24	
ASTM A242 or A441, thickness: 3/4 in. (20 mm) or less	70	485	50	345	22	
Over 3/4 to 1-1/2 in. (20-38 mm)	67	460	46	315	22	
Over 1-1/2 to 4 in. (38-102 mm)	63	435	42	290	24	
Over 4 to 8 in. (102-203 mm)	60	415	40	275	24	
ASTM A572:						
Grade 42	60	415	42	290	24	
Grade 45	60	415	45	310	22	
Grade 50	65	450	50	345	21	
Grade 55	70	485	55	380	20	
Grade 60	75	515	60	415	18	
Grade 65	80	550	65	450	17	
ASTM A588, thickness:						
4 in. (102 mm) or less	70	485	50	345	21	
Over 4 to 5 in. (102-127 mm)	67	460	46	315	21	
Over 5 to 8 in. (127-202 mm)	63	435	42	290	21	

6.6.7.4 Preheating of base metals is not normally required. However, welding shall not be performed when the base metal at the point of welding is below 32° F (0° C).

6.6.7.5 Welds not meeting the quality requirements of Section 8 shall be repaired utilizing a qualified welding process.

7. Qualification

Part A General Requirements

7.1 Approved Procedures

7.1.1 Joint welding procedures that conform in all respects to the provisions of Section 2, Base Metals; Section 4, Weld Joint Design; Section 5, Workmanship; and Section 6, Processes and Filler Metals, shall be deemed prequalified and are exempt from tests or qualification.

7.1.2 All prequalified joint welding procedures (WPS) prepared by the manufacturer, fabricators, or contractor shall be in writing and be available to those authorized to examine them. A suggested form showing the information required in a procedure specification is shown in Appendix A.

7.1.3 A combination of qualified or prequalified joint welding procedures may be used without requalification, provided the limitations of essential variables applicable to each process are observed. This combination of joint welding procedures shall be written as a single weld procedure.

7.1.4 Procedures previously qualified under earlier editions of this specification, AWS D1.1, *Structural Welding Code-Steel*, or ASME Codes for equivalent welding shall be acceptable under this specification, subject to the limitation of variables in Section 7. Requalification or new qualifications shall be made in accordance with the requirements of this edition.

7.1.5 Testing of new processes, filler metals,¹⁴ and fluxes shall be qualified by the following:

(1) For groove welds, the reduced-section tension test and the guided-bend test shall be used. As an alternative, a simulated proof test¹⁵ of the applicable joint may be used subject to the design engineer's approval.

14. The term new process or filler metal refers to a newly applied process or a fillet metal that has no previous qualification record by the manufacturer for the intended application.

15. Simulated proof tests are now included to utilize certain workmanship specimens. The Committee considered certain cases where joints of odd or unusual configuration would not lend themselves to the reduced-section tension or guided-bend tests, and agreed that such joints may be tested under actual load conditions. This is also intended for joints loaded in fatigue.

(2) For fillet weld applications only, the transverse or longitudinal fillet weld tests (Figs. 12A and B) shall be used. As an alternative, a simulated proof test of the applicable joint may be used, subject to the design engineer's approval.

7.2 Other Procedures. Except for those procedures exempted in 7.1.1, joint welding procedures that are employed in executing contract work under this specification shall be qualified prior to use by tests as prescribed in Part B of this section to the satisfaction of both the purchaser's appointed representative and the manufacturer's designated representative responsible for welding. The purchaser's appointed representative should accept evidence of previous qualification of any joint welding procedures to be employed.

7.3 Welders, Welding Operators, and Tack Welders

7.3.1 All welders, welding operators, and tack welders to be employed under this specification shall have been qualified by tests as prescribed in Parts C, D, and E of this section. Purchaser's representatives, at their discretion, should accept evidence of previous qualification of the welders, welding operators, and tack welders to be employed. A suggested form showing the information required is shown in Appendix A.

7.3.2 Radiographic or ultrasonic examination of a welder's or welding operator's qualification test plate, or test pipe, may be made in lieu of the guided-bend test prescribed in Parts C and D of this section.

7.4 Qualification Responsibility. Each manufacturer or contractor shall conduct the tests required by this specification to qualify the welding procedures and the welders, welding operators, and tack welders who will use these procedures.

Part B Procedure Qualification

7.5 Limitation of Variables

7.5.1 The following rules apply when it is necessary to establish a welding procedure by qualification as required by 7.2 or the contract specifications, and the procedure shall be recorded by the manufacturer as a welding procedure specification.

7.5.1.1 Qualification of a welding procedure using a steel that is listed in Table 1, but not in 7.5.1.2, and has a minimum specified yield point of less than 50,000 psi (345 MPa) shall qualify the procedure for welding any other steel or combination of steels listed in the Table that

54/SPECIFICATION FOR WELDING OF INDUSTRIAL & MILL CRANES

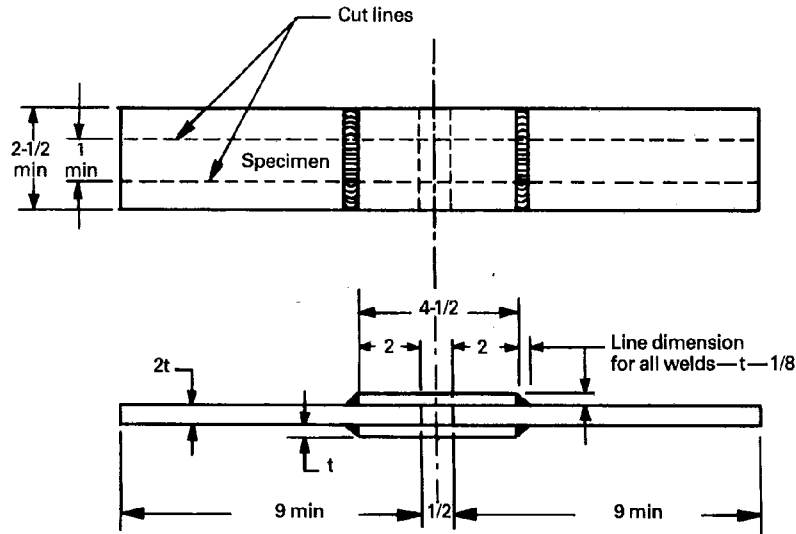

Note: Dimensions are in inches

Fig. 12A—Transverse fillet weld shearing specimen

have a minimum specified yield point equal to or less than that of the base metal used in the test.

7.5.1.2 Qualification of a welding procedure established with A551; A537, C1.1; A572, Gr 42 through 50; API 5LX, Gr 42; or ABS, Gr AH, DH, or EH shall be considered as procedure qualification for welding any other steel or combinations of steels in this group, or other steels included in Table 1 that have a lower minimum specified yield point.

7.5.1.3 Qualification of a welding procedure established with a base metal included in Section 2 and having a minimum specified yield strength greater than 50,000 psi (345 MPa) shall qualify the procedure for welding only base metal of the same material specification and grade or type that have the same minimum specified yield strength as the base metal tested, the permitted reduction in yield strength for increased material thickness being excepted. For example, a procedure qualified with a 1 in. (25 mm) thick, 100,000 psi (690 MPa) yield strength base metal also qualified for a 3 in. (76 mm) thick, 90,000 psi (620 MPa) yield strength base metal of the same material specification.

7.5.1.4 Qualification of a welding procedure established with a combination of base metals included in Table 1 of different minimum specified yield strengths, one of which is greater than 50,000 psi (345 MPa), shall qualify the procedure for welding that high yield strength base metal to any other of those base metals that have a minimum specified yield strength equal to or less than that of the lower strength base metal used in the test.

7.5.1.5 The variables listed in 7.5.2 are essential variables of a joint welding procedure. In preparing the procedure specification, the manufacturer or contractor shall report the specific values for the essential variables in 7.5.2. The suggested form for showing the information required in the procedure specification is shown in Appendix A.

7.5.2 Limitations of Variables. The changes set forth in 7.5.2.1 through 7.5.2.5 shall be considered essential changes in a welding procedure. Any changes exceeding the limitations thereof shall require establishment of a new procedure incorporating those changes by qualification. When a combination of welding processes is used, the variables applicable to each process shall apply.

7.5.2.1 Shielded Metal Arc Welding

(1) A change increasing filler metal strength levels (for example, a change from E70XX to E80XX, but not vice versa).

(2) A change from a low hydrogen-type electrode to a non-low hydrogen-type electrode, but not vice versa.

(3) An increase in the diameter of the electrode used over that called for in the procedure specification.

(4) A change of more than 15 percent above or below the specified mean arc voltage or amperage for each size electrode used.¹⁶

(5) For a specified welding groove, a change of more than ± 25 percent in the specified number of passes.

16. When welding quenched-and-tempered steel, any change within the limitation of variables shall not increase the heat input beyond the steel producer's recommendations.

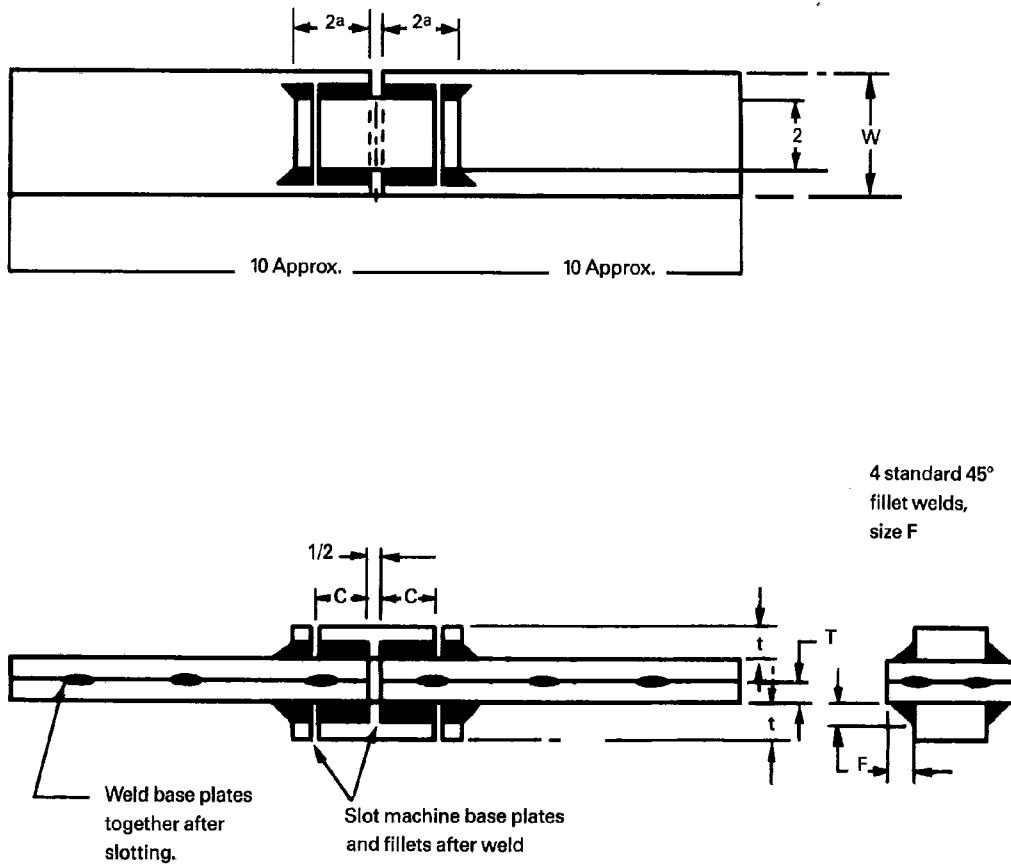

Note: Dimensions are in inches

Size of weld, F		Thickness, t , min		Thickness, T, min		Width, W		Fillet length, C	
in.	mm	in.	mm	in.	mm	in.	mm	in.	mm
1/8	3.2	3/8	9.5	1/4	6.4	3	76.2	1-1/2	38.1
1/4	6.4	1/2	12.7	3/8	9.5	3	76.2	1-1/2	38.1
3/8	9.5	3/4	19.1	1/2	12.7	3	76.2	1-1/2	38.1
1/2	12.7	1	25.4	5/8	15.9	3-1/2 ^b	88.9	1	25.4

(a) Increase to 3 in. (76.2 mm) for submerged arc welds to allow for craters.

(b) For 7 in. (177.8 mm) on each end of the base plates, the 3-1/2 in. (88.9 mm) width may have to be reduced to 3 in. (76.2 mm) to accommodate the jaws of the test machine.

Fig. 12B—Longitudinal fillet weld shear specimen

56/SPECIFICATION FOR WELDING OF INDUSTRIAL & MILL CRANES

If the area of the groove is increased, it is also permissible to increase the number of passes in proportion to the change in area.

(6) A change in position in which welding is done, as defined in 7.8.

(7) A change in the type of groove (a change from a V- to a U-groove, for example).

(8) A change in the shape of any one type of groove exceeding the tolerances given in Section 4 involving

- (a) A decrease in the included angle of the groove
- (b) A decrease in the root opening of the groove
- (c) An increase in the root face of the groove
- (d) The omission, but not inclusion, of backing material

(9) A decrease of more than 25° F (14° C) in the minimum specified preheat or interpass temperature.

(10) In vertical welding, a change in the progression specified for any pass from upward to downward, or vice versa.

(11) The omission but not the inclusion of back gouging.

7.5.2.2 Submerged Arc Welding

(1) A change in the electrode-flux combination not covered by AWS A5.17 or A5.23.

(2) A change increasing the filler metal strength level (for example, from Grade F80 to Grade F90, but not vice versa).

(3) A change in electrode diameter when using an alloy flux.¹⁷

(4) A change in the number of electrodes used.

(5) A change in the type of current (ac or dc) or polarity when welding quenched-and-tempered steel, or when using an alloy flux.

(6) A change of more than 10 percent above or below the specified mean amperage for each electrode diameter used.¹⁶

(7) A change of more than 7 percent above or below the specified mean arc voltage for each diameter electrode used.¹⁶

(8) A change of more than 15 percent above or below the specified mean travel speed.¹⁶

(9) A change of more than 10 percent, or 1/8 in. (3 mm), whichever is greater, in the longitudinal spacing of multiple arcs.

(10) A change of more than 10 percent, or 1/16 in. (1.6 mm), whichever is greater, in the lateral spacing of multiple arcs.

(11) A change of more than ± 10 degrees in the angular position of any parallel electrode.

(12) A change in the angle of electrodes in machine

or automatic welding of more than

(a) ± 3 degrees in the direction of travel

(b) ± 5 degrees normal to the direction of travel

(13) For a specified groove, a change of more than ± 25 percent in the specified number of passes. If the area of the groove is changed, it is permissible to change the number of passes in proportion to change in the area.

(14) A change in position in which welding is done as defined in 7.8.

(15) A change in the type of groove (a change from a V- to a U-groove, for example).

(16) A change exceeding the tolerance of Section 4 in the shape of any one type of groove involving

(a) A decrease in the included angle of the groove

(b) A decrease in the root opening of a groove

(c) An increase in the root face of the groove

(d) The omission, but not inclusion, of backing material

(17) A decrease of more than 25° F (14° C) in the minimum specified preheat or interpass temperature.

(18) An increase in the diameter of the electrode used over that called for in the procedure specification.

(19) The addition or deletion of supplemental powdered, granular, or cut wire filler metal.

(20) An increase in the amount of supplemental powdered, granular, cut wire filler metal.

(21) If the alloy content of the weld metal is largely dependent on the composition of supplemental powdered filler metal, any change in the joint welding procedure that would result in the content of important alloying elements in the weld metal not meeting the chemical requirements given in the welding procedure specification.

(22) The omission, but not the inclusion, of back gouging.

7.5.2.3 Gas Metal Arc Welding

(1) A change in the electrode and method of shielding not covered by AWS A5.18 or A5.28.

(2) A change in filler metal to one of higher strength level, but not vice versa (for example, E70s to Grade E80s).

(3) A change in electrode diameter.

(4) A change in the number of electrodes used.

(5) A change from a single shielding gas to any other single gas or to a mixture of gases, or a change in specified composition of a gas mixture not covered by AWS A5.18 or A5.28.

(6) A change of more than 10 percent above or below the specified mean amperage for each diameter electrode used.¹⁶

(7) A change of more than 7 percent above or below the specified mean arc voltage for each diameter electrode used.¹⁶

(8) A change of more than 10 percent above or below the specified mean travel speed.¹⁶

17. An alloy flux is defined as a flux upon which the alloy content of the weld metal is largely dependent.

(9) An increase of 25 percent or more or a decrease of 10 percent or more in the flow rate of the shielding gas.

(10) For a specified groove, a change of more than ± 25 percent in the specified number of passes. If the area of the groove is changed, it is permissible to change the number of passes in proportion to the change in area.

(11) A change in the position in which welding is done is defined in 7.8.

(12) A change in the type of groove (for example, a change from a V- to a U-groove).

(13) A change exceeding the tolerances in Section 4 in the shape of any type of welding groove involving:

(a) A decrease in the included angle

(b) A decrease in the root opening

(c) An increase in the root face

(d) The omission, but not inclusion, of backing material

(14) A decrease of more than 25° F (14° C) in the minimum specified preheat or interpass temperature.

(15) In vertical welding, a change in the progression specified for any pass from upward to downward, or vice versa.

(16) A change in type of welding current (ac or dc), polarity, or mode of metal transfer across the arc.

(17) The omission, but not the inclusion, of back gouging.

7.5.2.4 Flux Cored Arc Welding

(1) A change in electrode and method of shielding not covered by AWS A5.20.

(2) A change increasing the filler metal strength level (for example, from Grade E70T to E80T, but not vice versa).

(3) An increase in the diameter of electrode used over that called for in the procedure specification.

(4) A change in the number of electrodes used.

(5) A change from a single shielding gas to any other single gas or to a mixture of gases, or a change in the specified composition of a gas mixture not covered by AWS A5.20.

(6) A change of more than 10 percent above or below the specified mean amperage for each size of electrode used.¹⁶

(7) A change of more than 7 percent above or below the specified mean arc voltage for each size of electrode used.¹⁶

(8) A change of more than 10 percent above or below the specified mean travel speed.¹⁶

(9) An increase of 25 percent or more, or a decrease of 10 percent or more in the rate of flow of shielding gas.

(10) For a specified groove, a change of more than ± 25 percent in the specified number of passes. If the

area of the groove is changed, it is permissible to change the number of passes in proportion to the change in area.

(11) A change in the position in which welding is done, as defined in 7.8.

(12) A change in the type of groove (for example, a change from a V- to a U-groove).

(13) A change exceeding the tolerance in Section 4 in the shape of any type of groove involving:

(a) A decrease in the included angle

(b) A decrease in the root opening

(c) An increase in the root face

(d) The omission, but not inclusion, of backing material

(14) A decrease of more than 25° F (14° C) in the minimum specified preheat or interpass temperature.

(15) In vertical welding, a change in the progression specified for any pass from upward to downward, or vice versa.

(16) A change in type of welding current, (ac or dc) polarity, or mode of metal transfer across the arc.

(17) The omission, but not the inclusion, or back gouging.

7.5.2.5 Electroslag and Electrode Gas Welding

(1) A change in filler metal or consumable guide tube metal composition.

(2) A change in the metal core cross-sectional area of the consumable guide tube exceeding 30 percent.

(3) A change in flux system (cored, magnetic electrode, external flux, etc.).

(4) A change in flux composition, including consumable guide tube covering.

(5) A change in shielding gas composition by a change in flow of any one constituent of a mixture by more than 5 percent of the total gas flow.

(6) A change in welding current exceeding 20 percent.

(7) A change in groove design, other than a square-groove, that increases the groove cross-sectional area.

(8) A change in joint thickness (T) outside the limits of 0.5T to 1.1T, where T is the thickness used for the procedure qualification.

(9) A change in number of electrodes.

(10) A change from single to multiple pass, or vice versa.

(11) A change to a combination with any other welding process or method.

(12) A change in postweld heat treatment.

(13) A change in design of molding shoes, either fixed or movable, from nonfusing solid to water-cooled, or vice versa.

(14) A change exceeding 1/32 in. (0.8 mm) in filler metal diameter.

58/SPECIFICATION FOR WELDING OF INDUSTRIAL & MILL CRANES

(15) A change exceeding 10 in./min (4 mm/s) in filler metal oscillation traverse speed.

(16) A change in filler metal oscillation traverse dwell time exceeding 2 seconds, except as necessary to compensate for variation in the joint opening.

(17) A change in filler metal oscillation traverse length that effects, by more than 1/8 in. (3 mm), the proximity of filler metal to the molding shoes.

(18) A change in flux burden exceeding 30 percent.

(19) A change in shielding gas flow rate exceeding 25 percent.

(20) A change in design of molding shoes, either fixed or movable, as follows:

(a) Metallic to nonmetallic, or vice versa

(b) Nonfusing to fusing, or vice versa

(c) A reduction in any cross-sectional dimension or area of solid nonfusing shoe exceeding 25 percent

(21) A change in welding position from the qualified verticality by more than 10 degrees.

(22) A change of welding current from ac to dc, or vice versa, or a change in electrode polarity for direct current.

(23) A change in welding power volt-ampere characteristics from constant voltage to constant current, or vice versa.

(24) A change in welding voltage exceeding 10 percent.

(25) A change exceeding 1/4 in. (4 mm) in the root opening of a square-groove weld.

(26) A change in groove design that reduces the cross-sectional area.

(27) A change in speed of vertical travel, if not an automatic function of arc length or deposition rate, exceeding 20 percent except as necessary to compensate for variation in joint opening.

7.6 Types of Tests and Purposes. The tests that are used to determine the mechanical properties and soundness of welded joints made to qualify a welding procedure are as follows:

7.6.1 For Groove Welds

- (1) Reduced-section tension test for tensile strength
- (2) Root-, face-, and side-band tests for soundness
- (3) Radiographic test for soundness
- (4) Ultrasonic test for soundness
- (5) All-weld-metal tension test for mechanical properties

(6) Impact test for toughness

(7) Macroetch test for solidification patterns

7.6.2 For Fillet Welds. Macroetch test for soundness.

7.7 Base Metal. The base metal and the preparation for welding shall be that specified in the procedure specification being qualified. For all types of welded joints, the

length of the welded joint and dimensions of the base metal shall provide sufficient material for the required test specimens.

7.8 Position of Test Welds

7.8.1 All welds that will be encountered in actual construction shall be classified as flat, horizontal, vertical, or overhead.

7.8.2 Plate Groove Weld Tests. When making tests to qualify welding procedures for groove welds in plate, test plates shall be welded in each of the positions to be qualified as follows:

(1) Position 1G (flat) — The test plates shall be placed in an approximately horizontal plane and the weld metal deposited on the upper side. See Fig. 13(A).

(2) Position 2G (horizontal) — The test plates shall be placed in an approximately vertical plane with the groove approximately horizontal. See Fig. 13(B).

(3) Position 3G (vertical) — The test plates shall be placed in an approximately vertical plane with the groove approximately vertical. See Fig. 13(C).

(4) Position 4G (overhead) — The test plates shall be placed in an approximately horizontal plane, and the weld metal deposited on the under side. See Fig. 13(D).

7.8.3 Pipe Groove Weld Tests. When making tests to qualify welding procedures for groove welds in pipe, test pipes shall be welded in each of the positions to be qualified as follows:

(1) Position 1G (pipe horizontal, rolled) — The test pipe shall be placed with its axis horizontal and the groove approximately vertical. The pipe shall be rotated during welding so the weld metal is deposited on the upper side. See Fig. 14(A).

(2) Position 2G (pipe vertical) — The test pipe shall be placed with its axis vertical to the welding groove approximately horizontal. The pipe shall not be rotated during welding. See Fig. 14(B).

(3) Position 5G (pipe horizontal, fixed) — The test pipe shall be placed with its axis horizontal and the groove approximately vertical. The pipe is not rotated during welding. See Fig. 14(C).

(4) Position 6G (pipe inclined, fixed) — The test pipe shall be inclined at 45 degrees with the horizontal. The pipe is not rotated during welding. See Fig. 14(D).

7.8.4 Fillet Welds. When making tests to qualify welding procedures for fillet welds, test plates shall be welded in each of the positions to be qualified as follows:

(1) Position 1F (flat) — The test plates shall be so placed that each fillet weld is deposited with its axis and face approximately horizontal, and its throat approximately vertical. See Fig. 15(A).

(2) Position 2F (horizontal) — The test plates shall be so placed that each fillet weld is deposited on the upper

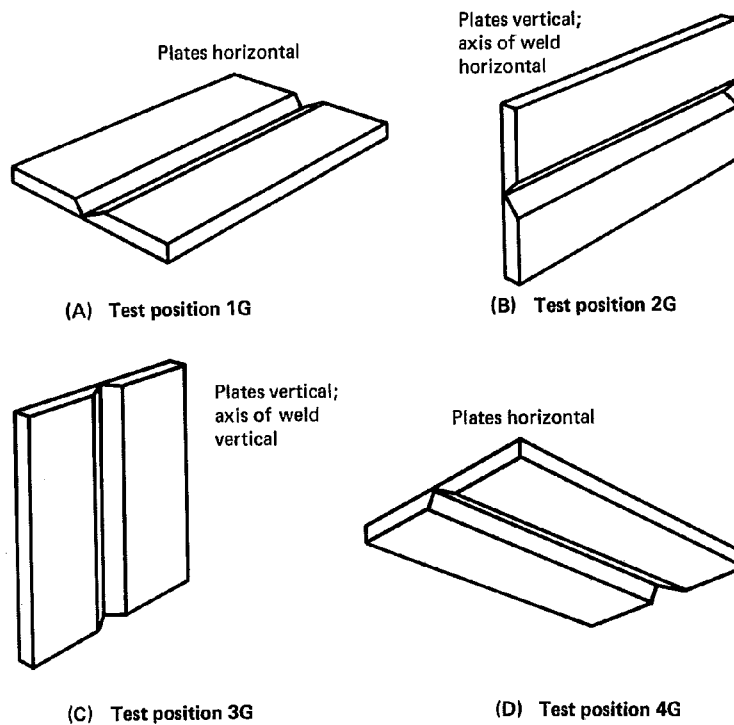

Fig. 13—Positions of test plates for groove welds

side of a horizontal surface and against a vertical surface. See Fig. 15(B).

(3) Position 3F (vertical) — The test plates shall be placed in an approximately vertical plane, and each fillet weld deposited on vertical surfaces with the axis of the weld vertical. See Fig. 15(C).

(4) Position 4F (overhead) — The test plates shall be so placed that each fillet weld is deposited on the underside of a horizontal surface and against a vertical surface. See Fig. 15(D).

7.9 Joint Welding Procedure

7.9.1 The procedure for welding a joint shall comply in all respects with the procedure specification.

7.9.2 Cleaning during the welding of test weld shall be done in the welding position being qualified.

7.10 Test Specimens

7.10.1 Complete-Joint-Penetration Groove Welds

7.10.1.1 The type and number that must be tested to qualify a welding procedure are shown in Table 12, together with the range of thickness that is qualified for use in construction. The range is based on the thickness of the test plate, pipe, or tubing used in making the qualification test.

7.10.1.2 Test specimens to qualify groove welds in T-joints or corner joints shall be butt joints having the same groove configurations as the T-joints or corner joints to be used in construction.

7.10.1.3 Nondestructive Testing. Procedure qualification test plates (Fig. 16A through E) shall be radiographically or ultrasonically tested for soundness before preparing the required mechanical test specimens. Radiographic or ultrasonic testing shall apply only to that portion of the weld between the discard strips, except that a minimum of 6 in. (152mm) of effective weld length shall be examined. The full circumference of a completed weld in pipe or tubing shall be tested. The welding procedure is unacceptable if the test results do not conform to the requirements of 7.12.

7.10.1.4 Mechanical Testing. Test specimens shall be prepared by cutting the welded test plate, pipe, or tubing as shown in Figs. 16A through E, whichever is applicable. The specimens shall be prepared for testing in accordance with Figs. 17A through D, as applicable.

7.10.2 Partial-Joint-Penetration Groove Welds

7.10.2.1 A sample weld shall be made using the type of groove design and joint welding procedure to be used in construction, except that the depth groove need not exceed 1 in. (25 mm). If the partial-joint-penetration

60/SPECIFICATION FOR WELDING OF INDUSTRIAL & MILL CRANES

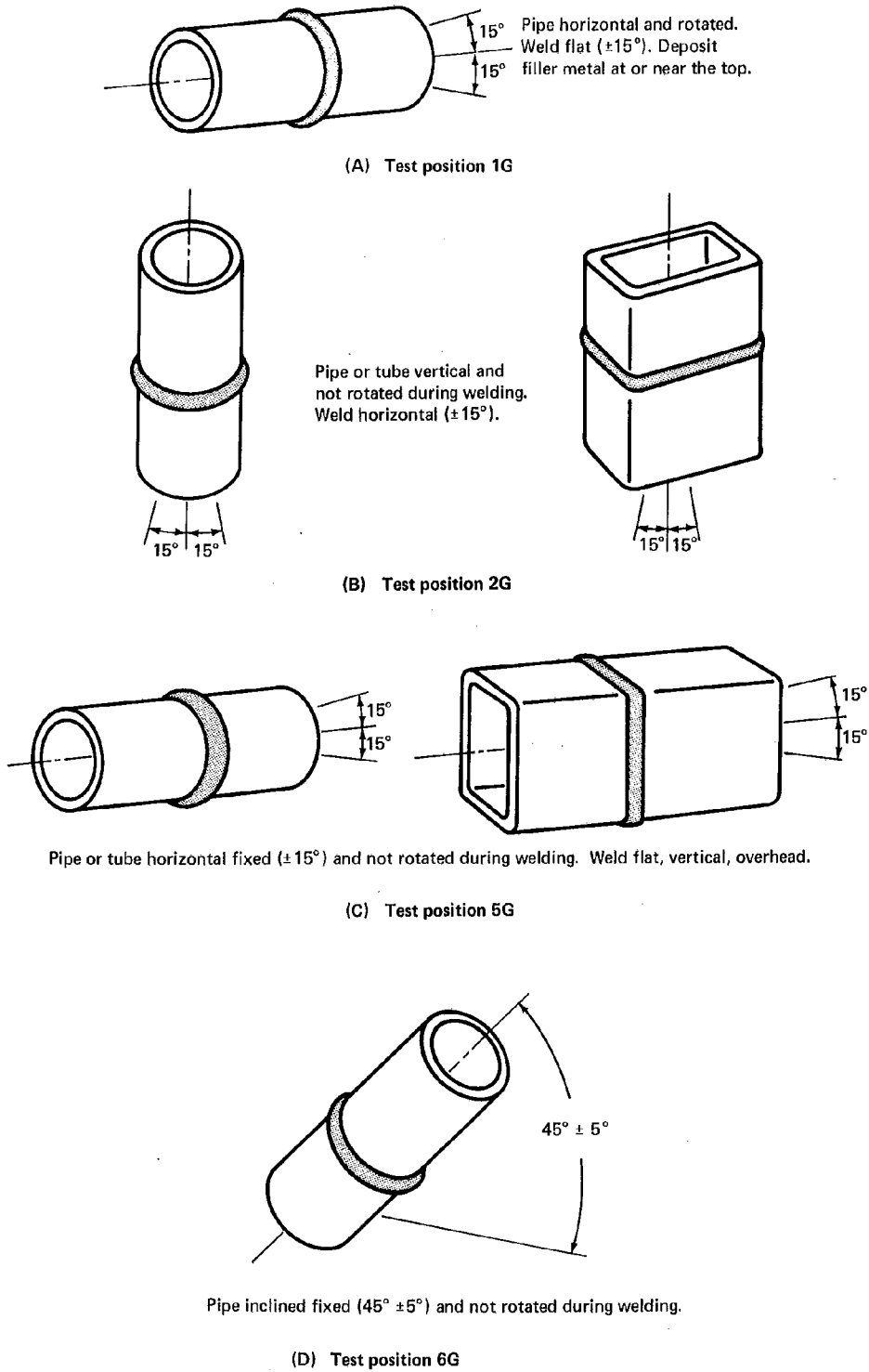

Fig. 14—Positions of test pipe or tubing for groove welds

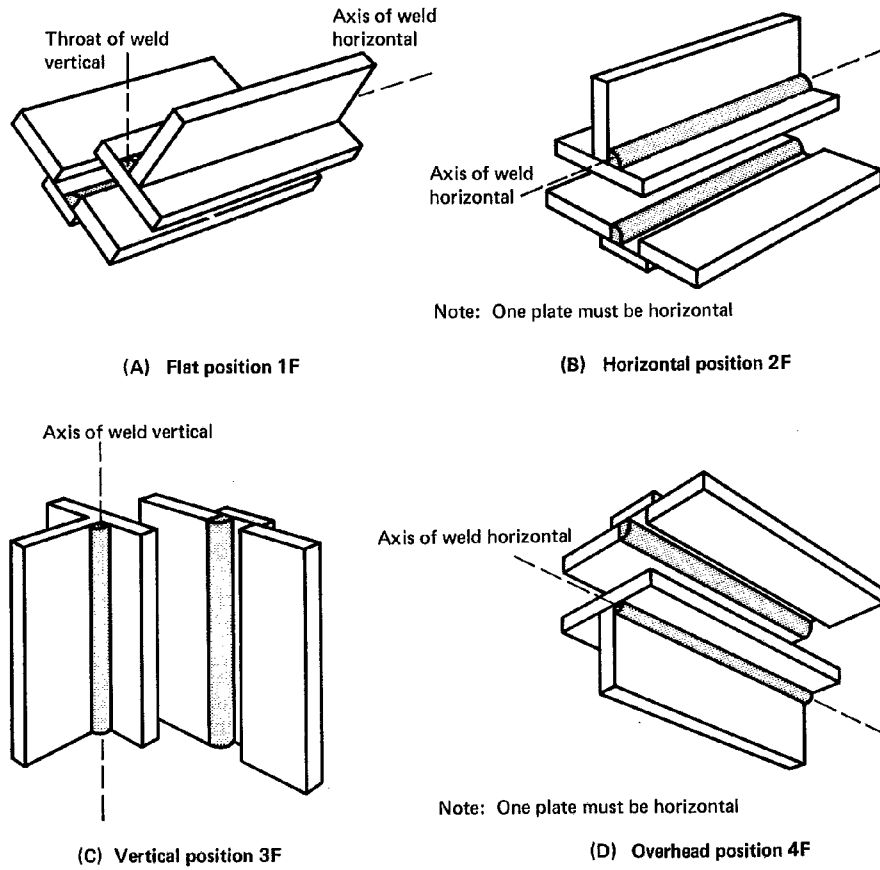

Fig. 15—Positions of test plates for fillet welds

62/SPECIFICATION FOR WELDING OF INDUSTRIAL & MILL CRANES

Table 12
Number and type of test specimens and range of thickness qualified —
procedure qualification; complete-joint-penetration groove welds

1. Tests on plate

Plate thickness (T) tested, in.	Number of sample welds per position	NDT ^(a)	Test specimens required				Plate thickness qualified, T in. maximum ^(b)
			Reduced-section tension (see Fig. 17A)	Root-bend (see Fig. 17A)	Face-bend (see Fig. 17C)	Side-bend (see Fig. 17D)	
1/8 < T < 3/8	1	Yes	2	2	2	—	1/8 to 2T
3/8	1	Yes	2	2	2	—	3/4
3/8 < T < 1	1	Yes	2	—	—	4	2T
1 and over	1	Yes	2	—	—	4	Unlimited

Note: All welded test plates shall be visually inspected (see 7.12.7).

(a) A minimum of 6 in. of effective weld length shall be tested by radiographic or ultrasonic testing prior to mechanical testing.

(b) For square groove welds, qualification shall be limited to thickness tested.

2. Tests on pipe or tubing

Pipe size of sample weld	Number of sample welds per position	NDT ^(a)	Test specimens required				Pipe or tube size qualified		
			Reduced-section tension (see Fig. 17A)	Root-bend (see Fig. 17C)	Face-bend (see Fig. 17C)	Side-bend (see Fig. 17D)	Wall thickness, in.		
Diam wall thickness, T							Diameter, in.	min	max
2 in. Sch. 80 or 3 in. Sch. 40	2	Yes	2	2	2	—	3/4 through 4	0.063	0.674
6 in. Sch. 80 or 8 in. Sch. 120	1	Yes	2	—	—	4	4 and over	0.187	Any
Job size pipe or tubing									
Diam. Wall thickness, T									
1/8 < T < 3/8 in.	1	Yes	2	2	2	—	Test diam and over	1/8	2T
<24 in. 3/8 < T < 3/4 in.	1	Yes	2	—	—	4	Test diam and over	T/2	2T
T > 3/4 in.	1	Yes	2	—	—	4	Test diam and over	0.375	Any
1/8 < T < 3/8 in.	1	Yes	2	2	2	—	Test diam and over	1/8	2T
>24 in. 3/8 < T < 3/4 in.	1	Yes	2	—	—	4	24 and over	T/2	2T
T > 3/4 in.	1	Yes	2	—	—	4	24 and over	0.375	Any

Note: All welded test pipes or tubing shall be visually inspected (see 7.12.6).

(a) For pipe or tubing, the full circumference of the completed weld shall be tested by RT or UT prior to mechanical testing.

(Continued)

Table 12 (continued)

3. Tests on electroslag and electrogas welding

Plate thickness tested	Number of sample welds	NOT ^(a)	Test specimens required				impact tests ^(b) (see 6.6.2)	Plate thickness qualified
			Reduced-section tension (see Fig. 17A)	All-weld-metal Tension (see Fig. 17B)	Side-bend (see Fig. 17D)			
T ^(c)	1	Yes	2	1	4	5	0.5T-1.1T	

Note: All welded test plates shall be visually inspected (see 7.12.7).

(a) 6 in. minimum length of weld shall be tested by radiographic or ultrasonic methods prior to mechanical testing. (see 7.10.1.3.)

(b) If required.

(c) T is the test plate thickness

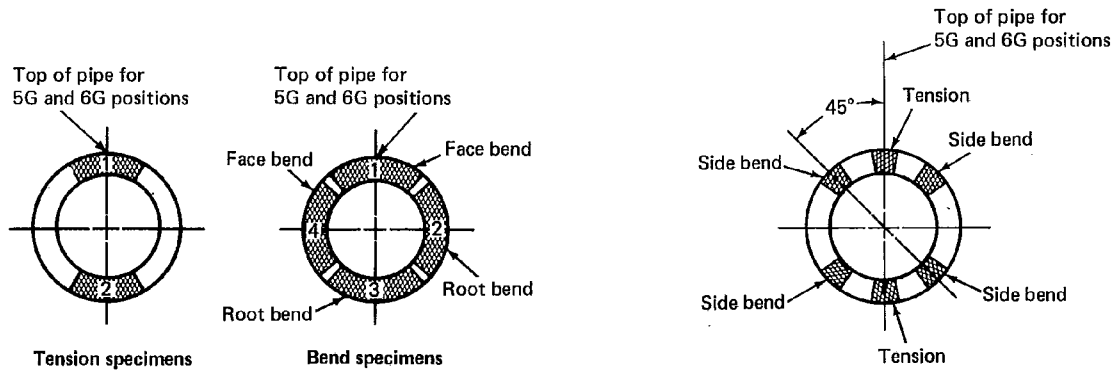

Fig. 16A—Location of test specimens on welded test pipe 2 in. or 3 in. in diameter

Fig. 16B—Location of test specimens on welded test pipe 6 in. or 8 in. in diameter

64/SPECIFICATION FOR WELDING OF INDUSTRIAL & MILL CRANES

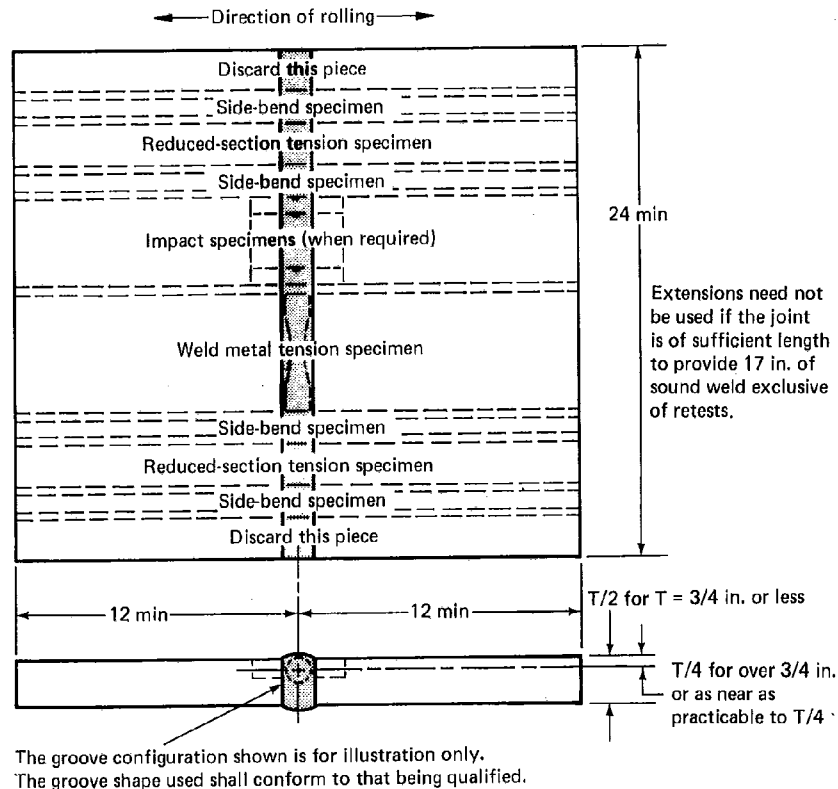

Fig. 16C—Location of test specimens on welded test plate—electroslag and electrogas welding—procedure qualification

groove weld is to be used for corner or T-joints, the butt joint shall have a temporary restrictive plate in the plane of the square face to simulate a T-joint configuration. The sample weld shall first be visually inspected to 7.12.7 and, if acceptable, further tested as follows:

7.10.2.2 For joint welding procedures which conform in all respects to Sections 5 and 6, three macroetch cross section specimens shall be prepared to demonstrate that the designated effective throat (obtained from the requirements of the procedure specification) is met.

7.10.2.3 When a joint welding procedure has been qualified for a complete-joint-penetration groove weld and is applied to the welding conditions of a partial-joint-penetration groove weld, three macroetch cross section test specimens are required.

7.10.2.4 If a joint welding procedure is not covered by either 7.10.2.2 or 7.10.2.3, or if the welding variables do not meet a prequalified status or have not been

used and tested for a complete-joint-penetration groove weld, then a test sample joint must be prepared. The first test on the joint is to make a macroetch test to determine the effective throat of the weld. Next, material is machined from the bottom side of the joint until its thickness is equal to the effective throat of the weld. Tension and bend test specimens shall then be prepared from the test joint, and tests performed as required for complete-joint-penetration groove welds (see 7.10.1).

7.10.3 Fillet Welds. A T-shaped specimen with a double fillet weld, as shown in Fig. 18, shall be made for each welding procedure and welding position to be used in construction. One of the test welds shall be the maximum size single-pass fillet weld, and the other test weld shall be the minimum size multiple-pass fillet weld to be used in construction. The weldments shall be cut perpendicular to the direction of welding at three loca-

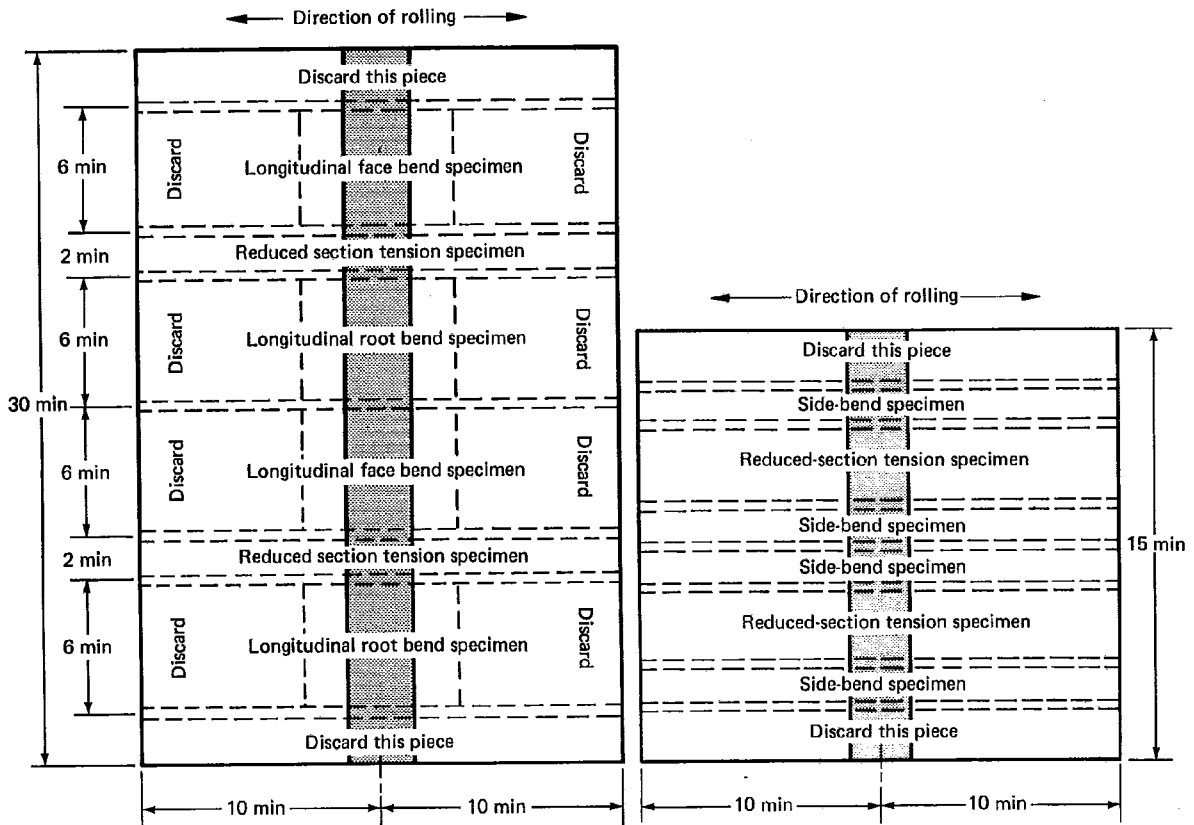

When impact tests are required, the specimens shall be removed from their locations, as shown in Fig. 18C.

(1) Longitudinal bend specimens

(2) Transverse bend specimens



The groove configuration shown is for illustration only.
The groove shape used shall conform to that being qualified.

**Fig. 16D—Location of test specimens on welded test plate over 3/8 in. thick—
procedure qualification**

66/SPECIFICATION FOR WELDING OF INDUSTRIAL & MILL CRANES

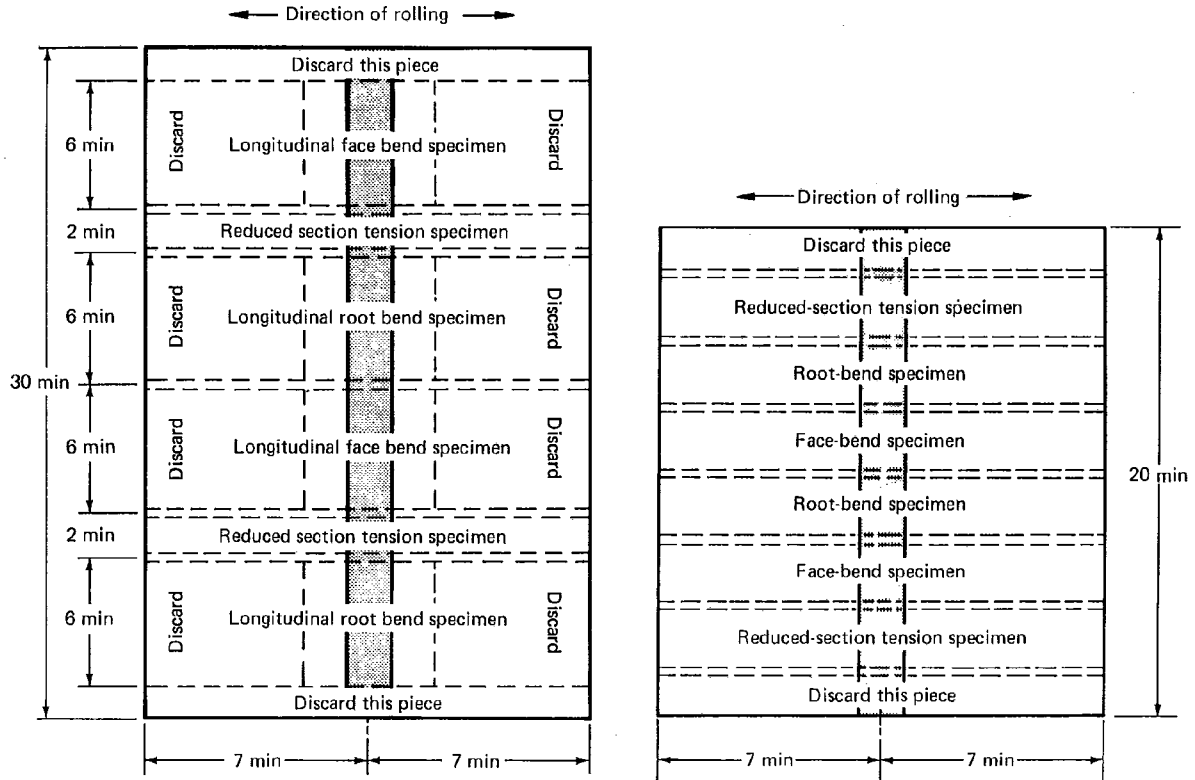

When impact tests are required, the specimens shall be removed from their locations, as shown in Fig. 18C.

(1) Longitudinal bend specimens

(2) Transverse bend specimens



The groove configuration shown is for illustration only.
The groove shape used shall conform to that being qualified.

**Fig. 16E—Location of test specimens on welded test plate 3/8 in. thick—
procedure qualification**

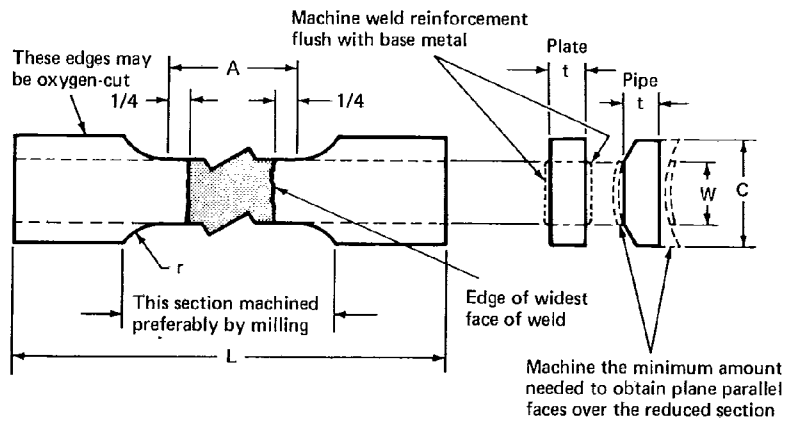

	Dimensions			Test pipe	
	Test plate			6 in. & 8 in diameter or large	
	$T_p \leq 1$ in.	$1 < T_p < 1-1/2$ in.	$T_p \geq 1-1/2$ in.	2 in. & 3 in.	
A—Length of reduced section	Widest face of weld + 1/2 in., 2-1/4 min			Widest face of weld + 1/2 in., 2-1/4 min	
L—Overall length, min (Note 2)	As required by testing equipment			As required by testing equipment	
W—Width of reduced section (Notes 3,4)	$1-1/2 \pm 0.01$	1 ± 0.01	1 ± 0.01	$1/2 \pm 0.01$	$3/4 \pm 0.01$
C—Width of grip section, min (Notes 4,5)	2	1-1/2	1-1/2	1 approx.	1-1/4 approx.
t—Specimen thickness (Notes 6,7)	T_p	T_p	T_p/n (Note 7)	Maximum possible with plane parallel faces within length A	
r—Radius of fillet, min	1/2	1/2	1/2	1	1

Notes:

1. T_p = thickness of the plate.
2. It is desirable, if possible, to make the length of the grip section large enough to allow the specimen to extend into the grips a distance equal to two-thirds or more of the length of the grips.
3. The ends of the reduced section shall not differ in width by more than 0.004 in. Also, there may be a gradual decrease in width from the ends to the center, but the width at either end shall not be more than 0.015 in. larger than the width at the center.
4. Narrower widths (W and C) may be used when necessary. In such cases, the width of the reduced section should be as large as the width of the material being tested permits. If the width of the material is less than W, the sides may be parallel throughout the length of the specimen.
5. For standard plate type specimens, the ends of the specimen shall be symmetrical with the center line of the reduced section within 0.25 in. except for referee testing, in which case the ends of the specimen shall be symmetrical with the center line of the reduced section within 0.10 in.
6. The dimension t is the thickness of the test specimen as provided for in the applicable material specifications. The minimum nominal thickness of 1-1/2 in. wide specimens shall be 3/16 in. except as permitted by the product specification.
7. For plates over 1-1/2 in. thick, specimens may be cut into the minimum number of approximately equal strips not exceeding 1-1/2 in. in thickness. Test each strip and average the results.

Fig. 17A—Reduced-section tension specimens

68/SPECIFICATION FOR WELDING OF INDUSTRIAL & MILL CRANES

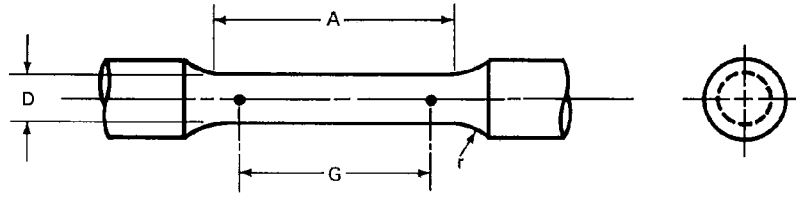

Nominal diameter	Dimensions		
	Standard specimen	Small-size specimens proportional to standard	
	0.500 in. round	0.350 in. round	0.250 in. round
G — Gage length	2.000 ± 0.005	1.400 ± 0.005	1.000 ± 0.005
D — Diameter (Note 1)	0.500 ± 0.010	0.350 ± 0.007	0.250 ± 0.005
r — Radius of fillet, min	3/8	1/4	3/16
A — Length of reduced section (Note 2), min	2-1/4	1-3/4	1-1/4

Notes:

1. The reduced section may have a gradual taper from the ends toward the center, with the ends not more than one percent larger in diameter than the center (controlling dimension).
2. If desired, the length of the reduced section may be increased to accommodate an extensometer of any convenient gage length. Reference marks for the measurement of elongation should be spaced at the indicated gage length.
3. The gage length and fillets shall be as shown, but the ends may be of any form to fit the holders of the testing machine in such a way that the load shall be axial. If the ends are to be held in wedge grips, it is desirable, if possible, to make the length of the grip section great enough to allow the specimen to extend into the grips a distance equal to two-thirds or more of the length of the grips.

Fig. 17B—All weld-metal tension specimens

tions, as shown in Fig. 18. One face of each of the three cuts shall be prepared for macroetch examination in accordance with 7.11.2.

7.10.4 Test specimens may be aged between 200° and 225° F (93°-104° C) for 46 to 50 hours when required by the filler metal specification applicable to the weld metal being tested.

7.10.5 Qualification on pipe shall also qualify for plate, but not vice versa. One exception is that qualification on plate in the 1G (flat) or 2G (horizontal) positions shall qualify for welding groove welds and fillet welds in pipe or tubing that is over 24 in. (610 mm) in diameter.

7.11 Method of Testing Specimens

7.11.1 Reduced-Section Tension Specimens. Before testing, the least width and corresponding thickness of the reduced section shall be measured. The initial cross-sectional area shall be obtained by multiplying this width by the thickness. The specimen shall be ruptured under tensile load, and the maximum load shall be determined. The tensile strength shall be obtained by dividing the maximum load by the initial cross-sectional area.

7.11.2 Macroetch Test. The weld test specimens shall be prepared with a finish suitable for macroetch examination. A suitable solution shall be used for etching to

accentuate the gross structure of the weld and any exposed internal discontinuities.

7.11.3 Root-, Face-, and Side-Bend Specimens

7.11.3.1 Each specimen shall be tested in a guided-bend test jig. Any convenient means may be used to move the plunger member with relation to the die member.

7.11.3.2 The specimen shall be placed on the die member of the jig with the weld at midspan. Face-bend and fillet-weld-soundness specimens shall be placed with the root of the weld toward the die member. Side-bend specimens shall be placed with the side showing the larger discontinuity, if any, facing the die member.

7.11.3.3 The specimen shall be forced into the die until it assumes a U-shape around the plunger. The weld and heat-affected zones must be centered and completely within the bent portion of the specimen after testing.

7.11.3.4 When using a wrap-around jig, the specimen shall be firmly clamped on one end so that it does not slide during the bending operation. The weld and heat-affected zones must be completely in the bent portion of the specimen after testing. Test specimens are to be removed from the jig after the bending roller has been moved 180 degrees from the starting point.

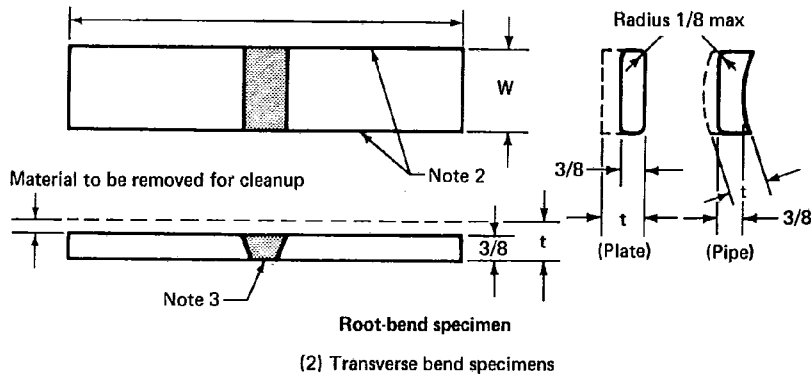
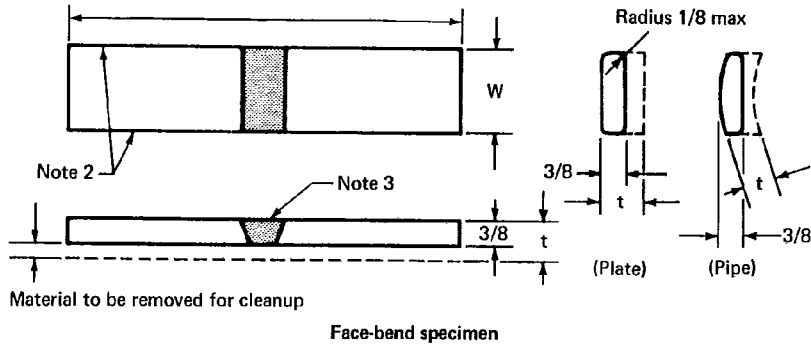
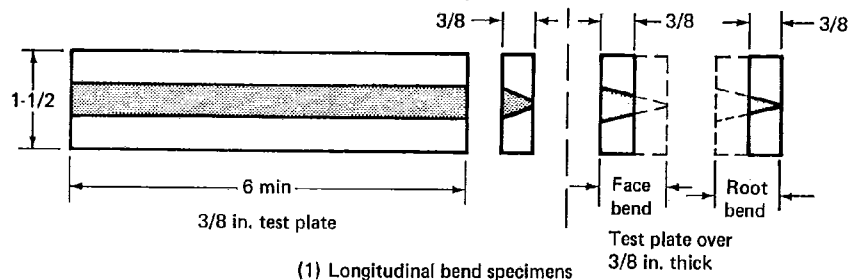

Dimensions	
Test weldment	Test specimen width, in. (W)
Plate	1-1/2
Test pipe 2 in. and 3 in. in diameter	1
Test pipe 6 in. and 8 in. in diameter	1-1/2

Notes:

1. A longer specimen length may be necessary when using a wraparound type bending fixture or when testing steel with a yield strength of 90 ksi or more.
2. These edges may be oxygen-cut and may or may not be machined.
3. The weld reinforcement and backing, if any, shall be removed flush with the surface of the specimen. If a recessed backing is used, this surface may be machined to a depth not exceeding the depth of the recess to remove the backing; in such cases, the thickness of the finished specimen shall be that specified above. Cut surfaces shall be smooth and parallel.
4. t = plate or pipe thickness.

Fig. 17C—Face- and root-bend specimens

70/SPECIFICATION FOR WELDING OF INDUSTRIAL & MILL CRANES

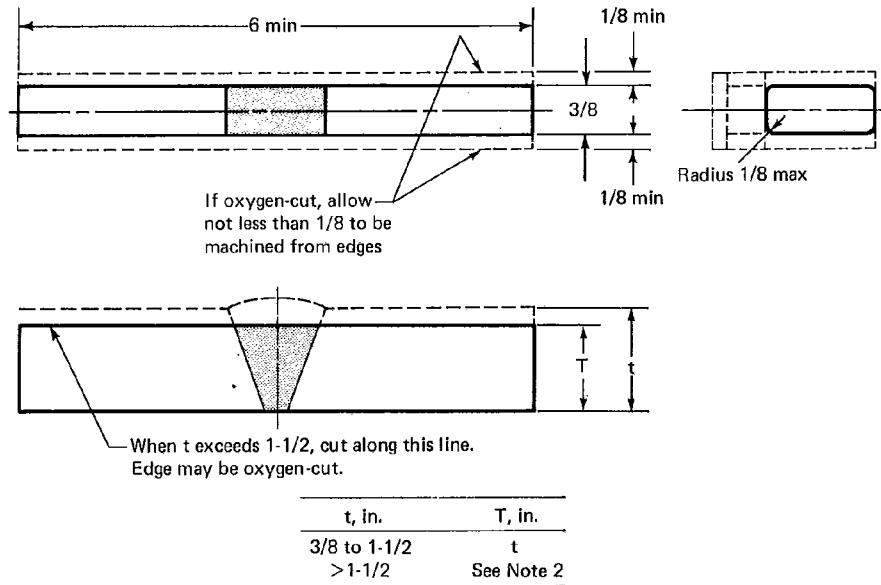

Notes:

1. A longer specimen length may be necessary when using a wraparound-type bending fixture or when testing steel with a yield point of 90 ksi or more.
2. For plates over 1-1/2 in. thick, cut the specimen into approximately equal strips with T between 3/4 and 1-1/2 in. and test each strip.
3. t = plate or pipe thickness.

Fig. 17D—Side-bend specimens

7.11.4 All-Weld-Metal Tension Test. The test specimen shall be tested in accordance with AWS B4.0, *Standard Methods for Mechanical Testing of Welds*, latest edition.

7.11.5 Radiography. The radiographic procedure and technique shall be in accordance with the requirements of Section 8.

7.11.6 Ultrasonic Testing. The ultrasonic procedure and technique shall be in accordance with the requirements of Section 8.

7.12 Test Results Required

7.12.1 Reduced-Section Tension Test. The tensile strength must not be less than the minimum of the specified tensile range of the base metal.

7.12.2 Root-, Face-, and Side-Bend Tests. The convex surface of the specimen shall be examined for the appearance of cracks or other open discontinuities. A specimen shall be considered as failed when a crack or other open discontinuity exceeding 1/8 in. (3 mm), measured in any direction, is present after the bending. Cracks occurring on the corners of the specimen during testing shall not be considered.

7.12.3 Macroetch Tests. The macroetched surfaces of the specimens shall be examined for discontinuities, and the welds shall be considered as failed when discontinuities prohibited by 8.6 are observed on the macroetched surfaces. Partial-joint-penetration groove welds must have the designated effective throat. Fillet welds must show fusion to the root of the joint, but not necessarily beyond, and both legs must be equal to within 1/8 in. (3 mm). Convexity must not exceed the limits specified in 8.7.

7.12.4 All-Weld-Metal Tension Test (Electroslag and Electroglas). The mechanical properties must equal or exceed those specified in Table 11.

7.12.5 Nondestructive Testing. The weld soundness, as revealed by either radiographic or ultrasonic testing, must conform to the requirements of Section 8.

7.12.6 Visual Inspection — Pipe and Tubing. For acceptable qualification, a pipe weld must conform to the following requirements when inspected visually.

7.12.6.1 The weld must be free of cracks.

7.12.6.2 All craters must be filled to the full cross section of the weld.

7.12.6.3 The face of the weld must be at least flush with the outside surface of the pipe, and the weld must blend smoothly with the base metal. Undercut must not exceed 1/64 in. (0.4 mm). Weld reinforcement must not exceed values given in Table 13.

7.12.6.4 The root of the weld shall be inspected. There must be no evidence of cracks, incomplete fusion, or inadequate joint penetration. A concave root surface is permitted within the limits shown in 7.12.6.5, provided the total weld thickness is equal to, or greater than, that of the base metal.

7.12.6.5 The root surface concavity must be 1/16 in. (1.6 mm), or less, and the melt-through must be 1/8 in. (3 mm) or less.

7.12.7 Visual Inspection-Plate. For acceptable qualification, the welded test plate, when inspected visually, must conform to the requirements for visual inspection in Section 8.

7.13 Records. Records of the test results shall be kept by the manufacturer or contractor, and shall be available to those authorized to examine them.

7.14 Retests. If any one tested specimen fails to meet the test requirements, two retests of that particular type of test specimen may be performed with specimens cut from the same procedure qualification test material. The results of both retest specimens must meet the test requirements.

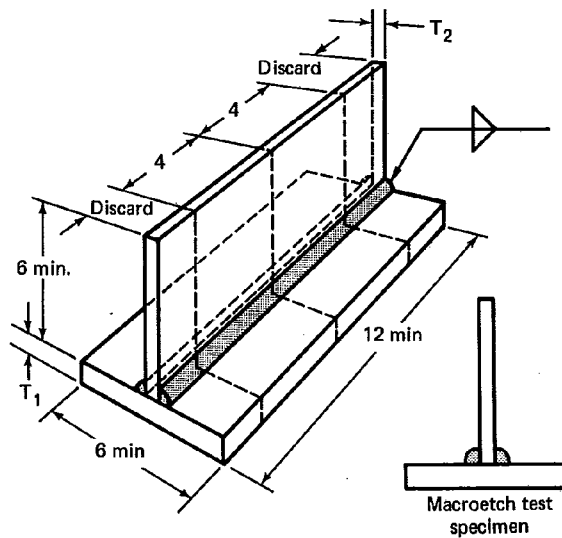

Weld size	T ₁ min*	T ₂ min*
3/16	1/2	3/16
1/4	3/4	1/4
5/16	1	5/16
3/8	1	3/8
1/2	1	1/2
5/8	1	5/8
3/4	1	3/4
>3/4	1	1

*Note: Where the maximum plate thickness used in production is less than the value shown in the table, the maximum thickness of the production pieces may be substituted for T₁ and T₂.

Fig. 18—Fillet weld soundness test for procedure qualification

72/SPECIFICATION FOR WELDING OF INDUSTRIAL & MILL CRANES

Table 13
Acceptable reinforcement on groove welds
in pipe tubing

Wall thickness,		Maximum reinforcement,	
in.	mm	in.	mm
3/8 or less	9.5	3/32	2
Over 3/8 to 3/4	10-19	1/8	3
Over 3/4	19	3/16	5

For material over 1.5 in. (38 mm) thick, failure of a specimen shall require testing of all specimens of the same type from two additional locations in the test material.

Part C

Performance Qualification

7.15 General. The qualification tests described are specially devised to determine a welder's ability to produce sound welds. These tests are not intended to be used as a guide for welding during actual construction. Welding during manufacturing shall be performed in accordance with the requirements of the procedure specification.

7.16 Limitations. For the qualification of welders, the following rules shall apply:

7.16.1 Qualification established with any one of the steels permitted by this specification shall be considered as qualification to weld or tack weld any of the other steels.

7.16.2 A welder shall be qualified for each process used.

7.16.3 A welder qualified for shielded metal arc welding with an electrode identified in Table 14 shall be considered qualified to weld, or tack weld, with any other

electrode in the same group designation, and with any electrode listed in a numerically lower group designation.

7.16.4 A welder qualified with an approved electrode-shielding medium combination shall be considered qualified to weld or tack weld with any other approved electrode-shielding medium combination for the process used in the qualification test.

7.16.5 A change in the position of welding in which the welder is not qualified to weld shall require qualification in that position.

7.16.6 A change from one diameter-thickness grouping of pipe to another grouping shall require requalification.

7.16.7 A change in the direction of welding shall require requalification when the plate is in the vertical position, or the pipe or tubing is in the 5G or 6G position.

7.16.8 The omission of backing material in complete-joint-penetration welds that are welded from one side shall require requalification.

7.17 Qualification Tests Required

7.17.1 The welder qualification tests for manual and semiautomatic welding of plate shall be as follows:

(1) Groove weld qualification test plate of unlimited thickness

(2) Groove weld qualification test for plate of limited thickness

Table 14
Grouping of shielded metal arc welding electrodes
for performance qualification

Group designation	AWS electrode classification ^a
F4	EXX15, EXX16, EXX18
F3	EXX10, EXX11
F2	EXX12, EXX13, EXX14
F1	EXX20, EXX24, EXX27, EXX28

Note:

a. The letters "XX" used in the classification designation stand for the strength level (60, 70, 80, 90, 100, 110, or 120) or deposited weld metal.

(3) Fillet weld qualification test for fillet welds only, Option 1 or 2 (see 7.22)

7.17.2 The pipe or tubing qualification tests for manual and semiautomatic welding shall be as follows:

(1) Groove weld qualification test for butt joints in pipe or square or rectangular tubing

(2) Groove weld qualification test for T-, K-, or Y-connections in pipe or square or rectangular tubing

(3) Groove weld qualification test on flat plate for butt joints in square or rectangular tubing

7.17.3 A welder who makes a successful procedure qualification test of a complete-joint-penetration groove weld in flat plate is qualified to weld production plate and square or rectangular tubing equal to or less than the thickness of the welded test plate with the welding process and in the position used in the test. If the test plate is 1 in. (25 mm) or greater in thickness, the welder is qualified for all thicknesses. The welder is also qualified to make

fillet welds in plate and pipe, as shown in Table 15.

7.17.4 The welder who makes a successful procedure qualification test of a complete-joint-penetration groove weld in pipe without a backing strip is qualified to weld pipe and tubing with the processes used in the test. This qualification will include welding in the position tested pipe having a wall thickness equal to or less than that of the test pipe. If the welded test pipe was 6 in. Sch. 80 or 8 in. Sch. 120 size, the welder is qualified for all thicknesses. If the diameter of job-size pipe or tubing used for qualification is 4 in. (102 mm) or less, the qualification is limited to diameter of 3/4 in. (19 mm) through 4 in. (102 mm) inclusive. If the diameter is over 4 in. (102 mm), the qualification is limited to diameters of greater than one-half the test pipe diameter or 4 in. (102 mm), whichever is larger. The wall thickness qualified and the number of test specimens required shall be the same as specified for the equivalent pipe size in Table 16.

Table 15
Welder qualification-type and position limitations

Qualification test	Plate or pipe positions	Type of weld and position of welding qualified*			
		Plate		Pipe	
Weld		Groove	Fillet	Groove	Fillet
Plate-groove (Note 1)	1G	F	F, H	F	(Note 2) F, H
	2G	F, H	F, H	F, H	(Note 2) F, H
	3G	F, H, V	F, H, V		F, H
	4G	F, OH	F, H, OH		F
	3G & 4G	All	All		F, H
Plate-fillet (Notes 1 and 3)	1F		F		F
	2F		F, H		F, H
	3F	F, H, V			
	4F	F, H, OH			
	3F & 4F	All			
Pipe-groove	1G	F	F, H	F	F, H
	2G	F, H	F, H	F, H	F, H
	5G	F, V, OH	F, V, OH	F, V, OH	F, V, OH
	6G	Note 4	Note 4	Note 4	Note 4
	2G & 5G	Note 4	Note 4	Note 4	Note 4
	6GR	All	All	All	All

Notes:

- Not applicable for welding operator qualification.
- Welding operators qualified to weld pipe or tubing over 24 in. (600 mm) in diameter for the test positions indicated.
- Not applicable for fillet welds between parts having a dihedral angle of 75 degrees or less.
- Qualifies for all but groove welds for T-, Y-, and K-connections.

*Positions of welding: F=flat, H=horizontal, V=vertical, OH=overhead

74/SPECIFICATION FOR WELDING OF INDUSTRIAL & MILL CRANES

Table 16
Number and type of test specimens and range of thickness qualified —
welding and welding operator qualification

1. Tests on plate

Type of weld	Thickness of test plate (T) as welded, in.	Visual inspection	Number of specimens					Macro-etch test	Plate thickness qualified, in.
			Bend tests*			T-joint break			
			Face	Root	Side				
Groove**	3/8	Yes	1	1	—	—	—	3/4 max ^c	
Groove	3/8 < T < 1	Yes	—	—	2	—	—	T/2-2T ^{c,d}	
Groove	1 or over	Yes	—	—	2	—	—	Unlimited ^c	
Fillet option No. 1 ^a	1/2	Yes	—	—	—	1	1	Unlimited	
Fillet option No. 2 ^b	3/8	Yes	—	2	—	—	—	Unlimited	

Notes:

(a) See Fig. 23.

(b) See Fig. 24.

(c) Also qualifies for welding fillet welds on material of unlimited thickness.

(d) T max for welding operator qualification.

*Radiographic examination of the welder or welding operator test plate may be made in lieu of the bend test. (See 7.3.2)

**Not applicable for welding operator qualification.

2. Tests on pipe or tubing

Type of weld	Pipe or tubing size, as welded		Visual Inspection	Number of specimens						Pipe or tube size qualified, in.	Pipe or tube wall thickness qualified, in.	
	Diam	Thickness		All positions except 5G and 6G			5G & 6G positions only				min	max ^a
				Face bend	Root bend	Side bend	Face bend	Root bend	Side bend			
Groove	2 in.	Sch. 80	Yes	1	1	—	2	2	—	4 or smaller	0.063	0.674
	3 in.	Sch. 40										
Groove	6 in.	Sch. 80	Yes	—	—	2	—	—	4	Larger than 4	0.187	Unlimited
	8 in.	Sch. 120										
Groove	See Fig. 22		Yes	—	—	—	—	—	4	T-, K-, and Y-connections	Unlimited	
Job size pipe or tubing												
	Diam	Wall thickness										
Groove	< 4 in.	Any	Yes	1	1	—	2	2	—	3/4 through 4	0.063	0.674
Groove	< 4 in.	Any	Yes	—	—	2	—	—	4	1/2 test diam or 4 min ^(b)	0.187	Unlimited

Note: Radiographic examination of the welder or welding operator test pipe may be made in lieu of the bend test. (See 7.3.2).

1. Also qualifies for welding fillet welds of material of unlimited thickness.

2. Minimum pipe size qualified shall not be less than 4 in. or 1/2d, whichever is greater, where d is diameter of test pipe.

(Continued)

Table 16 (continued)

3. Tests on electroslag and electrogas welds

Plate thickness tested,	Number of sample welds	Test specimens required		Plate thickness qualified, in.
		Visual Inspection	Side bend	
1-1/2 max	1	Yes	2	Unlimited for 1-1/2 Max tested for <1-1/2

Note: Radiographic of test plate may be made in lieu of the bend test. (See 7.3.2).

7.18 Groove Weld Plate Qualification Test for Plate of Unlimited Thickness. The joint detail shall be as follows: 1 in. (25 mm) plate, single-V-groove, 45 degree included angle, 1/4 in. (6 mm) root opening with backing (see Fig. 19A). For horizontal position qualification, the joint detail may, at the contractor's option, be a single bevel groove, 45 degree groove angle, 1/4 in. (6 mm) root opening with backing (see Fig. 19B). Backing must be at least 3/8 in. (9.5 mm) x 3 in. (76 mm) if radiographic testing is used without prior removal of backing. It must be at least 3/8 in. x 2 in. (9.5 mm x 51 mm) for mechanical and ultrasonic testing, and for radiographic testing after the backing is removed. Minimum length of welding groove shall be 5 in. (127 mm).

7.19 Groove Weld Plate Qualification Test for Plate of Limited Thickness. The joint detail shall be as follows: 3/8 in. (9.5 mm) plate, single V-groove, 45 degree included angle, 1/4 in. (6 mm) root opening with backing (see Fig. 20A). For horizontal position qualification, the joint detail may, at the contractor's option, be single bevel groove, 45 degree groove angle, 1/4 in. (6 mm) root opening with backing (see Fig. 20B). Backing must be at least 3/8 in. x 3 in. (9.5 mm x 76 mm) if radiographic testing is used without prior removal of the backing. It must be at least 3/8 in. x 2 in. (9.5 mm x 51 mm) for mechanical testing or for radiographic or ultrasonic testing after the backing is removed. Minimum length of welding groove shall be 5 in. (127 mm).

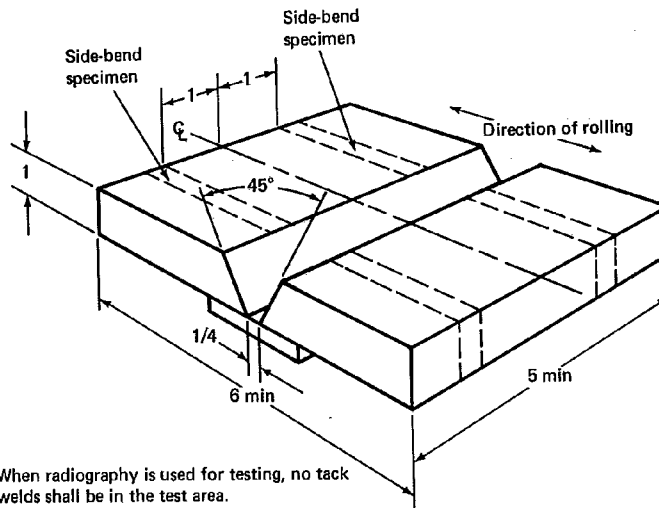
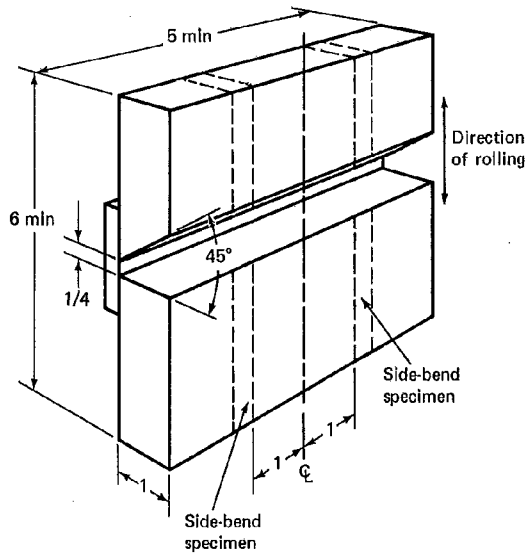

Fig. 19A—Test plate for unlimited thickness—welder qualification

76/SPECIFICATION FOR WELDING OF INDUSTRIAL & MILL CRANES



Note: When radiography is used for testing, no tack welds shall be in the test area.

Fig. 19B—Optional test plate for unlimited thickness—horizontal position—welder qualification

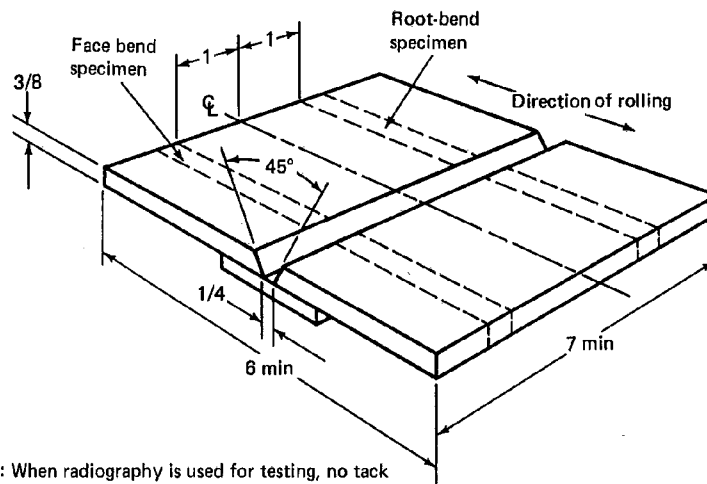

Note: When radiography is used for testing, no tack welds shall be in the test area.

Fig. 20A—Test plate for limited thickness—all positions—welder qualification

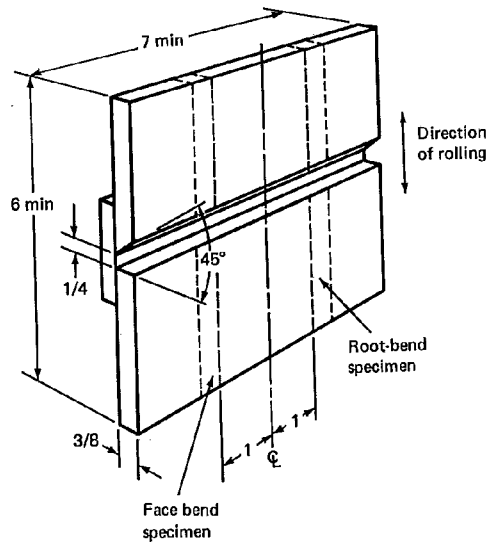

Note: When radiography is used for testing, no tack weld welds shall be in the test area.

Fig. 20B—Optional test plate for limited thickness—horizontal position—welder qualification

7.20 Groove Weld Qualification Test for Butt Joints in Pipe or Tubing. The joint detail shall be that shown in a qualified welding procedure specification for a single-welded pipe butt joint. Alternatively, the joint may be prepared in job-sized pipe with a single V-groove, 60 degree included angle, 1/8 in. (3 mm) maximum root face and root opening without backing strip (see Fig. 21A), or a single V-groove, 60 degree included angle, and suitable root opening with backing (see Fig. 21B).

7.21 Groove Weld Qualification Test for T-, Y-, and K-Connections on Pipe or Tubing. The test joint design is shown in Fig. 22. The joint detail shall be as follows: single bevel groove, 37-1/2 degree included angle, 1/16 in. (1.5 mm) maximum root face, 1/8 in. (3 mm) root opening with the bevel on a pipe or tube that is at least 1/2 in. (13 mm) thick. The square edge pipe or tube shall be at least 1/16 in. (1.5 mm) thicker than the beveled pipe. A restriction ring shall be placed on the thicker pipe within 1/2 in. (13 mm) of the joint, and shall extend at least 6 in. (152mm) beyond the surface of the pipe or tube (see Fig. 22). Test specimens for side bends shall be taken and machined as standard specimens with parallel sides.

7.22 Fillet Weld Qualification Test. For fillet weld qualification only, the welder shall weld a test plate according to Option 1 or Option 2, depending on the contractor's choice, as follows:

- (1) Option 1—Weld a T-test plate in accordance with Fig. 23.
- (2) Option 2—Weld a soundness test plate in accordance with Fig. 24.

7.23 Position of Test Welds. The positions shall be as listed in Table 15.

7.23.1 Groove Plate Test Welds

7.23.1.1 Qualification in the 1G (flat) position qualifies the welder for (1) flat-position groove welding of plate, pipe, and tubing, (2) flat- and horizontal-position fillet welding of plate, and (3) flat-position fillet welding of pipe and tubing.

7.23.1.2 Qualification in the 2G (horizontal) position qualifies the welder for flat- and horizontal-position groove welding, and flat- and horizontal- position fillet welding of plate, pipe, and tubing.

7.23.1.3 Qualification in the 3G (vertical) position qualifies the welder for flat-, horizontal-, and vertical-

78/SPECIFICATION FOR WELDING OF INDUSTRIAL & MILL CRANES

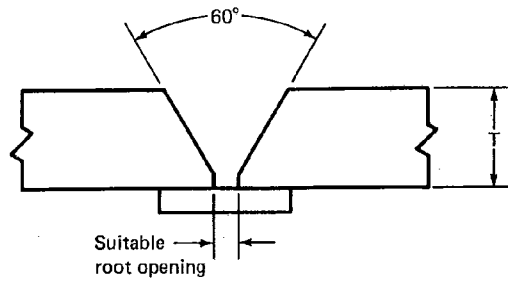

Fig. 21A—Plate and pipe butt joint—welder qualification—without backing

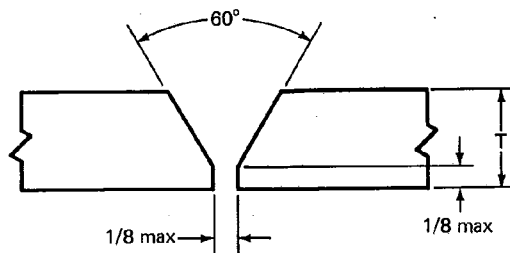

Fig. 21B—Pipe test butt joint—welder qualification—with backing

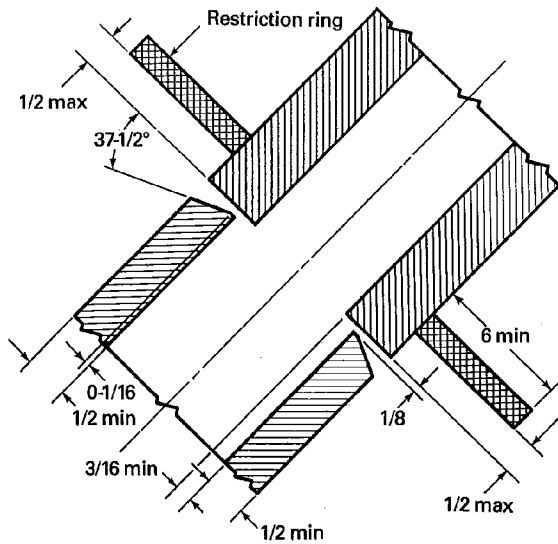

Fig. 22—Test joint for T-, K-, and Y-connections on pipe or square or rectangular tubing—welder qualification

position groove welding, and flat-, horizontal-, and vertical-position fillet welding of plate.

7.23.1.4 Qualification in the 4G (overhead) position qualifies the welder for flat- and overhead-position groove welding, and flat-, horizontal-, and overhead-position fillet welding of plate.

7.23.2 Groove Pipe Test Welds

7.23.2.1 Qualification in the 1G (pipe horizontal, rolled) position qualifies the welder for (1) flat-position groove welding of pipe, tubing, and plate, (2) flat-position fillet welding of pipe and tubing, and (3) flat- and horizontal- position fillet welding of plate.

7.23.2.2 Qualification in the 2G (pipe vertical) position qualifies the welder for flat- and horizontal-position groove welding and flat- and horizontal-position fillet welding of pipe, tubing, and plate.

7.23.2.3 Qualification in the 5G (pipe horizontal, fixed) position qualifies the welder for flat-, vertical-, and overhead-position groove welding and flat-, vertical-, and overhead-position fillet welding of pipe, tubing, and plate.

7.23.2.4 Qualification in the 6G (inclined, fixed) position qualifies the welder for all-position groove and all-position fillet welding of pipe, tubing, and plate.

7.23.2.5 Qualification for T-, K-, or Y-connections in the 6GR (inclined, fixed) position qualifies the welder for groove welding of T-, K-, or Y-connections, and for groove and fillet welding of pipe, tubing, and plate in all positions.

7.23.3 Fillet Weld Test

7.23.3.1 Qualification in the 1F (flat) position qualifies the welder for flat-position fillet welding of plate, pipe, and tubing.

7.23.3.2 Qualification in the 2F (horizontal) position qualifies the welder for flat-, and horizontal-position fillet welding of plate, pipe, and tubing.

7.23.3.3 Qualification in the 3F (vertical) position qualifies the welder for flat-, horizontal-, and vertical-position fillet welding of plate.

7.23.3.4 Qualification in the 4F (overhead) position qualifies the welder for flat-, horizontal-, and overhead-position fillet welding of plate.

7.24 Base Metal. The base metal used shall comply with the procedure specification.

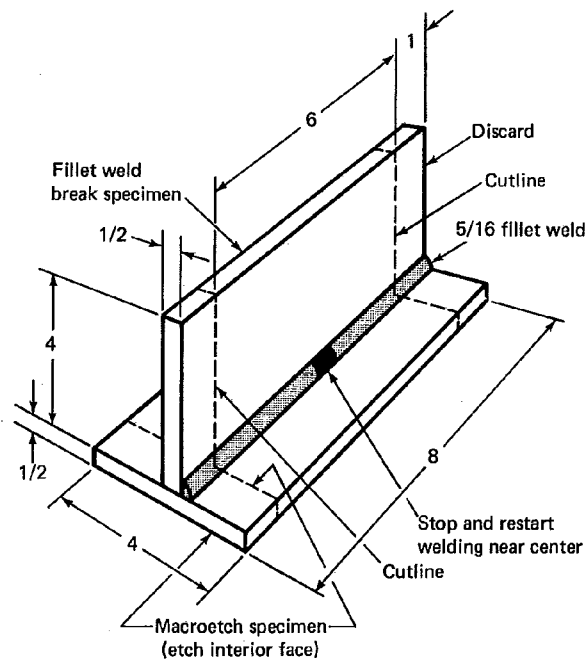

Note: Plate thickness and dimensions are minimum.

Fig. 23—Fillet weld-break and macroetch test plate—welder qualification—Option 1

80/SPECIFICATION FOR WELDING OF INDUSTRIAL & MILL CRANES

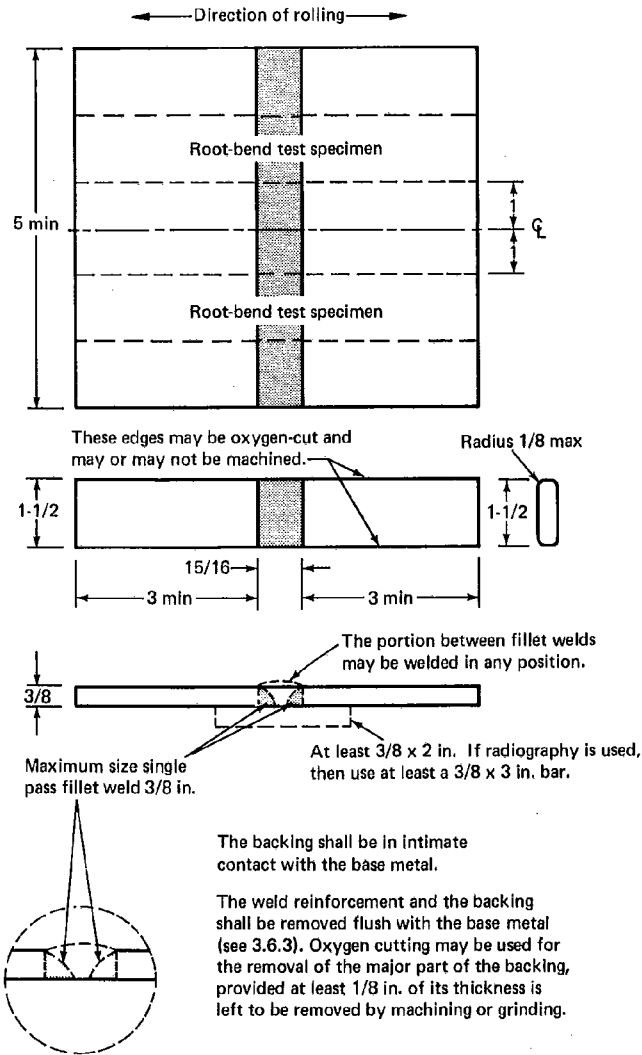

Fig. 24—Fillet weld root-bend test plate—welder qualification—Option 2

7.25 Joint Welding Procedure

7.25.1 The welder shall follow a joint welding procedure specification applicable to the joint details given in 7.18, 7.19, 7.20, 7.21, or 7.22, whichever is applicable. For complete-joint-penetration groove welds that are welded from one side without backing, the welder shall follow a welding procedure specification applicable to the joint detail shown in Fig. 21A.

7.25.2 Weld cleaning shall be done with the test weld in the same position as the welding position being qualified.

7.26 Test Specimens

7.26.1 The type and number of test specimens that must be tested to qualify a welder by mechanical testing are given in Table 16. The range of thickness that can be welded in construction, which depends on the thickness of the test plate, is also given in the table. Radiographic or ultrasonic examination of the test weld may be used in lieu of mechanical testing at the contractor's option.

7.26.2 Guided-bend test specimens shall be prepared by cutting the test plate, pipe, or tubing as shown in Figs.

19A and B, 20A and B, 24 or 25, whichever is applicable, to form specimens approximately rectangular in cross section. The specimens shall be prepared for testing in accordance with Figs. 17A through D, whichever is applicable.

7.26.3 The fillet weld break and macroetch test specimens shall be cut from the test joint as shown in Fig. 23. The exposed section of the macroetch test specimen shall be smoothed for etching.

7.26.4 The weld reinforcement need not be ground or otherwise smoothed for inspection when radiographic testing is used in lieu of the prescribed bend tests, unless surface irregularities or juncture with the base metal would cause objectionable weld discontinuities to be obscured

in the radiograph. If the backing is removed for radiographic testing, the root shall be ground flush with the base metal (see 8.7.3).

7.27 Method of Testing Specimens

7.27.1 Root-, Face-, and Side-Bend Specimens. Each specimen shall be bent in a jig having the contour shown in Fig. 26A, and otherwise substantially in accordance with that figure. The plunger member may be moved with relation to the die member of any convenient means.

The specimen shall be placed on the die member of the jig with the weld at midspan. Face-bend specimens shall be placed with the face of the weld toward the die member. Root-bend and fillet weld Option No. 2 soundness

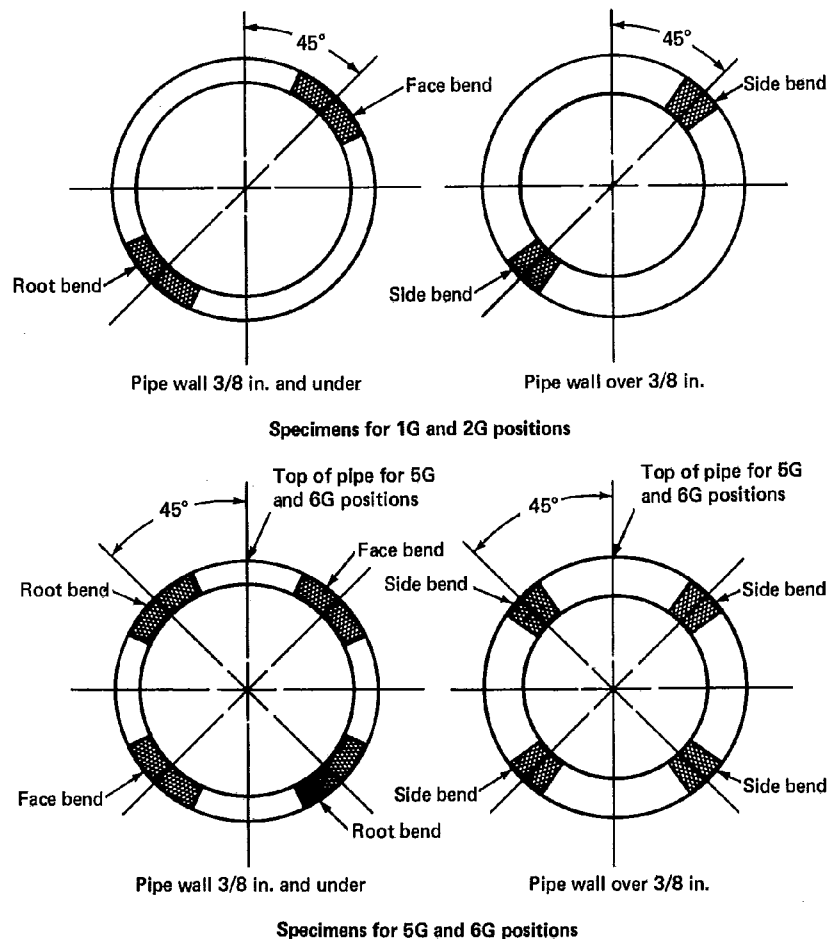

Fig. 25--Location of test specimens on welded test pipe-welder qualification

82/SPECIFICATION FOR WELDING OF INDUSTRIAL & MILL CRANES

specimens shall be placed with the root of the weld toward the die member. Side-bend specimens shall be placed with that side showing the greater discontinuity, if any, toward the die member.

The specimen shall be forced into the die until the specimen assumes a U-shape of the plunger. The weld and heat-affected zones shall be centered and proportioned completely within the bent portion of the specimen.

When using a wraparound jig, the specimen shall be firmly clamped on one end so that the specimen does not slide during the bending operation. The weld and heat-affected zones must be completely within the bent portion of the specimen after testing. Test specimen is removed from the jig after the outer roll has been moved 180 degrees from the starting point.

7.27.2 Fillet Weld Break Test (Option No. 1). The

entire length of the fillet weld shall be examined visually. Then the 6 in. (152 mm) long specimen shall be cut from the sample and loaded in such a way that the root of the weld is in tension. The load shall be steadily increased or repeated until the specimen fractures or bends flat upon itself.

7.27.3 Macroetch Test (Fillet Option No. 1). The test specimens shall be suitably smoothed for macroetch examination. A suitable solution shall be used for etching to give a clear definition of the weld.

7.27.4 Radiographic. The radiographic procedure and technique shall be in accordance with the requirements of Section 8. Only the center 50 percent of the test plate length or of the test pipe weld shall be subject to examination.

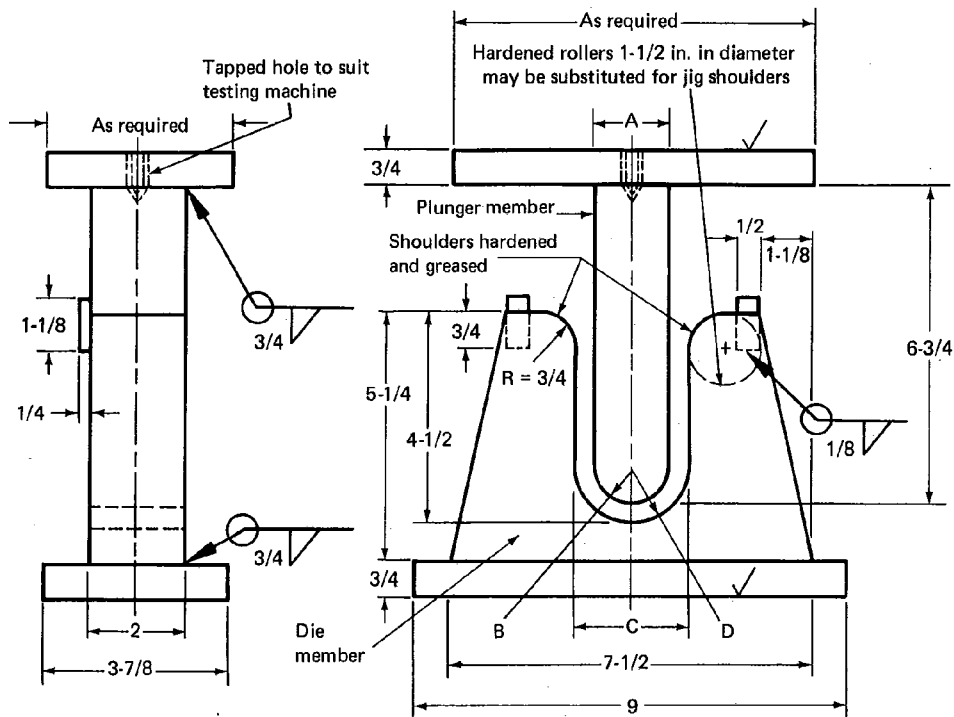

Minimum specified material yield strength, psi	A in.	B in.	C in.	D in.
50 000 & under	1-1/2	3/4	2-3/8	1-3/16
Over 50 000 to 90 000	2	1	2-7/8	1-7/16
90 000 & over	2-1/2	1-1/4	3-3/8	1-11/16

Note: Plunger and interior die surfaces shall be machine-finished.

Fig. 26A—Guided-bend test jig

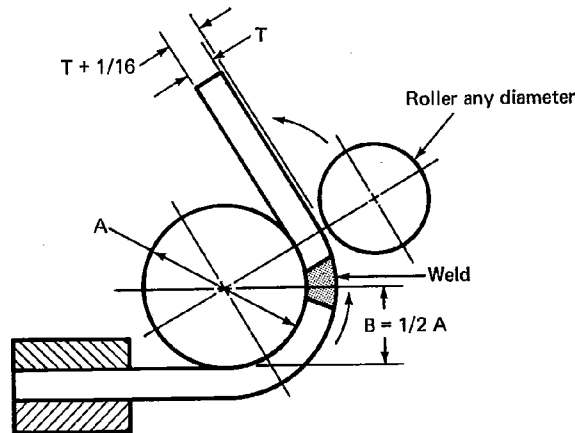

Minimum specified material yield strength, psi	A in.	B in.
50 000 & under	1-1/2	3/4
Over 50 000 to 90 000	2	1
90 000 & over	2-1/2	1-1/4

Fig. 26B—Alternative wraparound guided-bend test jig

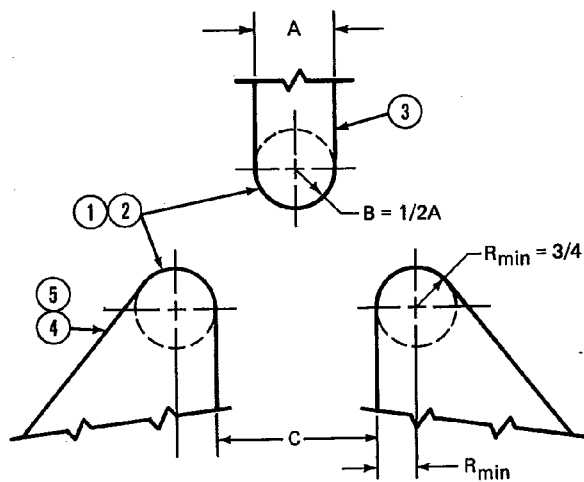

Minimum specified material yield strength, psi	A in.	B in.	C in.
50 000 & under	1-1/2	3/4	2-3/8
Over 50 000 to 90 000	2	1	2-7/8
90 000 & over	2-1/2	1-1/4	3-3/8

Fig. 26C—Alternative roller-equipped guided-bend test jig for bottom ejection of test specimen

84/SPECIFICATION FOR WELDING OF INDUSTRIAL & MILL CRANES

7.27.5 Ultrasonic Test. The ultrasonic procedures and technique shall be in accordance with Section 8.

7.28 Test Results Required

7.28.1 Root-, Face-, and Side-Bend Tests. The convex surface of the bent specimen shall be examined visually for discontinuities. Any bent specimen in which a crack or other open discontinuity exceeding 1/8 in. (3 mm) in any direction is present shall be considered as having failed. Cracks occurring on the corners of the specimen during testing shall be disregarded.

7.28.2 Fillet Weld Break Test

7.28.2.1 To pass visual examination, the fillet weld shall present a reasonably uniform appearance and must be free of overlap, cracks, and excessive undercut. There must be no porosity visible on the surface of the weld.

7.28.2.2 The fillet weld specimen passes the test if it bends flat upon itself. If the fillet weld fractures, the fractured surface must show complete fusion to the root of the joint, and exhibit no inclusion or porosity larger than 3/32 in. (2.4 mm) in greatest dimension to pass the test. The sums of the greatest dimensions of all inclusions and porosity at the fractured surface must not exceed 3/8 in. (10 mm) in the 6 in. (152 mm) long specimen.

7.28.3 Macroetch Test. The specimen shall be examined for discontinuities. If discontinuities prohibited by Section 8 are found, the test shall be considered as failed. The weld must show fusion to the root, but not necessarily beyond, and both legs must be equal to within 1/8 in. (3 mm). Convexity must not exceed the limits specified in 8.7; e.g., 1/16 in. (1.6 mm) for a 5/16 in. (8 mm) test weld.

7.28.4 Radiographic Test. To qualify, the weld, as revealed by the radiograph, must conform to the requirements of Section 8.

7.28.5 Ultrasonic Test. The weld, as revealed by ultrasonic inspection, must conform to the requirements of Section 8.

7.28.6 Visual Inspection of Pipe and Tubing. To qualify, the pipe weld must conform to the following requirements:

- (1) Be free of cracks.
- (2) All craters must be filled to the full cross section of the weld.
- (3) The face of the weld must be at least flush with the outside surface of the pipe, and the weld must be at least flush with the outside surface of the pipe, and the weld must merge smoothly with the base metal. Undercut must not exceed 1/64 in. (0.4 mm). Weld reinforcement must not exceed that permitted in Table 13.
- (4) The root of the weld shall be inspected, and there must be no evidence of cracks, incomplete fusion, or inadequate joint penetration. A concave root surface is

permitted within the limits of 7.28.6(5), provided the total weld thickness is equal to or greater than that of the base metal.

(5) The root surface concavity must be 1/16 in. (1.6 mm) or less, and the melt-through must be 1/8 in. (3 mm) or less.

7.28.7 Visual Inspection of Plate. For acceptable qualification, the welded test plates shall conform to the requirements for visual inspection in 8.6.

7.29 Retests. If one or more test welds made by a welder fails to meet the requirements, a retest may be allowed under the following conditions:

(1) An immediate retest may be made consisting of two welds of each type on which the welder failed. The retest specimens must meet all the specified requirements.

(2) A retest may be made, provided there is evidence that the welder has had further training or practice. In this case, one complete retest shall be made.

7.30 Period of Effectiveness. The welder's qualification, as specified, shall remain in effect indefinitely unless (1) the welder is not engaged in a given process of welding for which the welder is qualified for a period exceeding 6 months or (2) there is some specific reason to question the welder's ability. In case (1), the requalification test need be made only in the 3/8 in. (9.5 mm) thickness.

7.31 Records. Records of the test results shall be kept by the manufacturer or contractor and shall be available to those authorized to examine them.

7.32 Workmanship Qualification

7.32.1 Scope. The tests described herein are a second method of welder qualification for welders performing operations on secondary stressed components and non-critical weldments. Workmanship samples, as shown in Figs. 27(A) and (B), or a sample similar to the production welds must be made.

7.32.2 Welder Qualification. Qualification tests are used to determine a welder's ability to produce sound, acceptable welds when welding to the requirements of a qualified procedure specification using a manually-directed welding process. The type and number of samples to be made shall be determined by the manufacturer to represent the type of work the welder will be doing. The test shall be witnessed, evaluated, and recorded by personnel authorized by the manufacturer to do so, using visual inspection and appropriate sectioning and etching of each sample. The welds shall meet the requirements of Sections 5 and 8.

7.32.3 Production Qualification. After successful completion of one or more workmanship samples, the

capability of the welder to satisfactorily perform production welding will be determined after a try-out at the job station. Qualification shall be achieved when the welder produces a typical production part that meets the quality requirements of this specification, as witnessed and recorded by personnel authorized by the manufacturer to do so.

7.32.4 Sample Examination. Methods of examining samples shall be visual, sectioning and etching, and physical measurement.

7.32.4.1 Visual Examination. To pass the visual examination, the welds must meet the requirements of Sections 5 and 8.

7.32.4.2 Macroetch Examination. The specimen cross section shall be smoothed, etched, and examined

for discontinuities. The sample must meet the applicable requirements in other sections of this specification. The weld must show complete fusion to the root, but not necessarily beyond. Convexity and concavity of the weld must not exceed the limits specified in Sections 5 and 8.

7.32.4.3 Physical Measurement Examination. Welds shall be measured to ascertain that they meet the size tolerances specified in Sections 5 and 8.

7.32.5 Retests. In case one or more test welds, fail to meet the requirements of 7.32.4, the welder may be retested under the following conditions:

(1) An immediate retest may be made that shall consist of two test welds of each type that failed. Both test specimens must meet all the requirements specified for such welds.

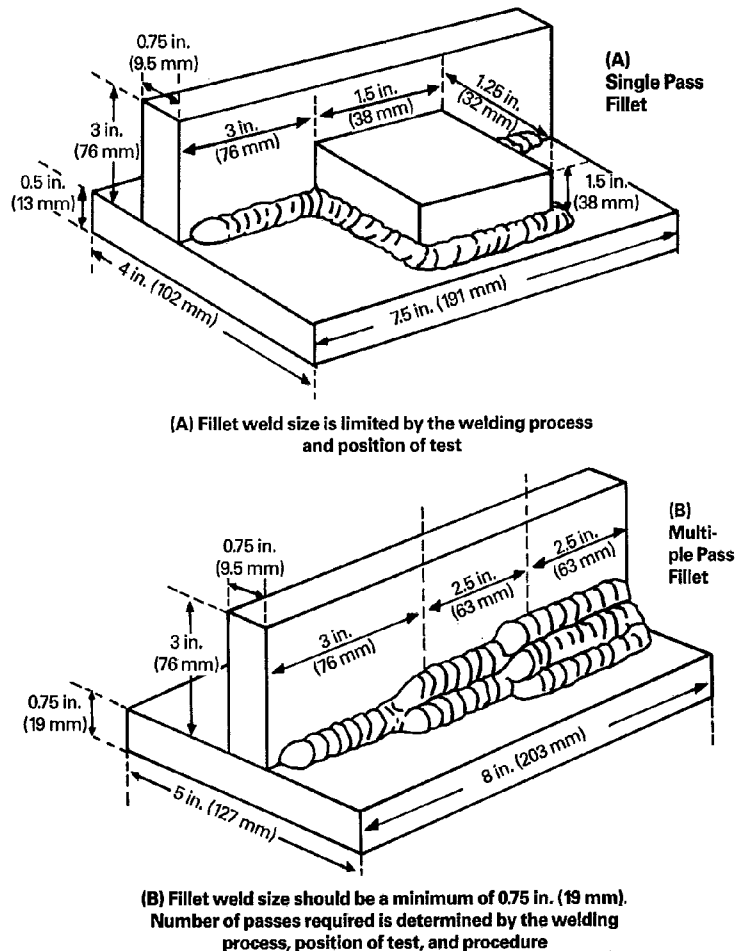

Fig. 27—Examples of workmanship samples

86/SPECIFICATION FOR WELDING OF INDUSTRIAL & MILL CRANES

(2) A retest may be made provided there is evidence that the welder has had further training or practice. In this case, one complete retest shall be made.

7.32.6 Period of Effectiveness. Welder qualification verified by workmanship samples shall remain in effect indefinitely unless (1) the welder does not use a welding process for which he is qualified for a period exceeding six months or (2) there is some specific reason to question the welder's ability. In case (1), the requalification test need be made only in 3/8 in. (9.5 mm) thick material.

7.32.7 Records. Records of the test results shall be kept by the manufacturer, and shall be available to those authorized to examine them (see suggested sample form in Appendix A).

Part D

Welding Operator Qualification

7.33 General The qualification tests described in this section are specially devised to determine a welding operator's ability to produce sound welds. The tests are not intended to be used as a guide for welding during actual construction. The latter shall be performed in accordance with the requirements of the procedure specification. For an alternate method of qualification, see 7.32.

7.34 Limitations. For the qualification of a welding operator, the following rules shall apply:

(1) Qualification established with any one of the steels permitted by this specification shall be considered as qualification to weld any of the other steels.

(2) A welding operator qualified with an approved electrode-shielding medium combination shall be considered qualified to weld with any other approved electrode-shielding medium combination for the process used in the qualification test.

(3) A welding operator qualified to weld with multiple electrodes or welding heads shall be qualified to weld with a single electrode, but not vice versa. This does not apply for electroslag and electroslag welding.

(4) An electroslag or electrogas welding operator qualified with an approved electrode-shielding medium combination shall be considered qualified to weld with any other approved electrode-shielding medium combination for the process used in the qualification test.

(5) A change in the position in which welding is done shall require qualification in the new position.

7.35 Required Tests

7.35.1 The welding operator qualification test, for other than electroslag or electrogas welding, shall have the following joint detail: 1 in. (25 mm) plate, single V-groove, 20 degree groove angle, 5/8 in. (16 mm) root opening with backing (see Fig. 28). Backing must be at

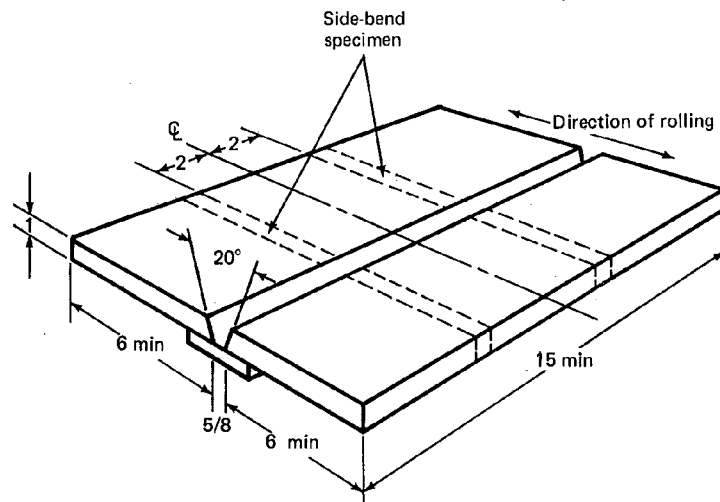

Notes:

1. When radiography is used for testing, no tack welds shall be in test area.
2. The joint configuration of a qualified groove weld procedure may be used in lieu of the groove configuration shown here.

Fig. 28—Test plate for unlimited thickness—welding operator qualification

least $3/8 \times 2$ in. (10 x 51 mm) for mechanical testing, or for radiographic or ultrasonic testing after the backing is removed. Minimum length of the welding groove shall be 15 in. (381 mm). This test will qualify the welding operator for groove and fillet welding in materials of unlimited thickness if the test results are satisfactory.

7.35.2 An electroslag or electrogas welding operator shall be tested by welding a joint in material of the maximum thickness to be used in construction, except that the material thickness for the test weld need not exceed 1-1/2 in. (38 mm) (see Fig. 29). If a 1-1/2 in. (38 mm) thick test weld is made, tests need not be made for thinner sections. This test shall qualify the welding operator for groove welds in material of unlimited thickness if the test results are satisfactory.

7.35.3 The welding operator who makes a complete

joint penetration groove-weld procedure qualification test that meets the test requirements is qualified for that process and test position for plate of the same thickness as the welded test plate. If the test plate is 1-1/2 in. (38 mm) or over in thickness and welded by electroslag or electrogas welding, or 1 in. (25 mm) or over and welded by any other processes, the welding operator will be qualified for all thicknesses with the welding process used if the test results are satisfactory.

A welding operator qualified to weld pipe shall also be qualified to weld plate, but not vice versa, except that qualification on plate in the 1G (flat) or 2G (horizontal) position shall qualify the operator for welding pipe or tubing over 24 in. (610 mm) diameter in the position qualified.

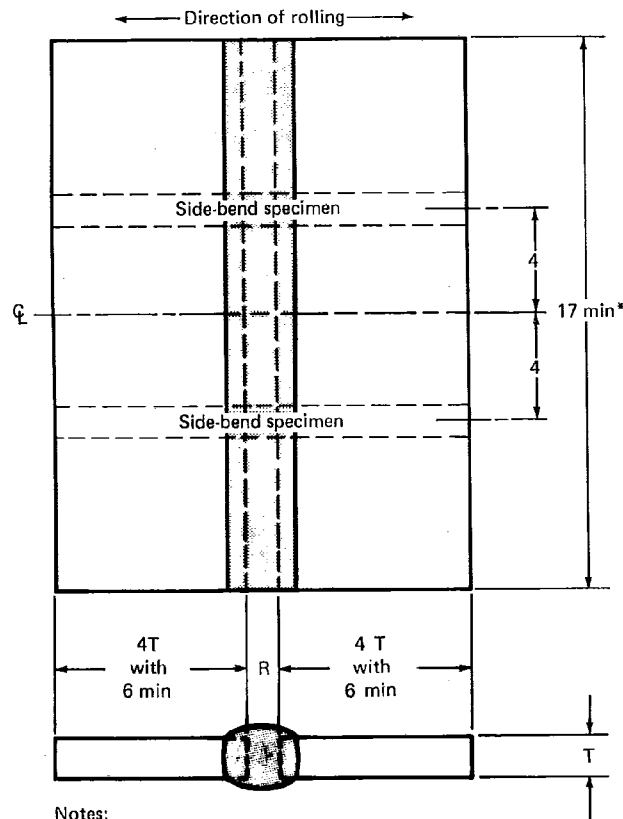

Notes:

1. Root opening "R" established by procedure specification.
2. T = maximum to be welded in construction but need not exceed 1-1/2 in.

*Extensions need not be used if joint is of sufficient length to provide 17 in. of sound weld.

Fig. 29—Butt joint for electroslag and electrogas welding—operator qualification

88/SPECIFICATION FOR WELDING OF INDUSTRIAL & MILL CRANES

7.35.4 For fillet weld qualification only, the welding operator shall weld a test plate according to Option 1 or Option 2, depending on the contractor's choice, as follows:

(1) Option 1 — Weld a T-shaped test plate in accordance with Fig. 30.

(2) Option 2 — Weld a soundness test plate in accordance with Fig. 31.

7.36 Base Metal The base metal used shall comply with Section 2 or the welding procedure specification used for qualification.

7.37 Joint Welding Procedure

7.37.1 The welding operator shall follow the joint welding procedure specified by the welding procedure specification.

7.37.2 Weld cleaning shall be done with the test weld in the same position as the welding position being qualified.

7.38 Test Specimen

7.38.1 Guided-bend test specimens for mechanical testing, shall be prepared by cutting the test plate as shown in Figs. 28, 29, or 31, whichever is applicable, to form specimens approximately rectangular in cross section. The specimens shall be prepared for testing in accordance with Figs. 17A through D, as applicable.

7.38.2 At the manufacturer's option, radiographic testing or ultrasonic testing of the weld may be performed in lieu of the guided-bend test. In that event, the weld reinforcement need not be ground or otherwise smoothed for inspection, unless surface irregularities or juncture with the base metal would cause objectionable weld discontinuities to be obscured during the radiographic or ultrasonic inspection. If the backing is removed for radiographic testing, the root shall be ground flush with the base metal (see 8.7.3).

7.38.3 The fillet-weld-break and macroetch test specimens shall be cut from the test joint as shown in Fig. 30. The exposed section of the macroetch test specimen shall be finished smooth for etching.

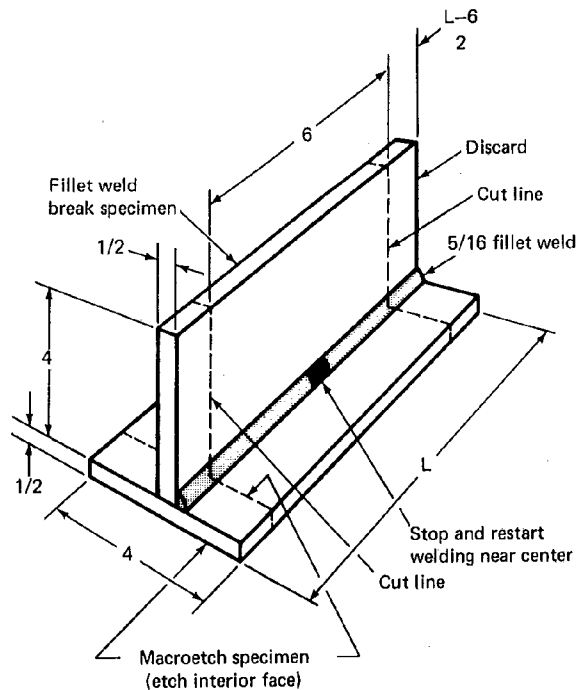

Notes:

1. $L = 15 \text{ min.}$
2. Plate thickness and dimensions are minimum.

Fig. 30—Fillet weld break and macroetch test plate—Option 1—welding operator qualification

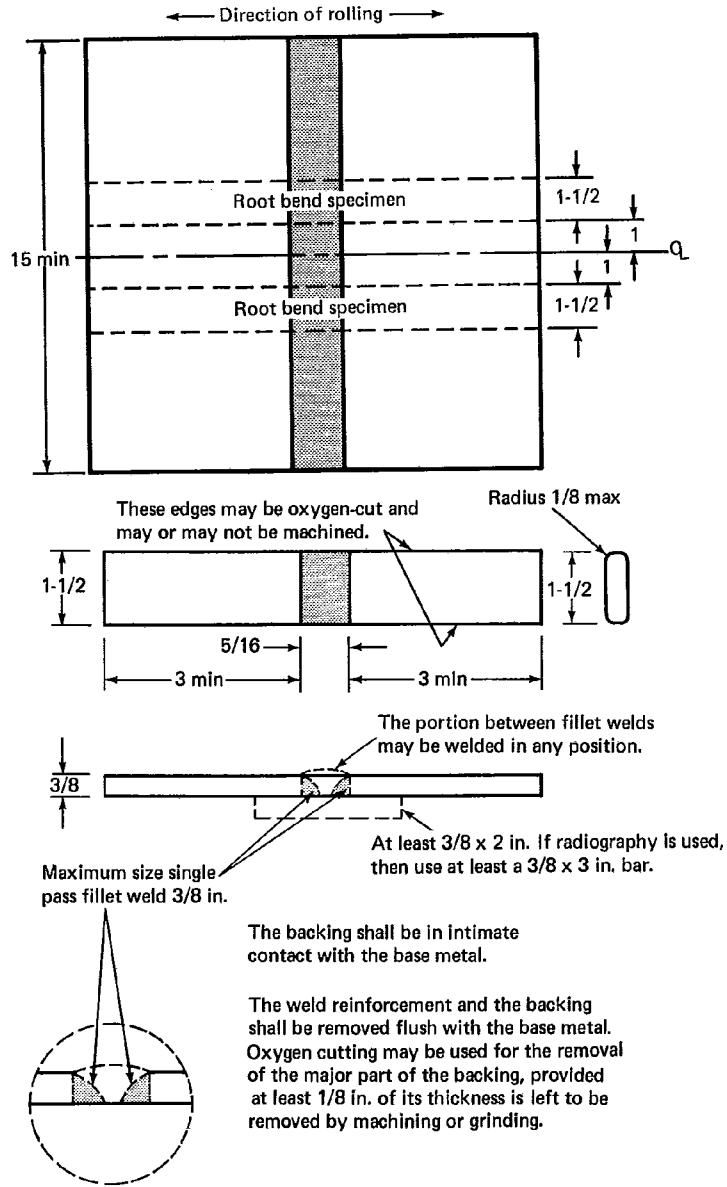

Fig. 31—Fillet weld root-bend test plate—Option 2—welding operator qualification

90/SPECIFICATION FOR WELDING OF INDUSTRIAL & MILL CRANES

7.39 Method of Testing Specimens

7.39.1 Root- or Side-Bend Specimens. Each specimen shall be bent in a jig as shown in Fig. 26A having the appropriate dimensions for the base metal strength. Any convenient means may be used to move the plunger member with relation to the die member. The specimen shall be placed on the die member of the jig with the weld at midspan. Side-bend specimens shall be placed with the side having the larger discontinuities, if any, directed toward the die member.

7.39.2 Radiographic procedure and technique shall be in accordance with the requirements of Section 8. Only the center 50 percent of the test weld length shall be subject to testing.

7.39.3 The ultrasonic procedure and technique shall be in accordance with the requirements of Section 8.

7.39.4 Fillet Weld Break Test. The entire length of the fillet weld shall be examined visually. Then a 6 in. (152 mm) long specimen shall be cut from the test sample and loaded in such a way that the root of the weld is in tension. The load shall be steadily increased or repeated until the specimen fractures or bends flat upon itself.

7.39.5 Macroetch Test. The test specimens shall be prepared with a finish suitable for macroetch examination. A suitable solution shall be used to give a clear definition of the weld area.

7.40 Test Results Required

7.40.1 Root-, Side-Bend Test. The convex surface of the specimen shall be examined for the appearance of cracks or other open discontinuities. Any bent specimen containing a crack or other open discontinuity exceeding 1/8 in. (3 mm), measured in any direction, shall be considered as failed. Cracks occurring on the corners of the specimen during testing shall not be considered.

7.40.2 Welds tested by radiographic or ultrasonic examination shall conform to the requirements of Section 8.

7.40.3 Fillet Weld Break Test

7.40.3.1 To pass the visual examination, the fillet weld must present a reasonably uniform appearance and must be free of overlap, crack, and excessive undercut. There must be no porosity visible on the face of the weld.

7.40.3.2 The specimen passes the test if it bends flat upon itself. If the fillet weld fractures, the fractured surface must show complete fusion to the root of the joint and must exhibit no inclusion or porosity larger than 3/32 in. (2.4 mm) in the greatest dimension. The sum of the greatest dimensions of all inclusions and porosity must not exceed 3/8 in. (9.5 mm) in the 6 in. (152 mm) long specimen.

7.40.4 Macroetch Test. The test specimen shall be

examined for discontinuities. If any discontinuities prohibited by 8.6 are found on the surface, the specimen shall be considered to have failed. The weld must show complete fusion to the root, but not necessarily beyond, and both legs must be equal within 1/8 in. (3 mm). Convexity must not exceed the limits specified in 8.7.

7.40.5 Visual Inspection. For acceptable qualification, the welded test plate, when inspected visually, shall conform to the requirements for visual inspection in Section 8.

7.41 Retests. If one or more test welds made by a welding operator fails to meet the requirements, a retest may be allowed under the following conditions:

(1) An immediate retest may be made consisting of two test welds of each type on which the welding operator failed. The retest specimens shall meet all the requirements specified for such welds.

(2) A retest may be made, provided there is evidence that the welding operator has had further training or practice. In this case, one complete retest shall be made.

7.42 Period of Effectiveness. The welding operator's qualification specified in this section shall remain in effect indefinitely unless (1) the welding operator is not engaged in a given process of welding for which he is qualified for a period exceeding 6 months or (2) there is some specific reason to question the welding operator's ability.

7.43 Records. Records of the test results shall be kept by the manufacturer or contractor, and shall be available to those authorized to examine them (see suggested sample form in Appendix A).

Part E**Qualification of Tack Welders**

7.44 General. The Qualification tests described in this section are specifically devised to determine a tack welder's ability to produce sound tack welds. The qualification tests are not intended to be used as a guide for tack welding during actual construction. The latter shall be performed in accordance with the requirements of the welding procedure specification. For an alternate method of qualification, see 7.32.

7.45 Limitations. For the qualification of a tack welder, the following rules apply:

(1) Qualification established with any one of the steels permitted by this specification shall qualify the tack welder to tack weld any of the other steels.

(2) Qualification of a tack welder for shielded metal arc welding with an electrode identified in Table 14 shall

qualify the tack welder to tack weld with any other electrode in the same group designation, and with any electrode listed in a numerically lower group designation.

(3) Qualification of a tack welder with an approved electrode-shielding medium combination shall qualify the tack welder to tack weld with any other approved electrode-shielding medium combination for the process used in the qualification test.

(4) A tack welder shall be qualified for each process used.

(5) A change in the position in which tack welding is done, as defined in 7.8, shall require qualification in the new position.

7.46 Qualification Tests Required. A tack welder shall be qualified by making one test specimen in each position in which he will tack weld on the job.

7.47 Base Metal. The base metal used shall comply with the procedure specification.

7.48 Test Specimen. The tack welder shall make a tack weld of 1/4 in. (6 mm) maximum size and approximately 2 in. (51 mm) long on a fillet-weld-break specimen, shown in Fig. 32, using a 5/32 in. (4 mm) diameter electrode.

7.49 Method of Testing. A force shall be applied to the specimen, as shown in Fig. 33, until rupture occurs. The force may be applied by any convenient means. The surface of the weld prior to testing and the fracture surface shall be examined visually for discontinuities.

7.50 Test Results Required

7.50.1 A qualification tack weld must have a reasonably uniform appearance and be free of overlap, cracks, and excessive undercut. There must be no visible porosity on the surface of the tack weld.

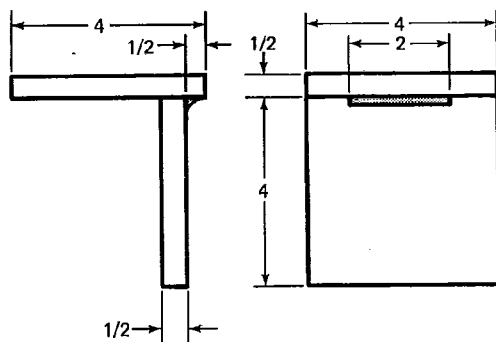

Fig. 32—Fillet weld break specimen—tack welder qualification

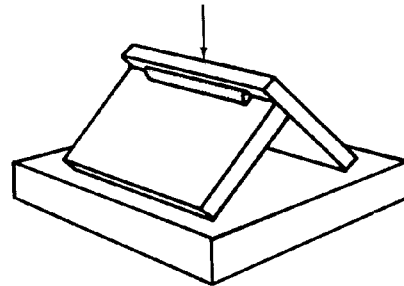

Fig. 33—Method of fracturing specimen—tack welder qualification

7.50.2 The fractured surface of the tack weld must show complete fusion to the root, but not necessarily beyond, and complete fusion to the base metal. Any inclusion or porosity larger than 3/32 in. (2.4 mm) in greatest dimension is unacceptable.

7.50.3 A tack welder who passes the fillet weld break test shall be eligible to tack weld all types of joints in the position and with the welding process used for qualification.

7.51 Retests. In case of failure to pass the qualification test, the tack welder may make one retest without additional training.

7.52 Period of Effectiveness. A tack welder who passes the qualification test shall be eligible to perform tack welding indefinitely in the positions and with the processes used for qualification unless there is some specific reason to question the tack welder's ability. In such cases, the tack welder shall be required to demonstrate the ability to make sound tack welds by again passing the prescribed welding test.

7.53 Records. Records of the test results shall be kept by the manufacturer or contractor, and shall be available to those authorized to examine them (see suggested sample form in Appendix A).

8. Weld Quality and Inspection

8.1 General

8.1.1 Inspection personnel shall perform tests as necessary prior to, during, and after assembly and welding to insure that materials and workmanship meet the requirements of this specification.

8.1.2 Inspection personnel utilized in performing welding inspection, other than visual, shall be thoroughly

92/SPECIFICATION FOR WELDING OF INDUSTRIAL & MILL CRANES

trained and certified according to some recognized standard. This minimum requirement applies both to the inspection personnel employed by the manufacturer and to the purchaser's representative.

8.1.3 When certified welding inspectors are required, it shall be so stated in information furnished to the bidders and specified in the contract documents. When so specified, inspectors shall be qualified in accordance with the provisions of AWS-QC-1, *Standard for Qualification and Certification of Welding Inspectors*.

8.2 Purchaser's Representative

8.2.1 A representative designated by the purchaser, when required by the contract, shall verify that all fabrication by welding is performed in accordance with the requirements of this specification. At their discretion, owners, or their representatives, may waive verification of welding and fabrication inspection.

8.2.2 The representative shall be furnished with or have access to a complete set of detailed drawings showing the size, length, type, and location of all welds that are to be made.

8.2.3 The representative shall be notified in advance of the start of any welding operations, when required by the contract.

8.2.4 The representative shall not delay the normal operating schedule of the manufacturer if the representative cannot be on-site after proper notification, unless otherwise agreed in the contract.

8.2.5 The representative shall have the option of performing all, or any part of, the functions set forth in 8.3, 8.4, 8.5.

8.2.6 If agreed to in the contract, the representative may keep records of all welder and welding operator qualifications, all procedure qualifications, other tests that are made, and other information that may be required for the execution of duties. Otherwise, this information shall be made available for review at the manufacturer's facility.

8.3 Inspection of Welding Procedure Qualifications.

The purchaser's representative may witness or review the records of welding and testing of any procedure qualification that are required in this specification.

8.4 Inspection of Welder, Tack Welder, and Welding Operator Qualification.

The purchaser's representative shall only permit welding to be performed by welders, tack welders, and welding operators who are qualified in advance in accordance with the requirements of this specification. If retesting or qualification is required, the purchasing representative may witness the welding and testing of the qualification test for each welder, tack welder, or welding operator. Otherwise, the purchasing

representative may review the records of past qualification and testing.

8.5 Inspection of Work and Records

8.5.1 The purchaser's representative shall make certain that the size, length, and location of welds conform to the requirements of this specification and to the detailed drawings, and that no specified welds are omitted.

8.5.2 The purchaser's representative shall make certain that only those welding procedures that meet the provision of this specification are employed.

8.5.3 The purchaser's representative may, at suitable intervals, observe the technique and performance of any welder, welding operator, or tacker to make certain that the applicable workmanship requirements of Section 5 are being met.

8.5.4 The purchaser's representative may examine the work to make certain that it meets the requirements of the workmanship standards of this specification. Size and contour of the welds shall be measured with suitable gauges. Visual inspection for cracks in welds and base metal and for other defects should be aided by strong light or other devices, such as magnifiers, where they may be helpful.

8.5.5 The purchaser's representative should identify all parts or joints that have been inspected and accepted with a distinguishing mark.

8.6 Visual Examination. All welds shall be visually examined. A weld shall be acceptable by visual examination if it makes the specified size on the drawings (see Section 5 — Workmanship), and the following conditions are met:

- (1) The weld has no cracks.
- (2) Complete fusion exists between adjacent layers of weld metal and between weld metal and base metal.
- (3) All craters are filled to the full cross section of the weld.
- (4) Weld profiles are in accordance with 8.7.
- (5) Permissible frequency and size of piping porosity in fillet welds shall be limited as follows:
 - (a) For primary welds, no more than 1 pore in each 4 in. (102 mm) of length, and no larger in diameter than 3/32 in. (2.4 mm).
 - (b) for secondary welds, the sum of the diameters of piping porosity shall not exceed 3/8 in. (9.5 mm) in any linear inch of weld, and shall not exceed 3/4 in. (19 mm) in any 12 in. (305 mm) length of weld.
- (6) The actual size of a portion of continuous fillet weld, 3/8 in. (9.5 mm) or larger, can be under the nominal required fillet weld size by 1/16 in. (1.6 mm) without correction, provided that the undersize portion does not exceed 10 percent of the weld length. On web-to-flange

fillet welds on girders, no undersize weld is permitted at the end of the joint in a length equal to twice the width of the flange.

(7) Primary groove welds must have no piping porosity. Secondary groove welds shall meet the porosity requirements for fillet welds in 8.6(5)(a).

(8) Visual examination of completed welds in all steels except those considered air-hardenable, such as, ASTM A514 and A517, can be done immediately after the welds are cooled to ambient temperature. Visual examination of completed welds in air-hardenable steels shall not be performed until 48 hours after completion.

8.7 Welding Profiles

8.7.1 The faces of fillet welds may be slightly convex, flat, or slightly concave, as shown in Figs. 34(A), (B), and (C), but with none of the unacceptable profiles shown in (D). Except at outside corner joints, the concavity, C, must not exceed the sum of $0.1S + 0.03$ in. (1 mm), where S is the actual size of the fillet weld in inches (mm). See Fig. 34(B).

8.7.2 Groove welds shall preferably be made with slight or minimum reinforcement, except as may be otherwise provided. In case of butt and corner joints, the reinforcement height, R, must not exceed 1/8 in. (3 mm) for metal thickness of 2 in. (51 mm) and under, and 3/16 in. (5 mm) for metal thicknesses over 2 in. (51 mm). It must have gradual transition to the plane of the base metal surface, as shown in Fig. 34(E). Groove welds must be free of the discontinuities shown for butt joints in Fig. 34(F).

8.7.3 Where the surface of butt joints are required to be flush, the thickness of the thinner base metal or weld metal shall not be reduced by more than 1/32 in. (0.8 mm), or 7 percent of the thickness, whichever is smaller, and weld reinforcement shall not exceed 1/32 in. (0.8 mm). However, all reinforcement must be removed where the weld forms part of a faying or contact surface. Any reinforcement must blend smoothly into the plate surfaces with transition areas free from undercut. Chipping may be used, provided it is followed by grinding. Where surface finishing is required, the roughness¹⁸ value shall not exceed 250×10^{-6} in. (6×10^{-6} m). Surfaces finished to values of over 125×10^{-6} in. (3×10^{-6} m) through 250×10^{-6} in. shall be finished parallel to direction of primary stress. Surface finished to 125×10^{-6} in. or less may be finished in any direction.

8.7.4 Undercut depth shall not exceed 1/32 in. (0.8 mm) or 7 percent of the base metal thickness, except that Category IV, V, and VI welds with a total undercut of less than 1/2 in. (13 mm) in length in any linear 12 in. (305

mm) of weld are acceptable without measurement of the undercut depth.

8.7.5 Welds shall be free from overlap.

8.7.6 Fillet welds may not deviate from designated size by more than the tolerances shown in Fig. 34 and Section 8.6(6). If the deviation exceeds these figures, the weld must be corrected as noted in Section 10.

8.8 Nondestructive Examination

8.8.1 Nondestructive testing (other than visual inspection) of weld joints other than Category I or II, when it is to be required as a part of the contract, shall be announced in the information furnished to bidders. The information provided should designate the inspection process to be employed, the welds to be examined, and the extent of examination of each weld. Such nondestructive examination shall be conducted in accordance with the requirements of this specification, or as modified by mutual agreement between the manufacturer and purchaser.

8.8.2 Welds that do not meet the nondestructive examination requirements of this specification shall be repaired by the methods permitted by Section 10.

8.8.3 Nondestructive examination in this specification is only intended to apply to primary welds, unless otherwise specifically agreed to in the contract between the manufacturer and the purchaser.

8.8.4 A weld that is to be subjected to nondestructive examination need not be ground or otherwise smoothed, provided surface irregularities or juncture with the base metal do not obscure objectionable weld discontinuities during examination.

8.9 Radiographic Examination of Welds

8.9.1 The procedures and standards set forth in this section are to govern radiographic testing of welds when such inspection is required by stipulation of 8.8. These procedures are restricted to inspection of groove welds with complete joint penetration.

8.9.2 Variations in testing procedure, equipment, and acceptance standards from those given in this section may be used upon agreement with the purchaser. Such variations include the radiographic inspection of fillet welds, T-welds, or corner welds; changes in source-to-film distance; unusual geometries; unusual penetrometer application, film type or densities; and film exposure or development variations.

8.9.3 Information furnished to the bidders shall clearly identify the extent of radiographic inspection.

8.9.4 Complete inspection, when specified, requires that the entire length of weld in each designated joint shall be inspected.

8.9.5 Spot inspection, when specified, requires that the

18. Refer to American National Standard B46.1-78, *Surface Texture*, American National Standards Institute.

94/SPECIFICATION FOR WELDING OF INDUSTRIAL & MILL CRANES

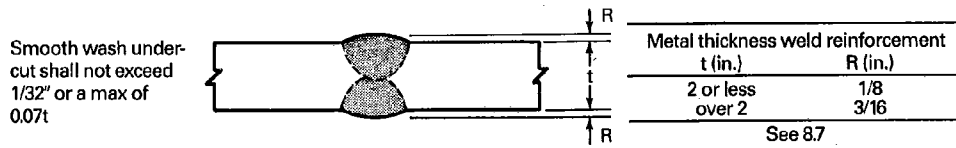
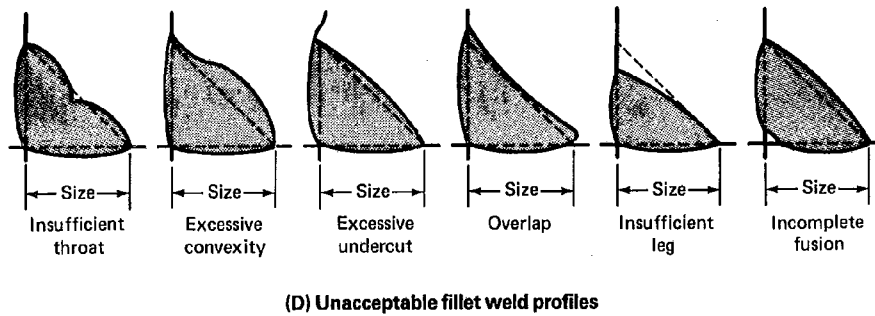
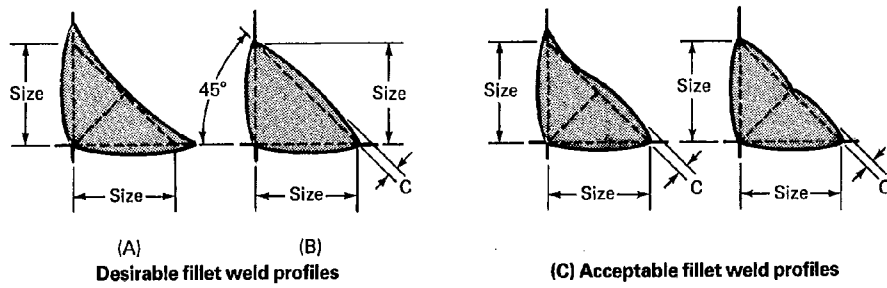

(E) Acceptable butt joint weld profile

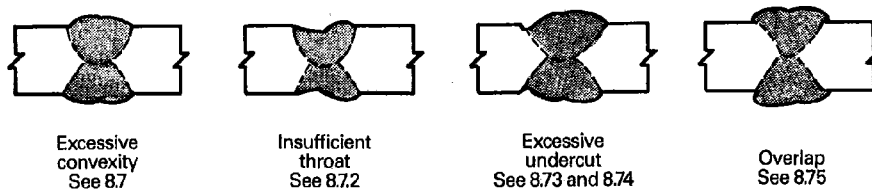

Weld Size Tolerances	
Weld Size in. (mm)	Weld Size Tolerance in. (mm)
Under 3/8" (10)	-0 + 1/16 (+ 1.5)
3/8" (10) or larger	- 1/16 + 1/8 (+ 3)

Fig. 34—Acceptable and unacceptable weld profiles

number of spots to be radiographed in a stated length of weld in each designated category of weld joint shall be included in information furnished to bidders. Each spot radiograph shall show at least 4 in. (102 mm) of weld length. If a spot radiograph shows discontinuities that require repair, as defined in 8.11, two adjacent spots shall be inspected. If discontinuities requiring repair are detected in either of these, the entire length of weld in that joint shall be inspected radiographically.

8.10 Radiographic Procedure

8.10.1 Radiographs shall be made by either x-ray or isotope radiation methods. Radiography shall be conducted in accordance with ASTM E94, *Standard Recommended Practice for Radiographic Testing*, and ASTM E142, *Standard Method for Controlling Quality of Radiographic Testing*, latest revisions.

8.10.2 The quality level of inspection for radiographs shall be 2-2T, except that the diameter of the 2T penetrometer hole need not be less than 1/16 in. (1.6 mm) for x-ray or 3/32 in. (2.4 mm) for gamma ray radiographs.

8.10.3 Radiographs shall have a H & D density¹⁹ between 1.5 and 3.5.

8.10.4 Two or more penetrameters shall be used for each radiograph on a film 10 in. (254 mm) or more in length. Only one penetrometer need be used for radiographs on films less than 10 in. (254 mm) in length.

8.10.5 Radiographs shall be made with a single source of radiation approximately centered with respect to the length and width of the area being examined. The distance from radiation source to the film shall not be less than 7 times the maximum thickness of the weld being examined, and the rays shall not penetrate the weld at an angle greater than 26-1/2 degrees from a line perpendicular to the weld surface. The film, during exposure, shall be as close as possible to the surface of the weld opposite the source of radiation.

8.11 Acceptability of Radiographed Welds

8.11.1 Welds subject to radiographic examination shall first be visually examined in accordance with the requirements of 8.6 and 8.7.

8.11.2 The greatest dimension of any porosity or fusion-type discontinuity indications that are 1/16 in. (1.6 mm) or larger shall not exceed size, B, indicated in Fig. 35 for the effective throat of a groove weld or weld size of a fillet weld. The distance from any indication of porosity or fusion-type discontinuity to another such indication, to an edge, or to any intersecting weld shall not be less

than the minimum clearance allowed, C, indicated in Fig. 35 for the size of discontinuity under examination. Appendix C illustrates the application of the requirements given in 8.11.2.

8.11.3 Discontinuities meeting requirements of 8.11.1 and having a greatest dimension of less than 1/16 in. (1.6 mm) are nevertheless not acceptable if the sum of their greatest dimensions 3/8 in. (9.5 mm) in any linear inch (25 mm) of weld.

8.11.4 The limitations for 1-1/2 in. (38 mm) groove weld effective throat given in Fig. 35 shall apply to all welds with larger effective throats.

8.11.5 A recommended form for reporting the results of radiographic examination is shown in Appendix A.

8.12 Examination, Report, and Disposition of Radiographs

8.12.1 The contractor shall provide a suitable high intensity viewer with sufficient capacity to illuminate radiographs with a density of 4.0 without difficulty. It is recommended that at least a two-level or variable intensity illuminator be used.

8.12.2 All radiographs of welds that are subject to contractual radiographic examination by the manufacturer, including those that show unacceptable quality prior to repair, and a report interpreting them, shall be available for review by the purchaser's representative before the weld is accepted.

8.12.3 A full set of radiographs for welds subject to radiographic testing by the manufacturer for the purchaser, including those that show unacceptable quality prior to repair, shall be delivered to the purchaser upon completion of the work. The manufacturer's obligation to retain radiographs shall cease (1) upon delivery of this full set to the owner, (2) one full year after completion of the manufacturer's work, in the event that delivery is not required, or (3) as otherwise stated in the contract.

8.13 Ultrasonic Examination of Welds

8.13.1 The procedures and standards set forth in this section govern the ultrasonic testing of groove welds between the thicknesses of 5/16 in. (8 mm) and 8 in. (203 mm) inclusive, when such testing is required by 8.8 of this specification. These procedures and standards are not to be used as a basis for rejection of the base metal.

8.13.2 Variations in testing procedure, equipment, and acceptance standards not included in this section may be used by agreement between the manufacturer and purchaser. Such variations include other thicknesses, weld geometries, transducer sizes, frequencies, and couplants.

8.13.3 Spot radiography is suggested to supplement ultrasonic testing of electroslog and electrogas groove

19. H & D density, D, is a measure of film blackening expressed as $D = \log(I_0/I)$, where:
 I_0 = light intensity on the film
 I = light transmitted through the film

96/SPECIFICATION FOR WELDING OF INDUSTRIAL & MILL CRANES

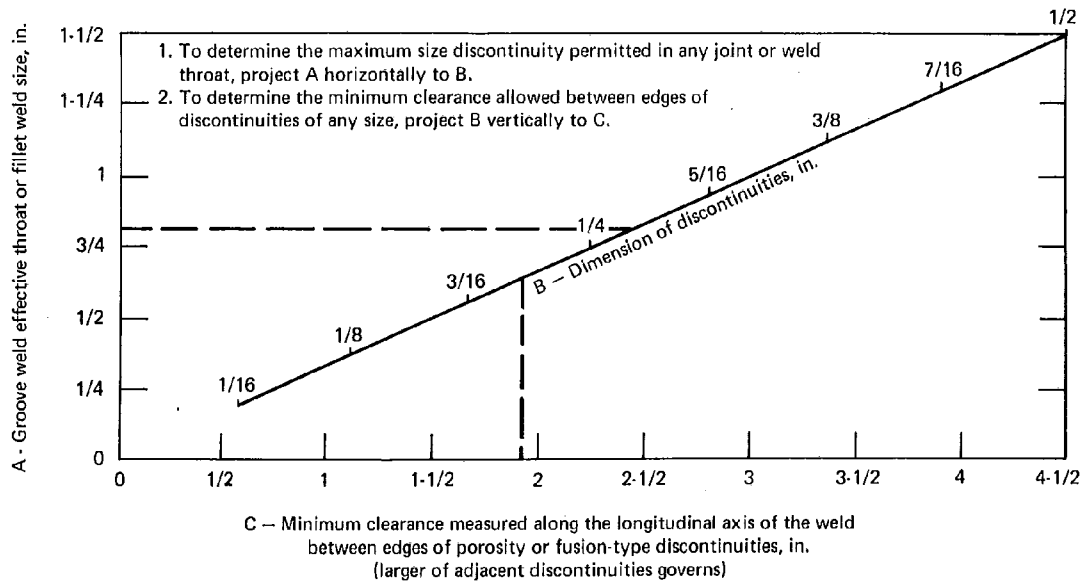

Note: Adjacent discontinuities, spaced less than the minimum required clearance shall be measured as one length equal to the sum of the total length of the discontinuities plus the length of the space between them and evaluated as a single discontinuity.

Fig. 35—Weld quality requirements for discontinuities occurring in tension welds (limitation of porosity and fusion type discontinuities)

welds in material 2 in. (51 mm) and over in thickness to detect possible piping porosity.

8.13.4 Information furnished to bidders shall clearly identify the extent of ultrasonic testing required.

8.13.5 Complete testing when specified, requires testing of the entire length of the weld in each designated joint.

8.13.6 Spot testing when specified, requires that the number of spots in each designated category of weld, or the number required to be made in a stated length of weld, be included in the information furnished to bidders. Each spot testing reveals discontinuities that require repair, two adjacent spots shall be tested. If discontinuities requiring repair are revealed in either of these, the entire length of the weld in that joint shall be tested ultrasonically.

8.14 Ultrasonic Testing Equipment and Calibration

8.14.1 The apparatus for ultrasonic examination shall meet the requirements of ASTM E164, *Recommended Practice for Ultrasonic Contact Examination of Weldments*, and ASTM E317, *Recommended Practices for Evaluating Performance Characteristics of Pulse-Echo Ultrasonic Testing Systems*. Refer to ASTM E500, *Definitions of Terms Relating to Ultrasonic Testing* (latest revision) for standard definitions of terms.

8.14.2 Test instruments shall include internal stabilization so that after warm up, no variation in response greater than ± 1 dB occurs with supply voltage changes of 15 percent nominal or, in the case of battery powered instruments, over the battery charge operating life. There shall be an alarm or meter to signal a drop in battery voltage prior to instrument shutoff due to battery exhaustion.

8.14.3 The test instrument shall have a calibrated gain control (attenuator) adjustable in discrete 1 or 2 dB steps over a range of at least 60 dB.

8.14.4 The dynamic range of the instrument's CRT display shall be such that a difference of 1 dB of amplitude can be easily detected on the CRT.

8.14.5 Each search unit shall be marked to clearly indicate the frequency of the transducer, nominal angle of refraction, and index point.

8.14.6 Preferred couplants are a cellulose gum-water mixture, and glycerine with a wetting agent. Where possible, avoid the use of oil or grease as the couplant for examination of welds. If oil and grease are used as couplants, the requirements of 5.2.1 must be met before any repairs are made.

8.14.7 The horizontal linearity of the test instrument shall be within plus-or-minus 5 percent over the linear

range that includes 90 percent of the sweep length presented on the CRT screen for the longest sound path to be used. The horizontal linearity shall be measured by the techniques prescribed in Section 7.9 of ASTM A317, except that the results may be tabulated rather than graphically represented. Horizontal linearity shall be checked after each 40 hours of instrument use.

8.14.8 Internal reflections from the search unit, with a screen presentation higher than the horizontal reference line, appearing on the screen to the right of the sound entry point shall not occur beyond 1/2 in. (13 mm) equivalent distance in steel when the sensitivity is set as follows: 20 dB more than that required to produce a maximized horizontal reference line height indication from the 0.06 in. (1.5 mm) diameter hole in the International Institute of Welding (IIW) reference block (see ASTM E164).

8.14.9 The dimensions of search unit shall be such that the minimum allowable distance, X, between the toe of the search unit and the edge of the IIW block, shall be as follows:

- (1) 70 degree transducer, X = 2 in. (51 mm)

- (2) 60 degree transducer, X = 1-5/8 in. (41 mm)

- (3) 45 degree transducer, X = 1 in. (25 mm)

The search unit shall be positioned for maximum indication from 0.6 in. (1.5 mm) diameter hole in the IIW calibration block.

8.14.10 Resolution

8.14.10.1 For shear waves, the combination of search unit and instrument shall resolve the appropriate 3 hole in the resolution test block shown in Fig. 36A. For 70 degree angle, set the transducer in position Q on the resolution block. The resolution shall be evaluated with the instrument controls set at normal test settings, and with indications from the holes brought to midscreen height. Resolution shall be sufficient to distinguish at least the peaks of indications from the 3 holes.

8.14.10.2 To determine longitudinal wave resolution, the instrument controls must be at normal settings with indications from the holes brought to midscreen height (see Fig. 36B).

- (1) Set the transducer in position F on the IIW block.

- (2) Transducer and instrument should resolve all 3 distances.

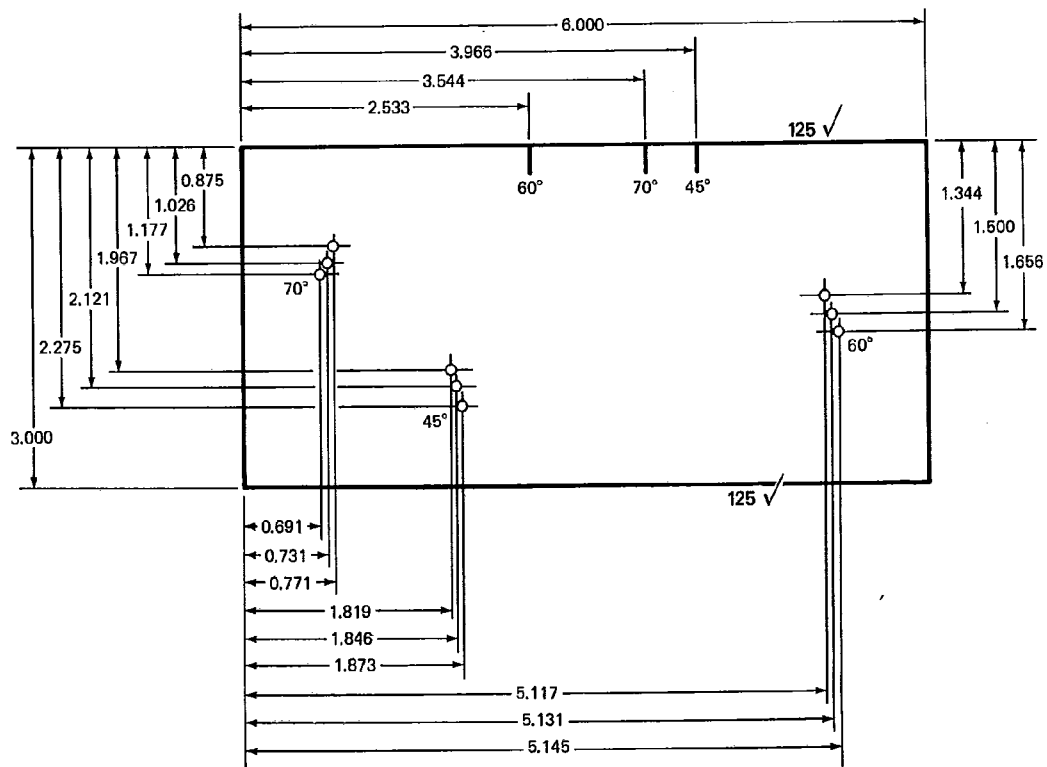

The test block is 3 in. x 1 in. x 6 in. Finish all over to a maximum of 125 μ m rms

Fig. 36A-RC-Resolution reference block

98/SPECIFICATION FOR WELDING OF INDUSTRIAL & MILL CRANES

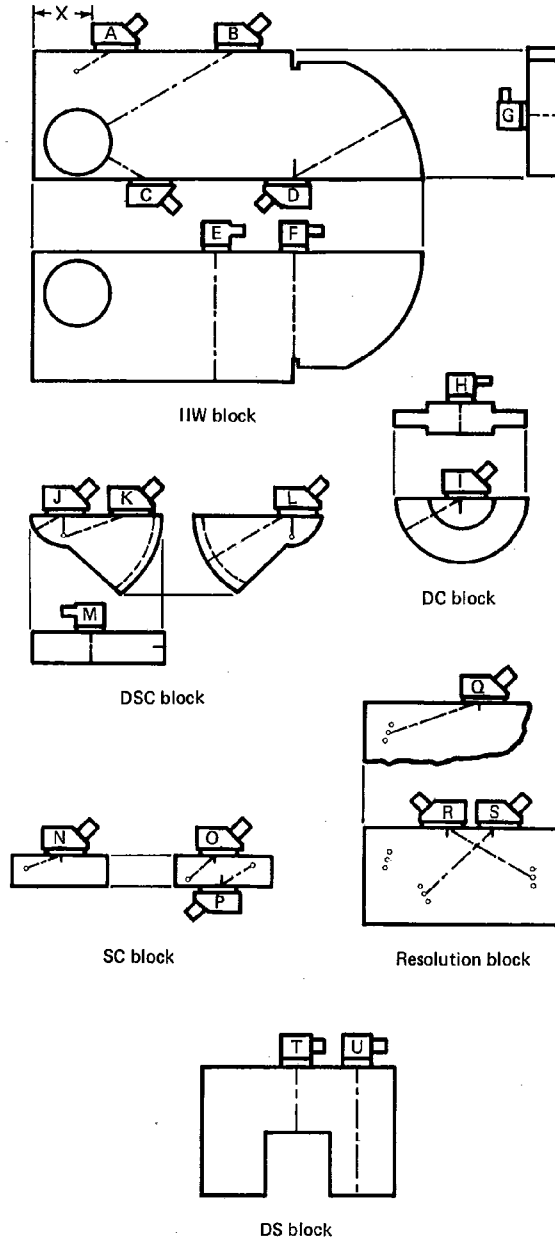

Fig. 36B—Transducers positions (typical)

8.14.11 The IIW ultrasonic reference block, shown in ASTM E164, shall be the standard used for both distance and sensitivity calibration. More portable reference blocks of other designs may be used, provided they meet the requirements of this specification and are referenced back to the IIW block. Approved designs are shown in ASTM E64. See Fig. 36B for application.

8.14.12 Using a corner reflector for calibration purposes is prohibited.

8.14.13 The gain control (attenuator) of the instrument shall meet the requirements of 8.14.3, and shall be checked for correct calibration at 2 month intervals in accordance with a procedure approved by the manufacturer of the instrument.

8.14.14 With the use of an approved calibration block, each angle beam search unit shall be checked after each 8 hours of use to determine that (1) the contact face is flat, (2) the sound entry point is correct, and (3) the beam angle is within the permitted plus-or-minus 2 degree tolerance. Search units that do not meet these requirements shall be corrected or replaced.

8.14.15 Calibration for sensitivity and horizontal sweep (distance) shall be made at the location of testing by the ultrasonic operator just prior to examination of each weld and at intervals of 30 minutes during examination. Recalibration shall be made when (1) there is a change of operators, (2) transducers are changed, (3) new batteries are installed, and (4) equipment operating from a 110 volt source is connected to a different power outlet.

8.14.16 Calibration for straight beam testing shall be performed as follows:

(1) The horizontal sweep shall be adjusted for distance calibration to present the equivalent of at least 2 plate thicknesses on the CRT screen.

(a) Set the transducer in position G on the IIW block, position H on the DC block, or position M on the DSC block (see Fig. 36B).

(b) Adjust instrument to produce indications at 1 in. (25 mm), 2 in. (51 mm), 3 in. (76 mm), 4 in. (102 mm), etc., on the CRT.

(2) The sensitivity (gain) shall be adjusted at a location free of indications so that the first back reflection from the far side of the plate will be 50 to 70 percent of full screen height. For this purpose, the reject (clipping) control shall be turned off.

8.14.17 Calibration for angle beam testing shall be performed as follows:

(1) The horizontal sweep shall be adjusted to represent the actual sound path distance by using acceptable distance calibration blocks shown in Figs. 36A and ASTM E164. This distance calibration shall be made using either the 5 in. (127 mm) scale or the 10 in. (254 mm) scale on the CRT screen, whichever is appropriate, unless joint

configuration or thickness prevents full examination of the weld at either of these settings.

(a) Set the transducer in position D on the IIW block (any angle).

(b) Adjust the instrument to attain indications on the cathode ray tube (CRT) at 4 in. (102 mm) and 8 in. (203 mm), 9 in. (229 mm) on Type 1 block, or 8 in. (203 mm) on Type 2 block.

(c) Set the transducer in position J or L on the DSC block (any angle).

(d) Adjust the instrument to attain indications on the CRT at 1 in. (25 mm), 5 in. (127 mm), 9 in. (229 mm) in the J position, or at 3 in. (76 mm), and 7 in. (178 mm) in the L position.

(e) Set the transducer in position I on the DC block (any angle).

(f) Adjust the instrument to attain indications on the CRT at 1 in. (25 mm), 2 in. (51 mm), 3 in. (76 mm), 4 in. (102 mm), and so forth.

(2) With the unit adjusted to conform with the requirements of 8.14.1 through 8.14.10, the sensitivity shall be adjusted by the use of the gain control (attenuator) so that a horizontal reference level trace deflection results on the CRT screen with the maximum indication from the 0.06 in. (1.5 mm) diameter hole in the IIW block, or from the equivalent reference reflector in other acceptable calibration blocks. This basic sensitivity then becomes the zero reference level for discontinuity evaluation and shall be recorded on the ultrasonic test reports under reference level. See Appendix A for a sample ultrasonic test report form.

(a) Set the transducer in position A on the IIW block (any angle).

(b) Adjust the maximized signal from the 0.06 in. (15 mm) hole to attain a horizontal reference line height indication.

(c) Set the transducer in position L on the DSC block (any angle).

(d) Adjust the maximized signal from the 1/32 in. (0.8 mm) slot to attain a horizontal reference line height indication.

(e) Set the transducer on the SC block in position N for 70 degree angle, position O for 45 degree angle, or position P for 60 degree angle.

(f) Adjust the maximized signal from the 1/16 in. (1.6 mm) hole to attain a horizontal reference line height indication.

(g) The decibel reading obtained in (f) shall be used as the reference level, b, reading on the test report sheet (see Appendix A).

100/SPECIFICATION FOR WELDING OF INDUSTRIAL & MILL CRANES

8.15 Ultrasonic Testing Procedure, Acceptance Criteria and Reports

8.15.1 The letter Y accompanied by a weld identification number shall be clearly marked on the base metal adjacent to the weld at the left end of each weld that is ultrasonically tested. This identification number serves as an orientation direction for weld discontinuity location and as the report number on the report form (see Appendix A for suggested report form).

8.15.2 All surfaces to which a search unit is applied shall be free of weld spatter, dirt, grease, oil, (other than that used as a couplant) and loose scale, and shall have a contour permitting intimate coupling. Tight layers of paint need not be removed unless their combined thickness exceeds 0.010 in. (0.25 mm).

8.15.3 A couplant shall be used between the search unit and the metal. The couplant shall be either glycerine with a wetting agent, if needed, or a cellulose gum and water mixture of a suitable consistency. Light machine oil, or equivalent, may be used for couplant on calibration blocks.

8.15.4 The entire base metal through which ultrasonic vibrations must travel to test the weld shall be tested for laminar reflectors, using a straight beam search unit conforming to the requirements of 8.14. If any area of base metal exhibits total loss of back reflection and is located in a position that would interfere with the normal weld scanning procedure, the following alternate weld scanning procedure shall be used. Alternate weld procedure inspection may also be conducted in accordance with ASTM E164.

(1) The area of the laminar reflector and its depth from the surface shall be determined and reported on the ultrasonic test report.

(2) If part of a weld is inaccessible to testing in accordance with the requirements of Table 17 because of laminar content recorded in accordance with 8.15.4(1), the testing shall be conducted by using an alternate scanning pattern described in 8.15.5, by first grinding the weld surfaces flush to make total weld areas accessible to ultrasonic testing, or both.

8.15.5 Alternate Scanning Patterns (See Fig. 37)

(1) Longitudinal Discontinuities. Scanning patterns shall consist of the following combined movements:

(a) Scanning movement A — Rotation angle, a , equals 10 degrees.

(b) Scanning movement B — Scanning distance, b , shall be sufficient to ensure that the section of weld being tested is covered.

(c) Scanning movement C — Progression distance, c , shall be approximately one-half of the transducer width.

(2) Transverse Discontinuities

(a) Scanning pattern D — when welds are ground flush.

(b) Scanning pattern E — when weld is not ground flush.

(c) Scanning angle $e = 15$ degree maximum.

(d) Scanning pattern shall ensure the full weld section is covered.

(3) Electroslag or Electro gas Welds. (additional scanning pattern) — scanning pattern E

(a) Search unit rotation angle, e , between 45 and 60 degrees.

(b) Scanning pattern shall ensure that the full weld section is covered.

8.15.6 Welds shall be tested using an angle beam search unit conforming to the requirements of 8.14. Following calibration and during testing, the only instrument adjustment permitted is in the sensitivity level adjustment with the calibrated gain control or attenuator. Sensitivity shall be increased from the reference level for weld scanning in accordance with Table 18.

8.15.6.1 If mechanically possible, all welds shall be scanned from both sides on the same face for longitudinal and transverse discontinuities. The applicable scanning pattern, or patterns, shown in Fig. 37 shall be used.

8.15.6.2 The testing angle shall be as shown in Table 18, and the transducer must conform to ASTM E164 and paragraph 8.14 of this specification.

8.15.6.3 When a discontinuity indication appears on the screen, the maximum attainable indication from the discontinuity shall be adjusted to produce a horizontal reference level trace deflection on the CRT screen. This adjustment shall be made with the calibrated gain control or attenuator, and the instrument reading in decibels shall be recorded on the ultrasonic test report under the heading Indication lever, a .

8.15.6.4 The attenuation factor, c , on the test report is attained by subtracting 1 in. (25 mm) from the sound path distance and multiplying the remainder by 2.

8.15.6.5 The indication rating, d , on the test report is the difference between the reference level and the indication level after the indication level has been corrected by the attenuation factor.

Instruments with gain in dB: $a-b-c = d$

Instruments with attenuation in dB: $b-a-c = d$

8.15.6.6 The length of a discontinuity, as entered under indication length on the test report, shall be determined by locating the points at each end at which the indication amplitude drops 6 dB and measuring between the center lines of those transducer locations.

8.15.6.7 Each weld discontinuity shall be accepted or rejected on the basis of its indication rating and its length in accordance with Table 18. Only those discontinuities which are rejectable need be recorded on the test report.

8.15.7 Each rejectable discontinuity shall be indicated on the weld by a mark directly over the discontinuity for

Table 17
Testing angle

Procedure chart

Material thickness, in.

Weld type	5/16 to 1-1/2	>1-1/2 to 1-3/4	>1-3/4 to 2-1/2	>2-1/2 to 3-1/2	>3-1/2 to 4-1/2	>4-1/2 to 5	>5 to 6-1/2	>6-1/2 to 7	>7 to 8
	*	*	*	*	*	*	*	*	*
Butt	1 0	1 F	1G or 4 F	1G or 5 F	6 or 7 F	8 or 10 F	9 or 11 F	12 or 13 F	12 F
T	1 0	1 F or XF	4 F or XF	5 F or XF	7 F or XF	10 F or XF	11 F or XF	13 F or XF	— —
Corner	1 0	1 F or XF	1G or 4 F or XF	1G or 5 F or XF	6 or 7 F or XF	8 or 10 F or XF	9 or 11 F or XF	13 or 14 F or XF	— —
Electrogas & electroslag	1 0	1 0	1G or 4 1**	1G or 5 P1 or P3	6 or 7 P3	11 or 15 P3	11 or 15 P3	11 or 15 P3	11 or 15 P3

Notes:

- All examinations shall be made from Face A unless otherwise noted on this table.
- All butt welds shall be tested from both sides of the weld from Face A unless otherwise noted on this table.
- All examinations shall be made in Leg I where possible or otherwise specified in this table.
- Examinations in Leg II shall be made only to satisfy provisions of this table, or when necessary, to test weld areas made inaccessible by an unground weld surface or interference with other portions of the weldment.
- A maximum of Leg III shall be used only where thickness or geometry prevents scanning of complete weld areas and heat-affected zone in Leg I or Leg II.
- On tension welds on bridges, the top quarter of thickness must be tested with the final leg of sound progressing from Face B toward Face A. The bottom quarter of thickness must be tested with the final leg of sound progressing from Face A toward Face B; i.e., the top quarter of thickness shall be tested either from Face A in Leg II or from Face B in Leg I at the contractor's option, unless otherwise specified in the contract documents.
- Root areas of single groove weld joints which have backing strips not requiring removal by contract shall be tested in Leg I, and Face A shall be that face opposite the backing strip. (Grinding of the weld face may be necessary to permit complete scanning of the weld and heat-affected zone.)
- Procedure G, 6, 8, 9, 12, 14, or 15 must be followed when testing welds which have been ground flush. The need for grinding may either be to satisfy contract requirements, or to provide a suitable surface for testing from Face A. Face A on both connecting members of butt welds must lie in a single plane.

(See legend and Notes on next page)

102/SPECIFICATION FOR WELDING OF INDUSTRIAL & MILL CRANES

Table 17 (Continued)

Legend:

- X—Check from Face "C."
 G—Grind weld face flush.
 O—Not required.
 A Face—the face of the material from which the initial scanning is done (on T- and corner joints, follow above sketches).
 B Face—opposite the "A" face (same plate).
 C Face—the face opposite the weld on the connecting member of a T- or corner joint.

*Required only where reference level indication of discontinuity is noted in fusion zone while searching at scanning level with primary procedure selected from first column.

**Use 15 or 20 in. screen distance calibration.

No.	Procedure legend		
	Area of weld thickness		
	Top quarter	Middle half	Bottom quarter
1	70°	70°	70°
2	60°	60°	60°
3	45°	45°	45°
4	60°	70°	70°
5	45°	70°	70°
6	70°G A	70°	60°
7	60° B	70°	60°
8	70°G A	60°	60°

its entire length. The depth from the surface and type of discontinuity shall be noted on nearby base metal.

8.15.8 Welds found unacceptable by ultrasonic testing shall be repaired by methods permitted by Section 10 of this specification. Repaired welds shall be retested ultrasonically, and an additional report form completed.

8.15.9 A report form which clearly identifies the work and the area of inspection shall be completed by the ultrasonic inspector at the time of the inspection. The report form for welds that are unacceptable need only contain sufficient information to identify the weld, the inspector (signature), and the acceptability of the weld. An example of such a form is shown in Appendix A.

8.15.10 All report forms pertaining to a weld subject to contractual ultrasonic testing by the manufacturer for the purchaser, including those that show unacceptable quality prior to repair, shall be available for review by the purchaser's representative before the weld is accepted.

P—Pitch and catch shall be conducted for further discontinuity evaluation in only the middle half of the material thickness with only 45 deg or 70 deg transducers of equal specification, both facing the weld. (Transducers preferably held in a fixture to control positioning — see sketch.) Amplitude calibration for pitch and catch is normally made by calibrating a single search unit. When switching to dual search units for pitch and catch inspection, there should be assurance that this calibration does not change as a result of instrument variables.

F—Further evaluate fusion zone in indications with either 70 deg, 60 deg, or 45 deg transducer—whichever sound path is nearest to being perpendicular to the suspected fusion surface.

No.	Procedure legend		
	Area of weld thickness		
	Top quarter	Middle half	Bottom quarter
9	70°G A	60°	45°
10	60° B	60°	60°
11	45° B	70°**	45°
12	70°G A	45°	70°G B
13	45° B	45°	45°
14	70°G A	45°	45°
15	60°G A	70°A B	70°G B

8.15.11 A full set of completed report forms of welds subject to contractual ultrasonic testing by the manufacturer for the purchaser, including any that show unacceptable quality prior to repair, shall be delivered to the purchaser upon completion of the work. The manufacturer's obligation to retain ultrasonic reports shall cease (1) upon delivery of this full set to the purchaser or (2) at the end of one full year after completion of the manufacturer's work, in the event that delivery is not required, or as otherwise provided in the contract.

8.16 Magnetic Particle Examination of Welds

8.16.1 The procedure and technique for magnetic particle examination, when required, shall be in accordance with ASTM E709, *Practice for Magnetic Particle Inspection* (latest edition), and the standards of acceptance shall be in accordance with 8.16.4.

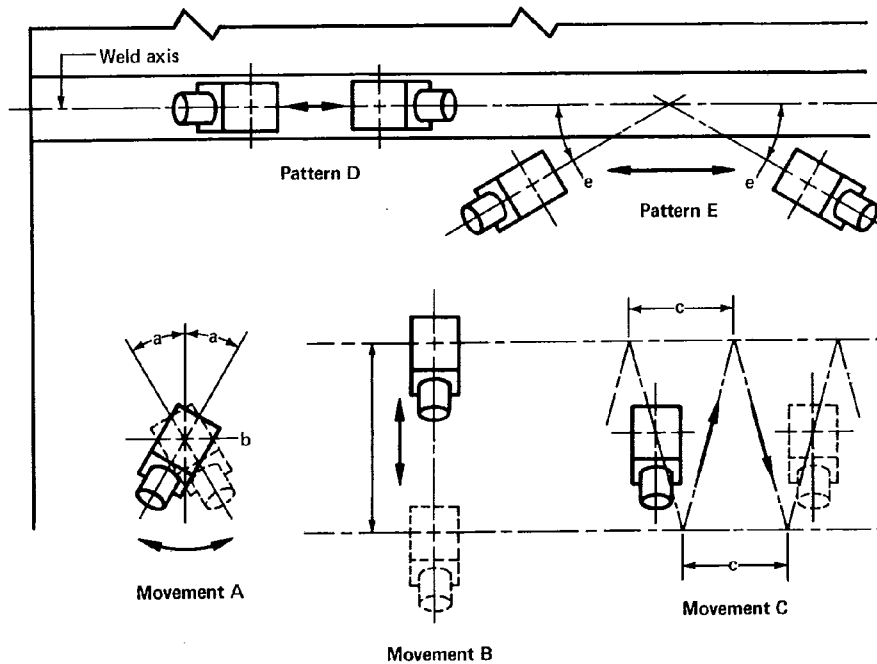

Notes:

1. Testing patterns are all symmetrical around the weld axis with the exception of pattern D which is conducted directly over the weld axis.
2. Testing from both sides of the weld axis is to be made wherever mechanically possible.

Fig. 37—Plan view of welded plate

8.16.2 Variations in testing procedure, equipment, and acceptance standards not included in this specification may be used upon agreement between the manufacturer and the purchaser.

8.16.3 Welds subject to magnetic particle examination shall first be subject to visual examination in accordance with the requirements of 8.6 and 8.7.

8.16.4 Welds that are subject to magnetic particle testing shall be unacceptable if any discontinuities exceed the following limits:

(1) A magnetic particle indication of any porosity or fusion-type discontinuity, that is 1/16 in. (1.6 mm) or larger in greatest dimension, shall not exceed the size, B, indicated in Fig. 35 for the effective throat or weld size involved. The distance from any indication of an acceptable porosity or fusion-type discontinuity to another such discontinuity, to an edge, or to any intersecting weld shall not be less than the minimum clearance, C, indicated by Fig. 35 for the size of discontinuity under exami-

nation. (Appendix C illustrates the application of the requirements given. A sample report form is shown in Appendix A).

(2) Discontinuities meeting the requirements of 8.16.4(1) and having a greatest dimension of less than 1/16 in. (1.6 mm) are nevertheless not acceptable if the sum of their greatest dimensions exceed 3/8 in. (10 mm) in any linear inch (25 mm) of weld.

(3) The limitations given by Fig. 35 for a groove weld effective throat of 1-1/2 in. (38 mm) shall apply to groove welds of greater thickness.

8.17 Liquid Penetrant Examination of Welds

8.17.1 When liquid penetrant examination is required, the procedure and technique shall be in accordance with ASTM E165, *Recommended Practice for Liquid Penetrant Inspection* (latest edition). The standard of acceptance shall be in accordance with 8.17.3.

104/SPECIFICATION FOR WELDING OF INDUSTRIAL & MILL CRANES

Table 18
Ultrasonic acceptance-rejection criteria

Weld thickness and search unit angle											
Flaw	5/16 to 3/4	>3/4 to 1-1/2	> 1-1/2 to 2-1/2			>2-1/2 to 4			>4 to 8		
	70°	70°	70°	69°	45°	70°	60°	45°	70°	60°	45°
Class A	+10 & lower	+8 & lower	+4 & lower	+7 & lower	+9 & lower	+1 & lower	+4 & lower	+6 & lower	-2 & lower	+1 & lower	+3 & lower
Class B	+11	+9	+5 +6	+8 +9	+10 +11	+2 +3	+5 +6	+7 +8	-1 0	+2 +3	+4 +5
Class C	+12	+10	+7 +8	+10 +11	+12 +13	+4 +5	+7 +8	+9 +10	+1 +2	+4 +5	+6 +7
Class D	+13 & up	+11 & up	+9 & up	+12 & up	+14 & up	+6 & up	+9 & up	+11 & up	+3 & up	+6 & up	+8 & up

Notes:

- Class B and C flaws shall be separated by at least 2L, L being the length of the longer flaw, except that when two or more such flaws are not separated by at least 2L, but the combined length of flaws and their separation distance is equal to or less than the maximum allowable length under the provisions of Class B or C, the flaw shall be considered a single acceptable flaw.
- Class B and C flaws shall not begin at a distance less than 2L from the end of the weld, L being the flaw length.
- Flaws detected at "scanning level" in the root face area of complete penetration double groove weld joints shall be evaluated using an indication rating 4 dB more sensitive than that described in 6.19.6.5 when such welds are designated as "tension welds" on the drawing (subtract 4 dB from the indication rating "d").

Class A (large flaws)

Any indication in this category shall be rejected (regardless of length).

Class B (medium flaws)

Any indication in this category having a length greater than 3/4 in. (19 mm) shall be rejected.

Class C (small flaws)

Any indication in this category having a length greater than 2 in. (51 mm) in the middle half or 3/4 in. (19 mm) length in the top or bottom quarter of weld thickness shall be rejected.

Class D (minor flaws)

Any indication in this category shall be accepted regardless of length or location in the weld.

8.17.2 Variations in testing procedure, equipment, and acceptance standards not included in this specification may be used upon agreement between the manufacturer and purchaser.

8.17.3 Welds that are subject to liquid penetrant examination shall be evaluated on the basis of the requirements for visual inspection as defined in 8.6 and 8.7.

8.18 Inspection of Studs

8.18.1 Welded studs that do not show a full 360 degree weld fillet during visual inspection and any stud that has

been repaired by welding shall be bent to an angle of 15 degrees from its original axis with hammer blows. For studs showing less than 360 degrees weld fillet, the direction of bending shall be opposite to the missing weld fillet. Studs that crack in the weld, the base metal, or the shank during inspection or subsequent straightening shall be replaced.

8.18.2 At least 1 stud in every 100 shall be bent to an angle of 15 degrees from its original axis with hammer blows. Alternatively threaded studs may be tested with

Scanning levels

Sound path (in.)*	Above zero reference, dB
to 2-1/2 (64 mm)	20
>2-1/2 to 5 (64-127 mm)	25
>5-10 (127-254 mm)	35
>10-15 (254-381 mm)	45

*This column refers to sound path distance; NOTE material thickness.

a calibrated torque wrench to the torque shown in Fig. 38 for the diameter and thread of the stud in a device similar to that shown. If the stud fails, the procedure shall be checked in accordance with 6.5 and two more of the existing studs shall be tested. If either of these two studs fail, all of the studs represented by the tests shall be tested or rejected.

8.18.3 The inspector, where conditions warrant, may select a reasonable number of additional studs to be subjected to the tests specified in 8.18.1 and 8.18.2. These additional stud tests may be considered by the manufacturer to be special tests.

9. Field Weld Repair and Modification

9.1 General. This section is a guide to aid the manufacturer and the purchaser by suggesting pertinent items that should be considered at the time of initial contract negotiations. The eventual need for field weld repairs as a result of normal wear and tear, modification, or accident is often forgotten. Every repair, no matter how small, becomes the total responsibility of the purchaser and the organization performing the repair work, who must consider its effect on the equipment involved. The original manufacturer should be contacted to insure that the projected repair is advisable and sound from an engineering standpoint. Safe recommended repairs can only be accomplished with the knowledge of the design loading on the equipment and the critical area.

9.2 Field Repair-Manufacturer's Responsibility. The manufacturer shall furnish, as a part of instruction manuals or as a separate publication, instructions for field repair when required by the contract. The completeness and extent of material identification and welding repair procedures should be thoroughly covered in the contract.

9.2.1 Instructions by the manufacturer should include the following:

- (1) Qualification requirements of the welder performing the repair (see Section 7 for minimum requirement).
- (2) A list of materials used in the manufacture of the equipment and the location of materials by some appropriate means such as an outline drawing. This shall include lists and locations of those materials that (a) are easily weldable without preheat or postheat treatment, provided ambient temperatures are considered normal, and (b) require special welding procedures. For special welding procedures, the manufacturer shall include info concerning the base metals, filler metals, and preheat or postheat treatment so that properly qualified welders can make an acceptable weld repair.

9.2.2 All field weld repair procedures shall include recommended means for inspection or testing of the repair by a competent engineer or the equipment manufacturer and necessary nondestructive testing procedures.

9.2.3 The manufacturers shall list special precautions for field welding their products and other necessary precautions, such as

Field repair shall not proceed (1) without adequate preparation (thorough cleaning and joint preparation) and a full review of any previous repairs in the area involved), (2) until the welder and weld repair area are adequately protected from the elements, and a proper equipment environment is provided, or (3) without considering the stresses on the members. A method by which stresses can be relieved before welding, as well as the sequence of repair, shall be considered. The manufacturer must indicate weldments and components on which field repairs are not recommended.

9.2.4 Safety precautions and good workmanship instructions listed in the various ANSI and AWS specifications shall be followed, including ANSI Z49.1, *Safety in Welding and Cutting*.

9.3 Field Repair — Purchaser's Responsibility

9.3.1 The purchaser shall appoint a competent person who shall be responsible for the actual field execution of the repair work, and the complete detailed adherence to the repair procedures furnished by the manufacturer.

9.3.2 Purchasers or their agents shall permit only qualified and properly trained personnel to perform field weld repairs, such as welders qualified in accordance with this specification.

9.3.3 Full and complete records of all repaired welds shall be maintained by means of marked outline drawings or other appropriate documents.

10. Repair and Correction of Discontinuities

10.1 Weld Repairs

10.1.1 Overlap or Excessive Convexity. Remove excess weld metal.

10.1.2 Excessive Concavity of Weld or Crater and Undersize Welds. Prepare surfaces and deposit additional weld metal. All slag shall be removed and the adjacent base metal shall be clean before additional welding.

10.1.3 Cracks in Weld or Base Metal. Determine the extent of the crack by dye penetrant, magnetic particle inspection, or other suitable means. Remove the crack and adjacent sound metal for a 2 in. (51 mm) length beyond each end of the crack, and then reweld.

106/SPECIFICATION FOR WELDING OF INDUSTRIAL & MILL CRANES

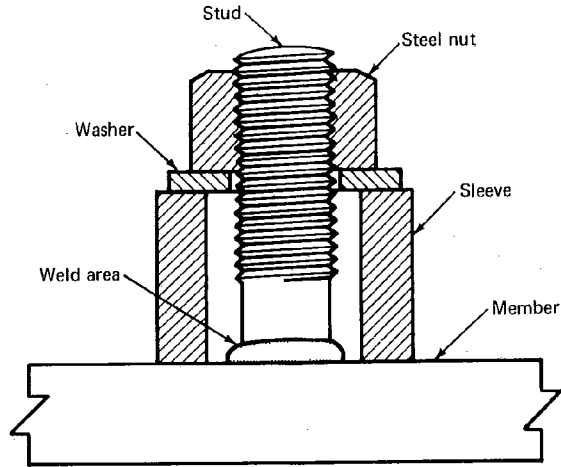

Note: The dimensions are appropriate to the size of the stud. The threads of the stud shall be clean and free of lubricant other than the residue of cutting oil.

Required torque for testing threaded studs				
Nominal diameter of studs		Threads per inch & series designated	Testing torque	
in.	mm		ft-lb	J
1/4	6.4	28 UNF	5.0	6.8
1/4		20 UNC	4.2	5.7
5/16	7.9	24 UNF	9.5	12.9
5/16		18 UNC	8.6	11.7
3/8	9.5	24 UNF	17.0	23.0
3/8		16 UNC	15.0	20.3
7/16	11.1	20 UNF	27.0	36.6
7/16		14 UNC	24.0	32.5
1/2	12.7	20 UNF	42.0	57.0
1/2		13 UNC	37.0	50.2
9/16	14.3	18 UNF	60.0	81.4
9/16		12 UNC	54.0	73.2
5/8	15.9	18 UNF	84.0	114.0
5/8		11 UNC	74.0	100.0
3/4	19.0	16 UNF	147.0	200.0
3/4		10 UNC	132.0	180.0
7/8	22.2	14 UNF	234.0	320.0
7/8		9 UNC	212.0	285.0
1.0	25.4	12 UNF	348.0	470.0
1.0		8 UNC	318.0	430.0

Fig. 38—Torque testing arrangement and table of testing torques

Prior to rewelding, these areas shall be checked by an appropriate inspection method, such as magnetic particle or dye penetrant, to insure complete removal of cracked material.

10.1.4 Undercutting. Undercutting may be repaired by grinding and blending or by welding. It is preferably done by careful grinding and blending. Grinding should be performed with a pencil type grinder. The grinding marks should be transverse to the length of the weld, and have a 250×10^{-6} in. (6.3×10^{-6} m) finish or better. Blending shall be done with a slope not to exceed 1 in 3. On plates of 1/2 in. (13 mm) thickness and above, up to 7 percent reduction of base material thickness is permitted. Repair of undercut areas by grinding and blending in excess of this amount may be permitted with the approval of the design engineer. When undercut is to be repaired by welding, prepare the surfaces and then deposit additional weld metal.

10.2 Base Metal Repairs

10.2.1 Defects in Edges of Plate. If a defect is found in a plate edge that exceeds the limits imposed in Table 6, it shall be removed and repaired in accordance with 5.3.

10.2.2 Arc Strikes and Temporary Attachment Areas. Arc strikes or severed temporary welds in critical locations, as defined by the design engineer, must be ground smooth to insure that no abrupt change in section exists. The smoothed area shall be inspected by an appropriate nondestructive testing method to insure that there are no existing cracks or similar discontinuities. Any cracks or similar discontinuities must be repaired in accordance with 10.1.3.

10.3 Removal of Defective Areas. The removal of weld metal or portions of the base metal may be done by machining, grinding, chipping, oxygen gouging, or air carbon arc gouging. It shall be done in such a manner that the remaining weld metal or base metal is not nicked or undercut. Oxygen gouging shall not be used on quenched-and-tempered steel. Unacceptable portions of the weld shall be removed without substantial removal of the base metal. Additional weld metal, to compensate for any deficiency in size, shall be deposited using low-hydrogen electrodes, preferably smaller in diameter than

those used for making the original weld, and preferably not more than 5/32 in. (4 mm) in diameter. The surfaces shall be cleaned thoroughly before welding. Defects that occur in material handling that do not affect the structural integrity of the design can be repaired by grinding.

10.4 Distortion and Camber. Members distorted by welding shall be straightened by mechanical means or by carefully supervised application of a limited amount of localized heat. The temperature of heated areas, as measured by approved methods, shall be limited to that imposed by the materials exposed to the heat, but it shall not exceed 1100° F (590° C) for quenched-and-tempered steel, nor 1600° F (890° C) for other steels. The part to be heated for straightening shall be substantially free of stress and external forces, except those stresses resulting from the mechanical straightening method used in conjunction with the application of heat.

10.5 Correction of Improperly Fitted and Welded Members. If a weld is found to be unacceptable after additional work has rendered it inaccessible, or new conditions make correction of the unacceptable weld dangerous or ineffectual, the original conditions shall be restored by removing welds or members, or both, before the corrections are made. If this is not done, the deficiency shall be compensated for by additional work performed according to an approved revised design. Improperly fitted and welded members require design engineer approval prior to cutting apart. Cutting is to be handled by methods similar to those in 10.3.

10.6 Repair of Studs

10.6.1 Stud welds that do not have a full 360 degree weld flash may be repaired by adding a 3/16 in. (5 mm) fillet weld in place of the missing flash. A low-hydrogen welding process shall be used in accordance with requirements of this specification.

10.6.2 On all components subject to tensile stresses, the area where a defective stud has been removed shall be made smooth and flush. Where base metal has been pulled out in the course of stud removal, a low-hydrogen welding process shall be used to fill the pockets in accordance with the requirements of this specification, and the weld surface shall be ground flush.

Appendix A Suggested Forms

WELDING PROCEDURE QUALIFICATION TEST RECORD

PROCEDURE SPECIFICATION

Material specification _____
 Welding process _____
 Manual or machine _____
 Position of welding _____
 Filler metal specificatin _____
 Filler metal classification _____
 Weld metal grade* _____
 Shielding gas _____ Flow rate _____
 Single or multiple pass _____
 Single or multiple arc _____
 Welding current _____
 Welding progression _____
 Preheat temperature _____
 Postheat treatment _____
 Welder's name _____

*Applicable when filler metal has no
 AWS classification.

GROOVE WELD TEST RESULTS

Tensile strength, psi
 1. _____
 2. _____

Guided-bend tests (2 root-, 2 face-, or 4 side-bend)

Root	Face
1. _____	1. _____
2. _____	2. _____

Radiographic-ultrasonic examination

FILLET WELD TEST RESULTS

Minimum size multiple pass	Maximum size single pass
Macroetch	Macroetch
1. _____ 3. _____	1. _____ 3. _____
2. _____	2. _____

All-weld-metal tension test

Tensile strength; psi _____
 Yield point/strength, psi _____
 Elongation in 2 in., % _____
 Laboratory test no. _____

WELDING PROCEDURE

Pass no.	Electrode size	Welding current		Speed of travel	Joint detail
		Amperes	Volts		

We, the undersigned, certify that the statements in this record are correct and that the test welds were prepared, welded, and tested in accordance with the requirements of AWS Specification D14.1.

Procedure no. _____ Manufacturer or contractor _____

Revision no. _____ Authorized by _____

Form E-2

Date _____

© 1978 by American Welding Society. All rights reserved

110/SUGGESTED FORMS

**WELDING PROCEDURE QUALIFICATION TEST RECORD
FOR ELECTROSLAG AND ELECTROGAS WELDING**

PROCEDURE SPECIFICATION

Material specification _____
 Welding process _____
 Position of welding _____
 Filler metal specification _____
 Filler metal classification _____
 Filler metal _____
 Flux _____
 Shielding gas _____ Flow rate _____
 Gas dew point _____
 Thickness range this test qualifies _____
 Single or multiple pass _____
 Single or multiple arc _____
 Welding current _____
 Preheat temperature _____
 Postheat temperature _____
 Welder's name _____

TEST RESULTS

Reduced-section tensile test

Tensile strength, psi
 1. _____
 2. _____

All-weld-metal tension test

Tensile strength, psi _____
 Yield point/strength, psi _____
 Elongation in 2 in., % _____

Side-bend tests

1. _____ 3. _____
 2. _____ 4. _____

Radiographic-ultrasonic examination _____

Impact tests

Size of specimen _____ Test temp _____
 Ft•lb: 1. _____ 2. _____ 3. _____ Avg. _____
 High _____ Low _____
 Laboratory test no. _____

WELDING PROCEDURE

Pass no.	Electrode size	Welding current		Joint detail
		Amperes	Volts	
Guide tube flux _____ Guide tube composition _____ Guide tube diameter _____ Vertical rise speed _____ Traverse length _____ Traverse speed _____ Dwell _____ Type of molding shoe _____				

We, the undersigned certify that the statements in this record are correct and that the test welds were prepared, welded, and tested in accordance with the requirements of AWS Specification D14.1.

Procedure no. _____
 Revision no. _____
 Form E-3

Manufacturer or contractor _____
 Authorized by _____
 Date _____
 © 1978 by American Welding Society. All rights reserved.

WELDER AND WELDING OPERATOR QUALIFICATION TEST RECORD

Welder or welding operator's name _____ Identification no. _____
 Welding process _____ Manual _____ Semiautomatic _____ Machine _____
 Position _____
 (Flat, horizontal, overhead or vertical — if vertical, state whether upward or downward)
 In accordance with procedure specification no _____
 Material specification _____
 Diameter and wall thickness (if pipe) — otherwise, joint thickness _____
 Thickness range this qualifies _____

FILLER METAL

Specification no. _____ Classification _____ F no. _____
 Describe filler metal (if not covered by AWS specification) _____

 Is backing strip used? _____
 Filler metal diameter and trade name _____ Flux for submerged arc or gas for gas metal arc or flux
 cored arc welding _____

VISUAL INSPECTION (9.25.1)

Appearance _____ Undercut _____ Piping porosity _____

Guided Bent Test Results

Type	Result	Type	Result

Test conducted by _____ Laboratory test no. _____
 per _____ Test date _____

Fillet Test Results

Appearance _____ Fillet size _____
 Fracture test root penetration _____ Marcoetch _____
 (Describe the location, nature, and size of any crack or tearing of the specimen.)
 Test conducted by _____ Laboratory test no. _____
 per _____ Test date _____

RADIOGRAPHIC TEST RESULTS

Film identification	Results	Remarks	Film identification	Results	Results

Test witnessed by _____ Test no. _____
 per _____

We, the undersigned certify that the statements in this record are correct and that the test welds were prepared, welded, and tested in accordance with the requirements of AWS Specification D14.1.

Manufacturer or contractor _____
 Authorized by _____
 Date _____

112/SUGGESTED FORMS

TACK WELDER QUALIFICATION TEST RECORD

Tack Welder's Name _____ Identification no. _____

Welding process _____

Position _____

(Flat, horizontal, overhead or vertical—If vertical, state whether upward or downward)

In accordance with procedure specification no. _____

Material specification _____

Diameter and wall thickness (if pipe)—otherwise, joint thickness _____

Filler Metal

Specification no. _____ Classification _____ F no. _____

Describe filler metal (if not covered by AWS specification) _____

For Information Only

Filler metal diameter and trade name _____ Flux for submerged arc or gas for gas metal arc or flux cored arc welding _____

Test Results

Appearance _____ Fillet size _____

Fracture test root penetration _____ Soundness _____

(Describe the location, nature, and size of any crack or tearing of the specimen.)

Test conducted by _____ Laboratory test no. _____
per _____

We the undersigned, certify that the statements in this record are correct and tested in accordance with the requirement of AWS Specification D14.1.

Manufacturer or contractor _____

Authorized by _____

Date _____

Form E-5

© 1978 by American Welding Society. All rights reserved.

REPORT OF ULTRASONIC TESTING OF WELDS

Project _____ Report no. _____

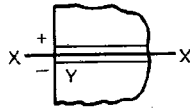

Weld identification _____
 Material thickness _____
 Weld joint AWS _____
 Welding process _____
 Quality requirements — section no. _____
 Remarks _____

Line number	Indication number	Transducer angle	From Face	Leg*	Decibels				Discontinuity				Discontinuity elevation	Remarks	
					Indication level	Reference level	Attenuation factor	Indication rating	Length	Angular distance (sound path)	Depth from "A" surface	Distance			
												From X			From Y
a	b	c	d												
1															
2															
3															
4															
5															
6															
7															
8															
9															
10															
11															
12															
13															
14															
15															
16															
17															
18															
19															
20															
21															
22															
23															
24															
25															
26															

We, the undersigned, certify that the statements in this record are correct and that the welds were prepared and tested in accordance with the requirements of AWS Specification D14.1.

Test date _____ Manufacturer or contractor _____

Inspected by _____ Authorized by _____

Date _____

© 1978 by American Welding Society. All rights reserved

Form E-6

(Continued)

114/SUGGESTED FORMS

Notes:

1. In order to attain Rating "d"
 - (A) With instruments with gain control, use the formula $a - b - c = d$.
 - (B) With instruments with attenuation control, use the formula $b - a - c = d$.
 - (C) A plus or minus sign must accompany the "d" figure unless "d" is equal to zero.
2. Distance from X is used in describing the location of a weld discontinuity in a direction perpendicular to the weld reference line. Unless this figure is zero, a plus or minus sign must accompany it.
3. Distance from Y is used in describing the location of a weld discontinuity in a direction parallel to the weld reference line. This figure is attained by measuring the distance from the "Y" end of the weld to the beginning of said discontinuity.
4. Evaluation of Retested Repaired Weld Areas must be tabulated on a new line on the report form. If the original report form is used, R_n shall prefix the indication number. If additional forms are used, the R number shall prefix the report number.

DYE PENETRANT INSPECTION REPORT

Customer _____ Date _____
 Order No. _____ Material _____
 Dwg. No. _____ Specification _____
 For _____

Pieces	Description	Comments

Soak Time _____

The above parts have been carefully tested with dye penetrant. This inspection is limited to defects of the type which can normally be located with the dye penetrant inspection method.

Appendix B Commonly Used Metric Conversions

Inch-millimeter conversion

1 in. = 25.4 mm exactly

To convert inches to millimeters, multiply the inch value by 25.4.

To convert millimeters to inches, divide the millimeter value by 25.4.

Inch and millimeter decimal equivalents of fractions of an inch

Inch			Inch		
Fraction	Decimal	Millimeter	Fraction	Decimal	Millimeter
1/64	0.015 625	0.396 875	33/64	0.515 625	13.096 875
1/32	0.031 250	0.793 750	17/32	0.531 250	13.493 750
3/64	0.046 875	1.190 625	35/64	0.546 875	13.890 625
1/16	0.062 500	1.587 500	9/16	0.562 500	14.287 500
5/64	0.078 125	1.984 375	37/64	0.578 125	14.684 375
3/32	0.093 750	2.381 250	19/32	0.593 750	15.081 250
7/64	0.109 375	2.778 125	39/64	0.609 375	15.478 125
1/8	0.125 000	3.175 000	5/8	0.625 000	15.875 000
9/64	0.140 625	3.571 875	41/64	0.640 625	16.271 875
5/32	0.156 250	3.968 750	21/32	0.656 250	16.668 750
11/64	0.171 875	4.365 625	43/64	0.671 875	17.065 625
3/16	0.187 500	4.762 500	11/16	0.687 500	17.462 500
13/64	0.203 125	5.159 375	45/64	0.703 125	17.859 375
7/32	0.218 750	5.556 250	23/32	0.718 750	18.256 250
15/64	0.234 375	5.953 125	47/64	0.734 375	18.653 125
1/4	0.250 000	6.350 000	3/4	0.750 000	19.050 000
17/64	0.265 625	6.746 875	49/64	0.765 625	19.446 875
9/32	0.281 250	7.143 750	25/32	0.781 250	19.843 750
19/64	0.296 875	7.540 625	51/64	0.796 875	20.240 625
5/16	0.312 500	7.937 500	13/16	0.812 500	20.637 500
21/64	0.328 125	8.334 375	53/64	0.828 125	21.034 375
11/32	0.343 750	8.731 250	27/32	0.843 750	21.431 250
23/64	0.359 375	9.128 125	55/64	0.859 375	21.828 125
3/8	0.375 000	9.525 000	7/8	0.875 000	22.225 000
25/64	0.390 625	9.921 875	57/64	0.890 625	22.621 875
13/32	0.406 250	10.318 750	29/32	0.906 250	23.018 750
27/64	0.421 875	10.715 625	59/64	0.921 875	23.415 625
7/16	0.437 500	11.112 500	15/16	0.937 500	23.812 500
29/64	0.453 125	11.509 375	61/64	0.953 125	24.209 375
15/32	0.468 750	11.906 250	31/32	0.968 750	24.606 250
31/64	0.484 375	12.303 125	63/64	0.984 375	25.003 125
1/2	0.500 000	12.700 000	1	1.000 000	25.400 000

Appendix C Examples of Weld Quality Requirements

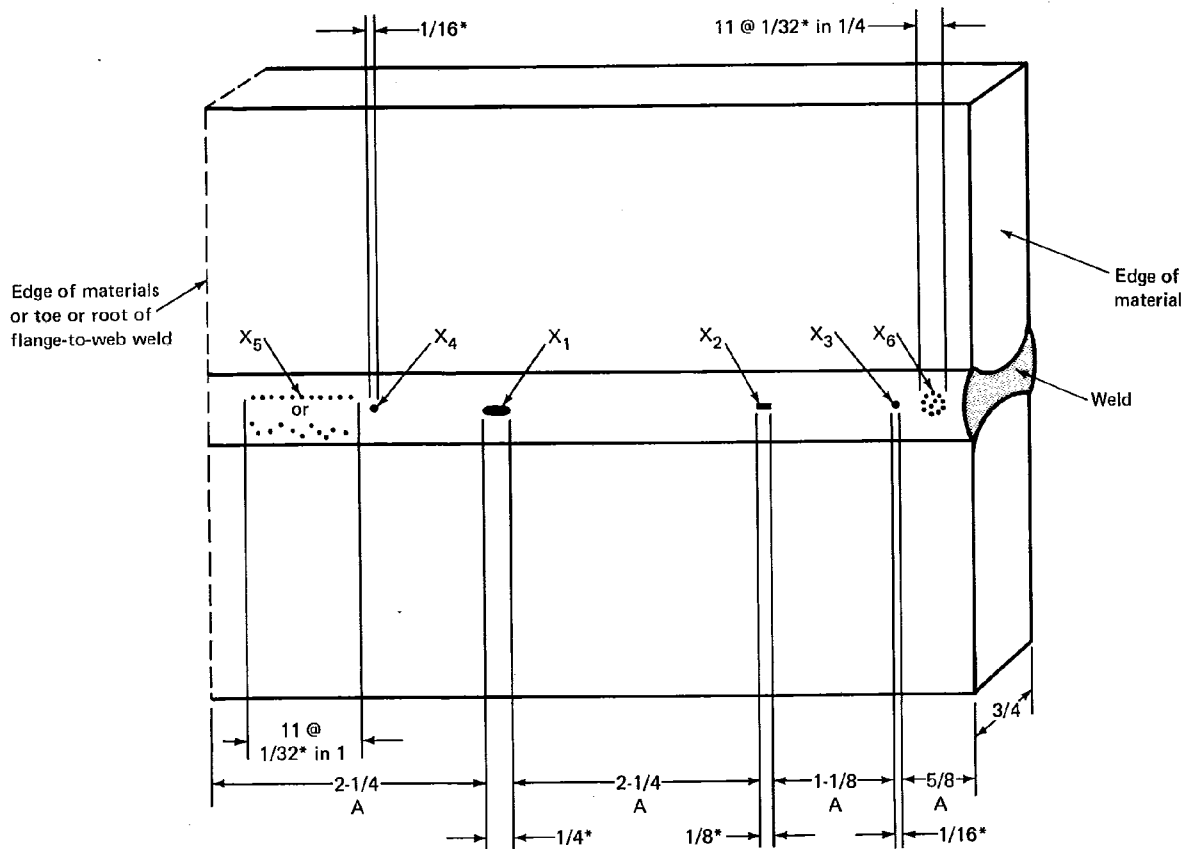

Notes:

1. A — minimum clearance allowed between edges of porosity or fusion-type discontinuities 1/16 in. (1.6 mm) or larger. Larger of adjacent discontinuities governs.
2. X₁ — largest permissible porosity or fusion-type discontinuity for 3/4 in. (19.0 mm) joint thickness
3. X₂, X₃, X₄ — porosity or fusion-type discontinuity 1/16 in. (1.6 mm) or larger, but less than maximum permissible for 3/4 in. (19.0 mm) joint thickness.
4. X₅, X₆ — porosity or fusion-type discontinuity less than 1/16 in.

Interpretation:

1. Porosity or fusion-type discontinuity X₄ is not acceptable because it is within the minimum clearance allowed between edges of such discontinuities
2. Remainder of weld is acceptable.

*Defect size indicated is assumed to be its greatest dimension.